

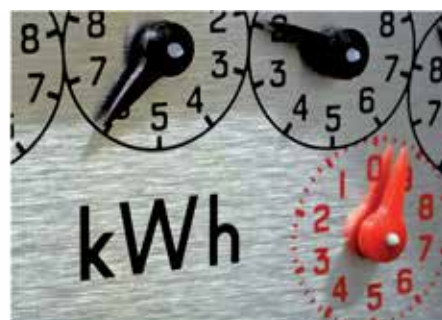

EMERSON[™]
Industrial Automation



DYNEO[®] VARIABLE SPEED DRIVES
Unidrive M variable speed drives
LSRPM permanent magnet synchronous motors

0.75 to 85 kW

Technical catalogue

5034 en - 2013.09/b



Unidrive M range



0.75 kW to 90 kW
100 | 200 | 400 | 575 | 690 Vac

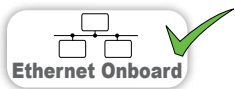

Unidrive M Drive Modules for applications up to 90 kW*



The Unidrive M drive module range is specifically designed for demanding industrial applications, providing exceptional levels of functionality, flexibility and performance.

The motor control algorithm in Unidrive M drives has been qualified with Dyneo® motors to ensure optimal performance.



Unidrive M drive modules are designed for easy integration into cabinets.

*1.2 MW from mid 2014



For more Unidrive M information



0.75 kW to 400 kW

Innovation you can place your trust in

Alliance of magnet rotor technology and the asynchronous motor's tried and tested mechanism

Exceptional savings

On the purchase price

- Reduction in the weight and dimensions of the driven machine: up to 3 frame sizes smaller
- Simplification through elimination of transmission devices (pulleys, belts, etc)
- Longer service life: Lower bearing temperature, etc

On energy bills: High efficiency over the entire speed range

On maintenance: Less stress on the mechanism

ENERGY SAVINGS

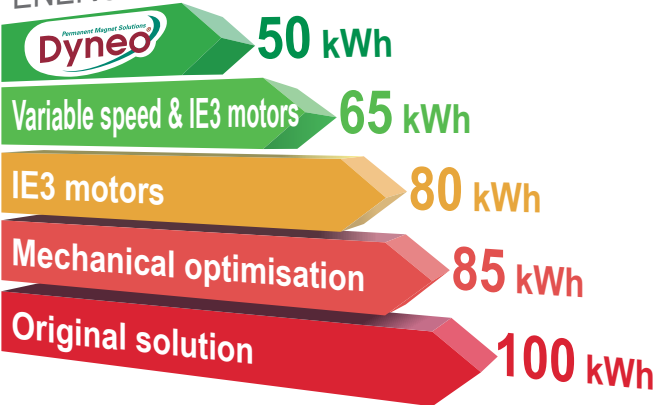

Performance

- Constant torque over the entire speed range
- Optimised power with centrifugal torque operation

Modularity

- Adapt to any application when used in combination with a 3000 range geared motor



Guaranteed Availability !

DELIVERY TIMES EX-WORKS: 5, 10 or 15 working days on a selection of drive systems

Innovative solutions

DYNEO® offers innovative, high-performance solutions consisting of permanent magnet synchronous motors used in conjunction with Control Techniques variable speed drives.

Combined with the **UNIDRIVE M** drive, the innovative **LSRPM** permanent magnet synchronous motor technology is revolutionising the electric motor by offering solutions adapted to the industrial environment, and produces optimum electrical and mechanical performance:

- extended speed range
- high torque
- very high efficiency
- compact design

The **UNIDRIVE M - LSRPM** combinations described in this manual are suitable for most applications: ventilation, pumping, compression, materials handling, conveying, centrifuging, extrusion, etc.

3000 range geared motors are used to adapt the typical motor characteristics (torque/speed) to that of the driven machine, while taking account of the need for adaptability and performance.

Add-ons or options for drives and motors can be included to satisfy the particular demands of the process.

For further information about the products described in this manual, please consult the corresponding technical documentation.



Contents

INTRODUCTION

Modular offer	6-7
Unidrive M drive	8
LSRPM motors	9
3000 range gearboxes combined with the LSRPM and Unidrive M	10
Variable speed drive designation	11
Selection method	12

PERFORMANCE

Efficiency	13
5500 range - 0 to 5500 min ⁻¹ Torque from 0 to 147 N.m	14
4500 range - 0 to 4500 min ⁻¹ Torque from 0 to 170 N.m	15
3600 range - 0 to 3600 min ⁻¹ Torque from 0 to 225 N.m	16
3000 range - 0 to 3000 min ⁻¹ Torque from 0 to 271 N.m	17
2400 range - 0 to 2400 min ⁻¹ Torque from 0 to 320 N.m	18
1800 range - 0 to 1800 min ⁻¹ Torque from 0 to 450 N.m	19
1500 range - 0 to 1500 min ⁻¹ Torque from 0 to 550 N.m	20-21
900 range - 0 to 900 min ⁻¹ Torque from 0 to 900 N.m	22-23
750 range - 0 to 750 min ⁻¹ Torque from 0 to 1100 N.m	24-25

SELECTION

5500 range	26
4500 range	27
3600 range	28
3000 range	29
2400 range	30
1800 range	31
1500 range	32
900 range	33
750 range	34

INSTALLATION AND OPTIONS

General information	36
Installation	37-38
Reinforced insulation	39
Selection of position sensor	40
Encoders	41
Forced ventilation - Cable glands	42
Thermal protection	43

DRIVE DIMENSIONS

Unidrive M	44
------------------	----

MOTOR DIMENSIONS

Shaft extensions	45
Foot mounted IM B3	46
Foot and flange mounted IM B35	47
Flange mounted IM B5 - IM V1	48
Foot and face mounted IM B34	49
Face mounted IM B14	50
Motor with options	51

MOTOR CONSTRUCTION

Definition of "Index of Protection" (IP/IK)	52
External finishing	53
Mounting arrangements	54
Bearings and lubrication	55
Connection	56
Motor vibration levels	57

GENERAL INFORMATION

Quality commitment	58
Standards and approvals	59-60
Nameplates	61
Configurator	62

Modular offer

Control Mode

CB 3000

Mub 3000

Ot 3000

LSRPM

LSRPM With encoder

- Open loop vector or V/Hz induction motor* control
- Open loop Rotor Flux Control for induction motors* (RFC-A)
- Closed loop Rotor Flux Control for induction motors* (RFC-A) (with SI-Encoder)
- Open loop permanent magnet motor* control (RFC-S)
- Closed loop permanent magnet motor* control (RFC-S) (with SI-Encoder)

Active Front End (AFE)
power quality converter

* Control of motors and geared motors

Optional Drive Programming and Operator Interface

Unidrive M Connect

KI-Keypad

KI-Keypad RTC

Remote Keypad

Operator Interface

Smartcard

SD Card

Centralized PLC/ Motion Control

Motion Controller

PLC

Industrial Computer

Optional Input/Output

Remote I/O

SI-I/O

Standard

- 5 x Analog I/O
- 8 x Digital I/O (including 2 x high speed I/O [250 µs])
- 1 x STO



Modular offer



Applications with PLC or Motion Functionality

Standard

Easy to use onboard PLC and advanced motion control using industry standard CoDeSys programming environment



SI-Applications Plus compatible module which allows existing SyPTPro application programs to be re-compiled for Unidrive M700



MCI200 Advanced machine control using industry standard CoDeSys programming environment for Unidrive M700 and M800



MCI210 Extended advanced machine control using industry standard CoDeSys programming environment with simultaneous connectivity to 2 separate Ethernet networks for Unidrive M700 and M800



Communications

Standard

RS 485 (Modbus RTU)



SI-EtherCAT



SI-PROFIBUS



SI-Ethernet



SI-DeviceNet



SI-CANopen



Feedback

SI-Encoder



Safety

SI-Safety



DC backup power supply

24 - 1067 VDC power



24 V control

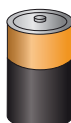

Unidrive M drive

The Unidrive M is a universal drive, designed for controlling asynchronous, servo or synchronous motors such as LSRPM.

This feature gives the Unidrive M a vast field of applications, and it has therefore been endowed with a level of performance and functionality to cope with the most demanding systems.

Heavy duty or normal duty:

The Unidrive M continuous output current and maximum transient current depend on the operating conditions.

Heavy duty:

To obtain the maximum transient overload current available (applications at constant torque, or at rated torque required at low speed), the continuous output current (I_{co}) is limited.

Normal duty:

If the operating conditions are not very demanding (for example, centrifugal applications: fans, pumps, etc), the output current can be increased and a motor with a higher output power can be controlled. However, the maximum transient current is limited.



Output selection tables at 40°C - Control mode RFC-S

Drive type	Normal duty				Heavy duty			
	Continuous current (A)			Peak current (A)	Continuous current (A)			RFC peak current (A)
	3 kHz	4 kHz	6 kHz		3 kHz	4 kHz	6 kHz	
Unidrive M 600/700/800								
034 00025		3.4		3.7		2.5		5
034 00031		4.5		4.9		3.1		6.2
034 00045		6.2		6.8		4.5		9
034 00062		7.7		8.4		6.2		12.4
034 00078		10.4		11.4		7.8		15.6
034 00100		12.3		13.5	10		9.2	20
044 00150		18.5		20.3		15		30
044 00172	24		21.8	26.4	17.2		16.1	34.4
054 00270	30		25.8	33.0	25.4	23.7	20.3	54
054 00300	31		30.7	34.1	30	29.7	24	66
064 00350		38		41.8		35		70
064 00420		48		52.8	42		35.0	84
064 00470	63.0	57.0	48	69.3	46	42	35.0	94
074 00660		79		86.9		66	57	132
074 00770		94		103.4	77	70	59	154
074 01000	112		95	123.2	100	88	73	200
084 01340		155		170.5	134	130	109	268
084 01570	184		169	202.4	157	143	121	314

LSRPM motors



The motor rotor contains a powerful magnetic field. When the rotor is separated from the motor, its field may affect pacemakers or disturb digital devices such as watches, mobile phones, etc.

Assembly or maintenance of the rotor must not be carried out by people with a pacemaker or any other implanted medical electronic device.

The assembled motor presents no risk.



Description of motors

Description	Materials	Comments
Frame	LSRPM: Aluminium alloy	<ul style="list-style-type: none"> - With integral or screw-on feet, or without feet - 4 or 6 fixing holes for housings with feet - Lifting rings - Earth terminal with an optional jumper screw
Stator	Insulated low-carbon magnetic steel laminations Electroplated copper	<ul style="list-style-type: none"> - Low carbon content guarantees long-term lamination pack stability - Welded laminations - Optimised magnetic circuit - Insulation or coating system making it possible to withstand the sudden voltage variations caused by the high switching frequencies of IGBT transistor drives in accordance with IEC 60034-17 - Class F insulation - Thermal protection provided by PTC probes (1 per phase, 2-wire output)
Rotor	Insulated low-carbon magnetic steel laminations Aluminium alloy Nd-Fe-B magnet	<ul style="list-style-type: none"> - Magnet fixing system. LS patented - Dynamically balanced rotor: <ul style="list-style-type: none"> • level A for speeds $\leq 3000 \text{ min}^{-1}$ • level B for speeds $> 3000 \text{ min}^{-1}$
Shaft	Steel	
End shields	Cast iron	
Bearings and lubrication		<ul style="list-style-type: none"> - Ball bearings, C3 play - Preloaded NDE bearings - Greased for life up to frame size 225 - Open type, regreasable for frame size 250 upwards - Insulated bearings depending on the range
Labyrinth seal Lipseals	Plastic or steel Synthetic rubber	<ul style="list-style-type: none"> - Lipseal or deflector at drive end for all flange mounted motors - Lipseal, deflector or labyrinth seal for foot mounted motors
Fan	Composite material or aluminium alloy or steel	- Bi-directional
Fan cover	Pressed steel	- Fitted, on request, with a drip cover for operation in vertical position, shaft end facing down
Terminal box	Aluminium alloy	<ul style="list-style-type: none"> - Fitted with a terminal block with 3 or 6 steel terminals as standard (brass as an option) - Pre-drilled terminal box without cable glands - 1 earth terminal in each terminal box
Brake motor		FCR: synchronous motor and fail-safe brake, from 0.25 kW to 11 kW FCPL: synchronous motor and fail-safe brake, from 15 to 132 kW

3000 range gearboxes combined with the LSRPM and Unidrive M

3000 range geared motors are used to adapt the speed of the **LSRPM 2400 range** motor to that of the driven machine.

Their size is therefore determined by the motor power (P) expressed in kilowatts (kW) and the output rotation speed of the gearbox (nS) in revolutions per minute (min^{-1}).

The main characteristic of speed reducers is the rated output torque (MnS) expressed in Newton-metres (Nm):

$$MnS = P \times 9550/n_s \times \text{efficiency}$$

Compabloc 3000



- A range of eight sizes: 31, 32, 33, 34, 35, 36, 37, 38.
- Rated output torque: 10 N.m to 14,500 N.m.
- Power ratings: from 4.8 to 80 kW.
- Reduction ratios: from 0.79 to 173.
- High efficiency: 95% to 98%.
- Reversible.
- Quiet operation.

Orthobloc 3000



- A range of nine sizes: 31, 32, 33, 34, 35, 36, 37, 38, 39.
- Rated output torque up to 23,000 N.m.
- Power ratings: from 4.8 to 100 kW.
- Reduction ratios: from 5 to 158.
- From two to three reduction stages.
- High efficiency: 95%.
- Reversible.
- Quiet operation.

Manubloc 3000



- A range of eight sizes: 31, 32, 33, 34, 35, 36, 37, 38.
- Rated output torque up to 14,500 N.m.
- Power ratings: from 4.8 to 80 kW.
- Reduction ratios: from 3.92 to 252.
- From two to three reduction stages.
- High efficiency: 95% to 97%.
- Reversible.
- Quiet operation.

Variable speed drive designation

DRIVE

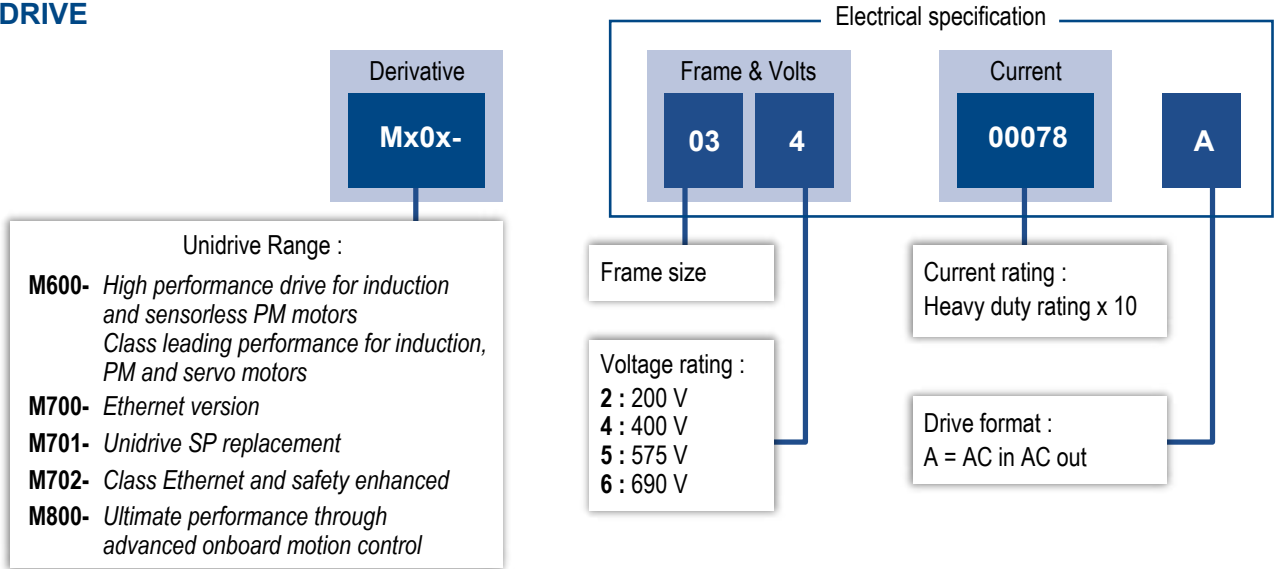

MOTOR

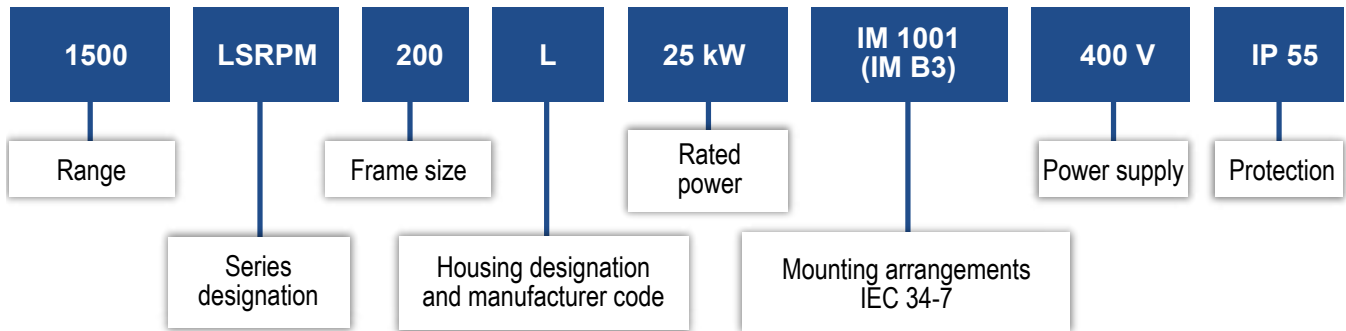

Selection method

Example:

A machine requires a torque of 150 N.m over a speed range of 800 to 1500 min⁻¹ in continuous duty.
The maximum torque is 110%.

Step 1: Choice of motor

a) Selecting the torque range

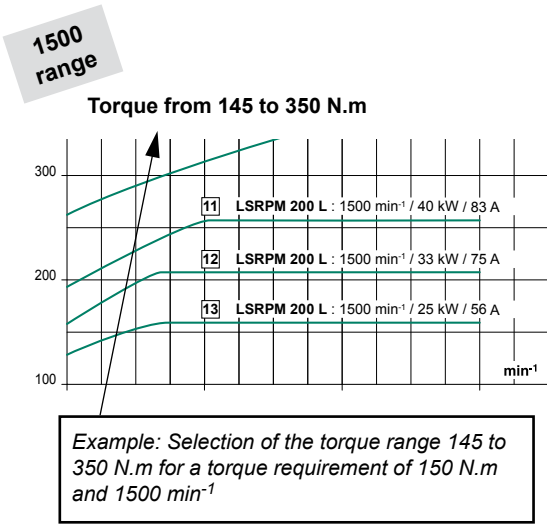

b) Selecting the motor: choose the curve with a torque rating immediately above that required by the application

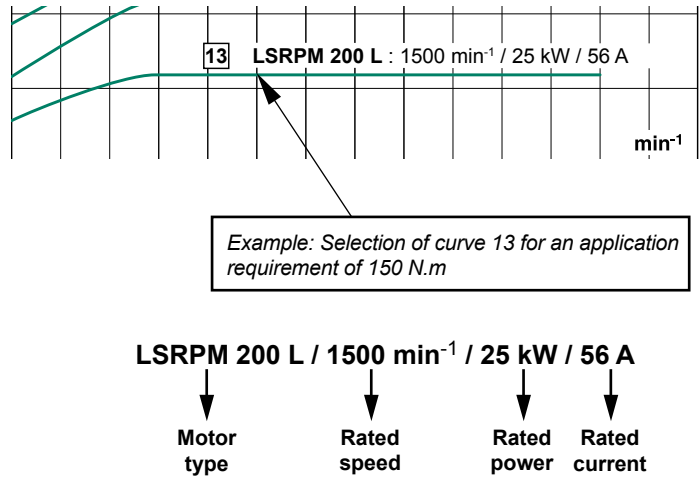

Step 2: Choice of drive

LSRPM 132 M	8.2	91.5	04400150A	8.2	52	1.27	16	1.27	3
			04400172A			1.50		1.50	
LSRPM 132 M	10.2	91.5	04400150A	9.48	60.4	1.10	18.5	1.10	3
			04400172A	10.2	65	1.33	19.9	1.33	
LSRPM 132 M	12	92	04400150A	9.65	61.1	1.10	18.5	1.10	3
			04400172A	12	76	1.15	23	1.15	
LSRPM 160 MP	15.6	92.5	06400350A	15.6	99	1.50	30	1.50	3
			06400350A	18.16	115.4	1.59	35	1.59	
LSRPM 160 MP	19.2	93	06400350A	19.2	122	1.13	37	1.13	3
			06400420A			1.50		1.50	
LSRPM 160 LR	22.8	93.5	06400420A	22.27	141.6	1.54	42	1.54	3
			06400470A	22.8	145	1.50	43	1.50	
LSRPM 200 L	25	94	06400420A	21.43	136.3	1.02	48	1.10	3
			06400470A	25	159	1.15	56	1.24	

Select the drive rating according to the rated and maximum torque required by the application

Example: Selection of drive for an application requiring rated torque of 150 N.m.
M_{max}/M_n = 1.10
Choice of drive: where M_n = 159 N.m and M_m/M_n = 110%

M600 - 06 4 00470 A

Type Size Voltage Rating Format

Efficiency

Emerson Industrial Automation permanent magnet synchronous motors have efficiencies that are higher than those of asynchronous motors and more stable over the entire selected speed range (see graph below).

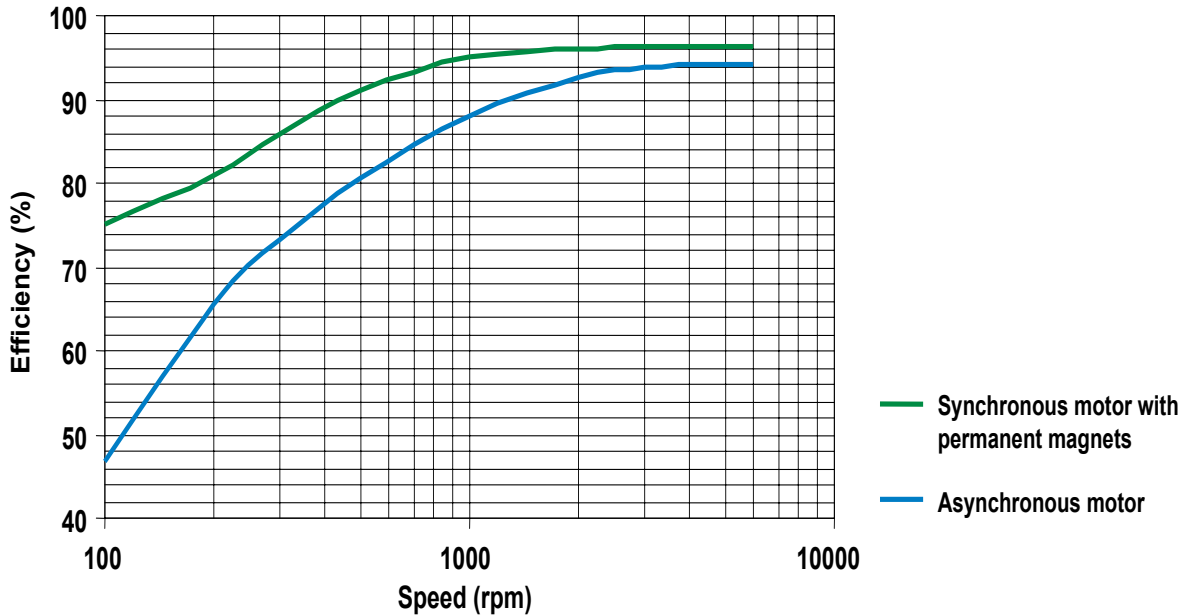

Efficiency of permanent magnet synchronous motors

Apart from a few exceptions, synchronous motors cannot operate correctly on a traditional sinusoidal mains supply. They are practically always supplied via a drive. This catalogue gives the efficiencies of motors supplied via Control Techniques drives.

Efficiencies of asynchronous motors supplied via drives

As a general rule, the efficiencies of asynchronous motors given in the catalogues are values measured on a sinusoidal mains supply at the rated speed.

The voltage and current waveforms created by the drive are not sinusoidal. Supplying power via a drive therefore results in additional losses in the motor. According to specifications 60034-17, these are estimated at 20% of the total losses. These losses have a direct impact on the "displayed" efficiency of the motor.

In variable speed mode, this efficiency should therefore be corrected in accordance with the formula below.

$$n_2 = 1 - (1 - n_1) \times 1.2$$

n_2 = efficiency of asynchronous motor obtained on a drive

n_1 = efficiency of asynchronous motor supplied from the mains

Example of asynchronous/synchronous efficiency: 200 kW application at 3000 min⁻¹

n_1 : Efficiency of the 200 kW, 2-pole asynchronous motor on 50 Hz mains supply = 96%

n_2 : Estimated efficiency of the same asynchronous motor supplied via a drive at 50 Hz

$$n_2 = 1 - (1 - 0.96) \times 1.2 = 0.952 \text{ i.e. } 95.2\%$$

Efficiency of the equivalent synchronous motor = 97.3%

5500 range - 0 to 5500 min⁻¹

Torque from 0 to 24 N.m

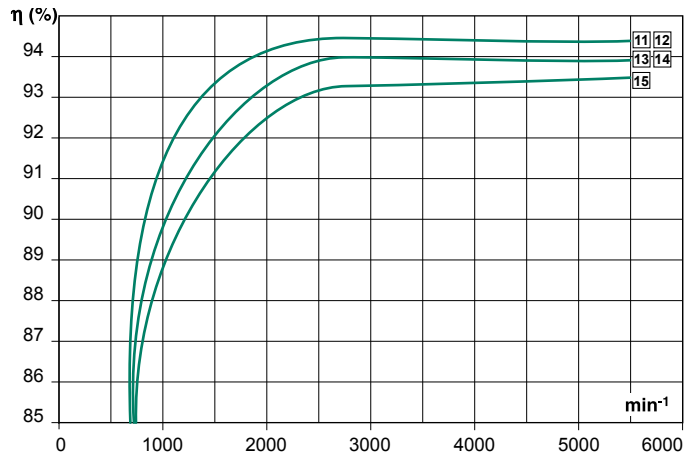
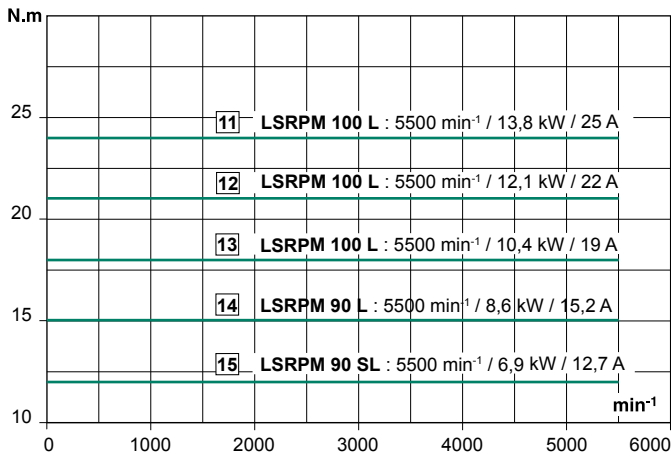

Torque from 24 to 90 N.m

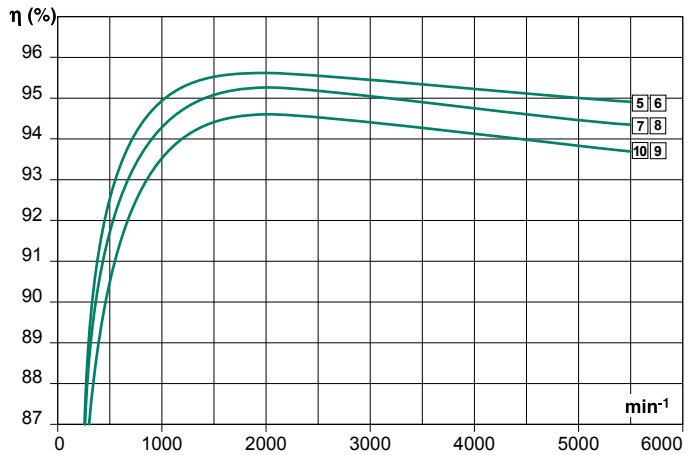
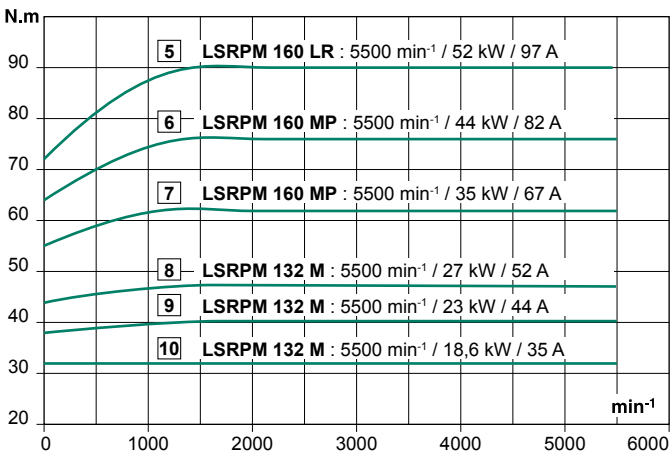

Torque from 90 to 147 N.m

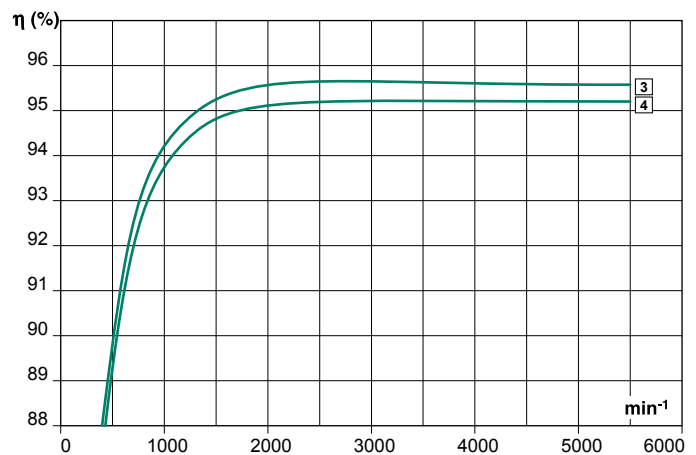
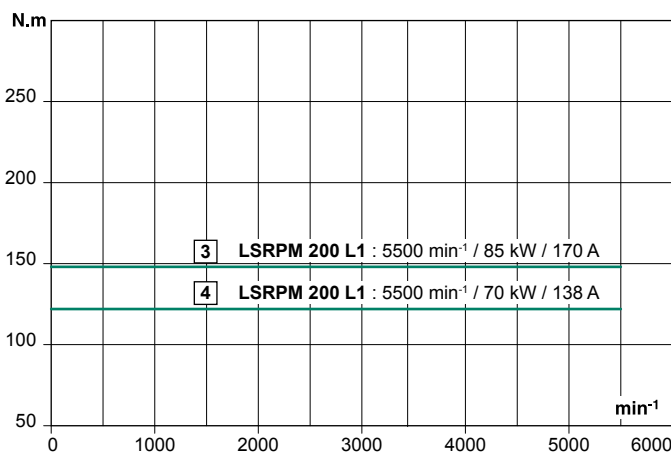

Higher power LSRPM motors are also available (documentation ref. 5006). Please consult us.

4500 range - 0 to 4500 min⁻¹

Torque from 0 to 29 N.m

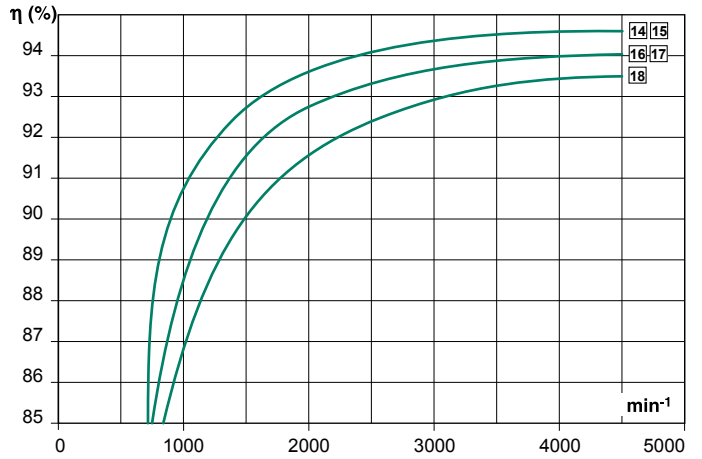
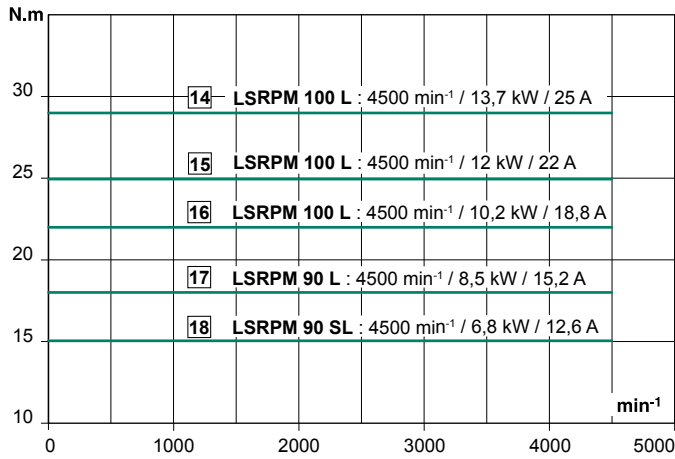

Torque from 29 to 110 N.m

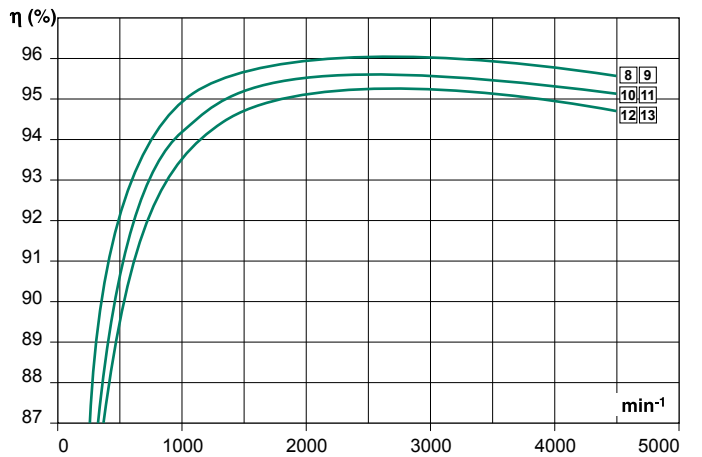
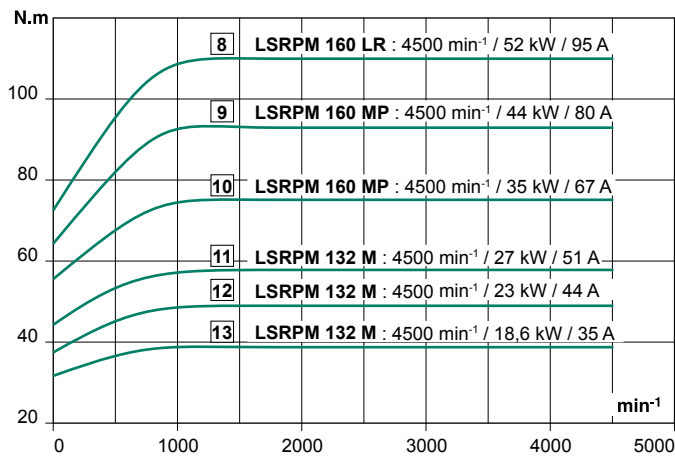

Torque from 110 to 170 N.m

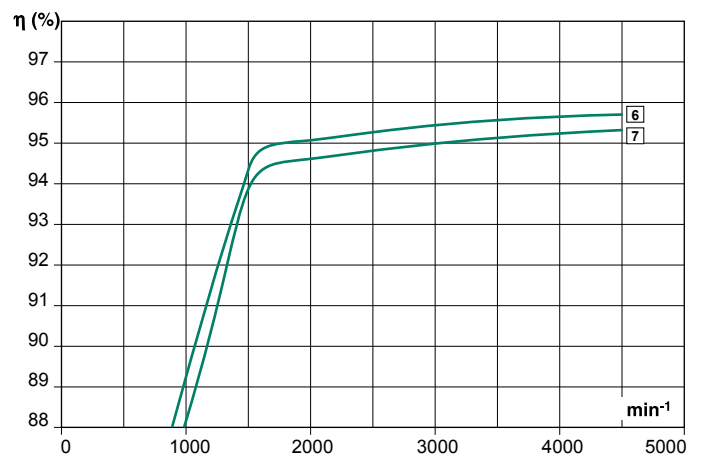
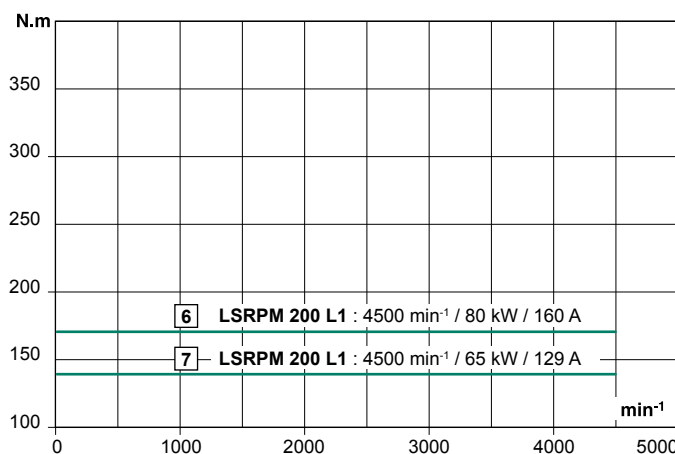

Higher power LSRPM motors are also available (documentation ref. 5006). Please consult us.

3600 range - 0 to 3600 min⁻¹

Torque from 0 to 34 N.m

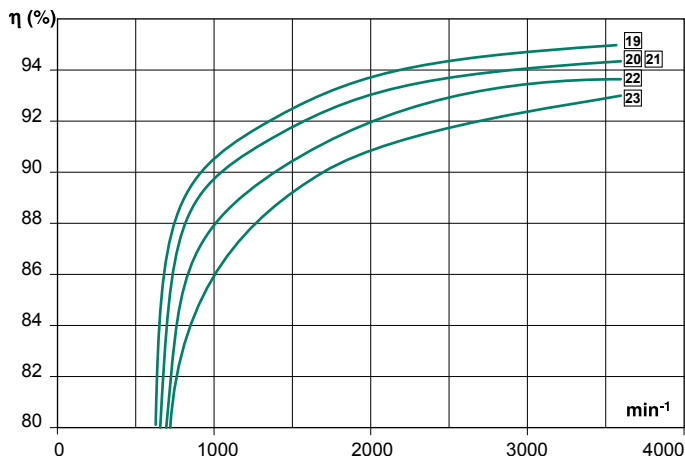
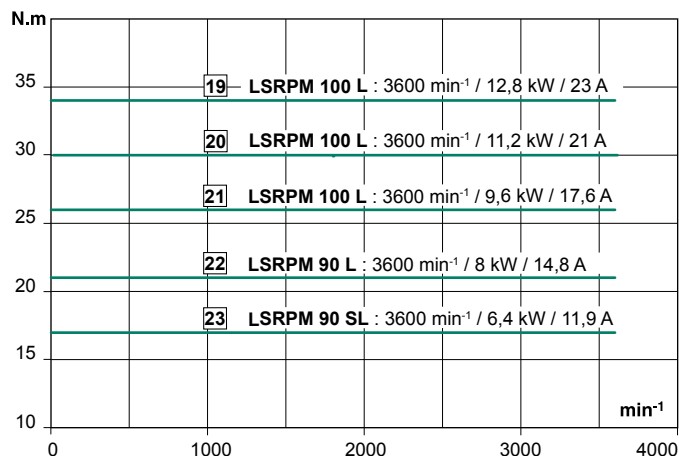

Torque from 34 to 130 N.m

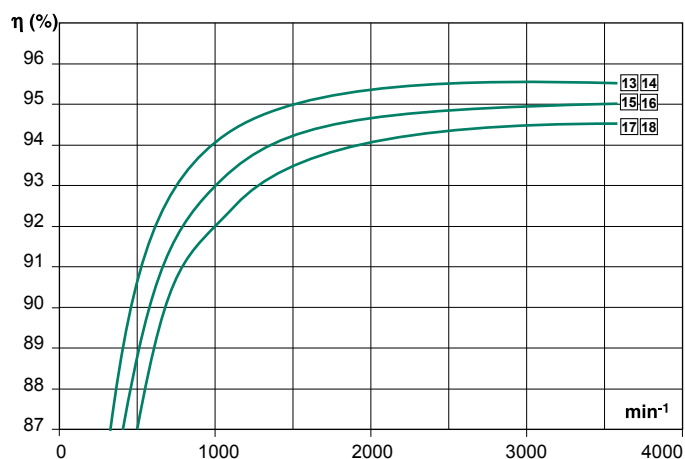
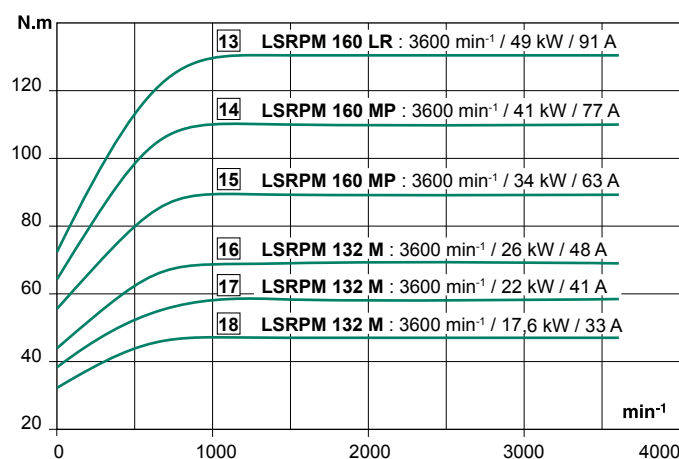

Torque from 130 to 225 N.m

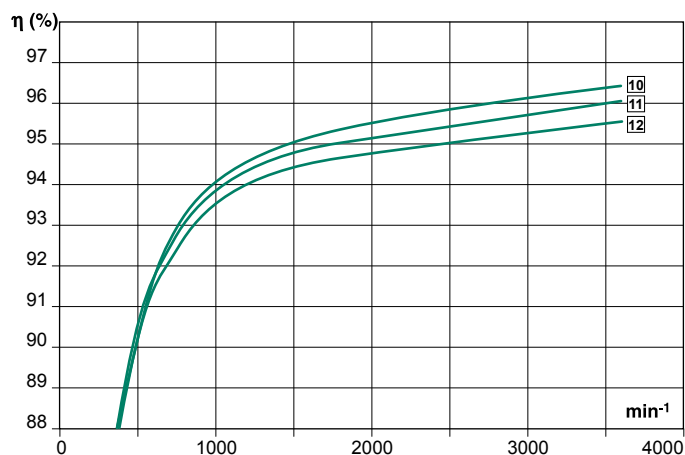
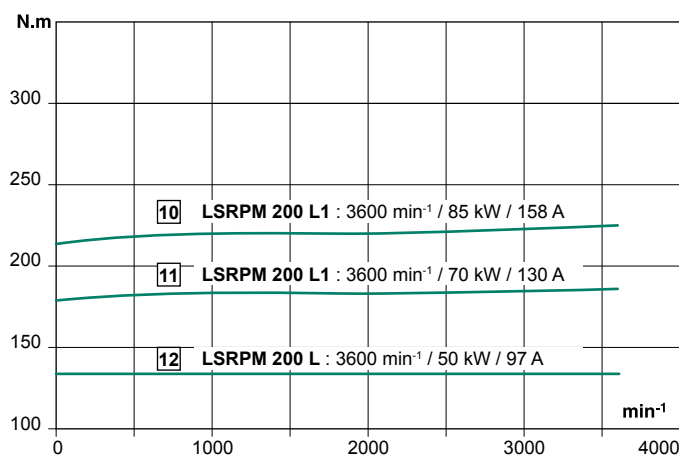

Higher power LSRPM motors are also available (documentation ref. 5006). Please consult us.

3000 range - 0 to 3000 min⁻¹

Torque from 0 to 37 N.m

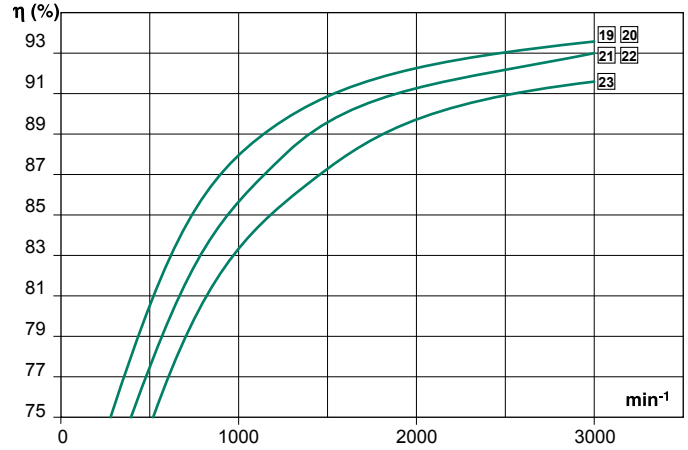
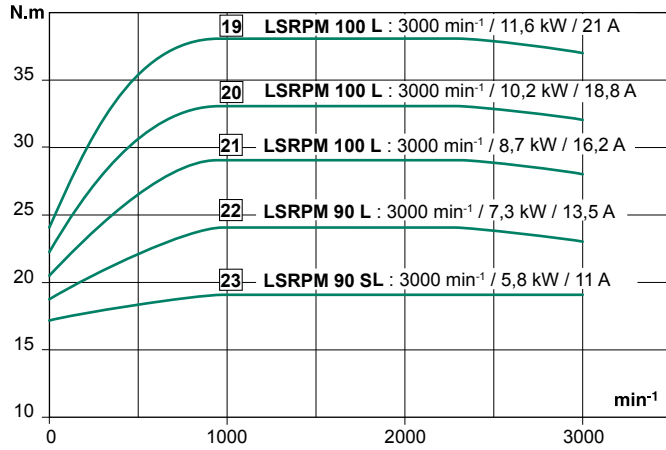

Torque from 37 to 140 N.m

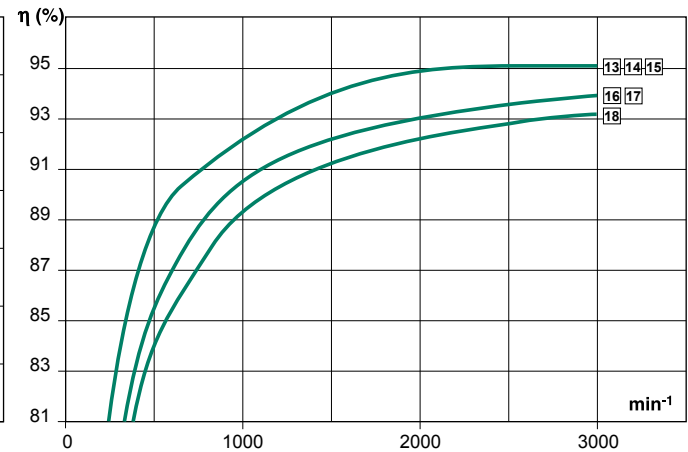
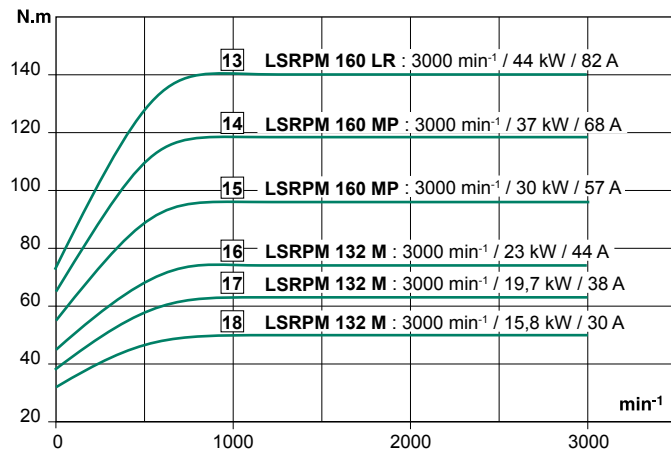

Torque from 140 to 271 N.m

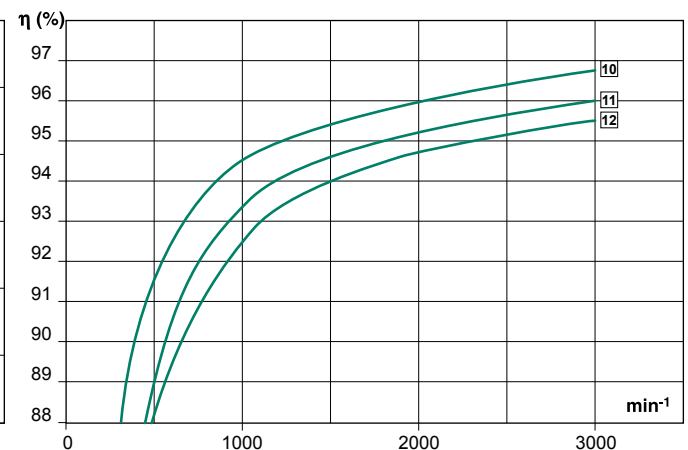
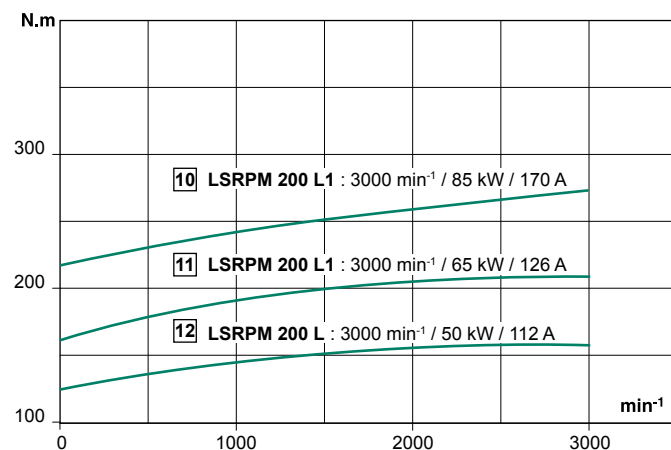

Higher power LSRPM motors are also available (documentation ref. 5006). Please consult us.

2400 range - 0 to 2400 min⁻¹

Torque from 0 to 38 N.m

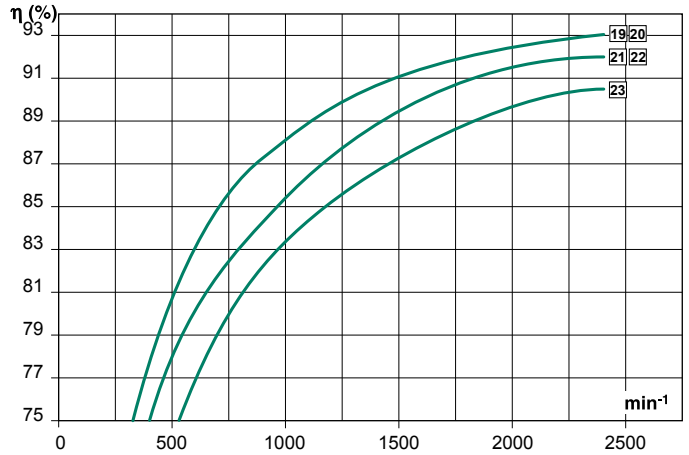
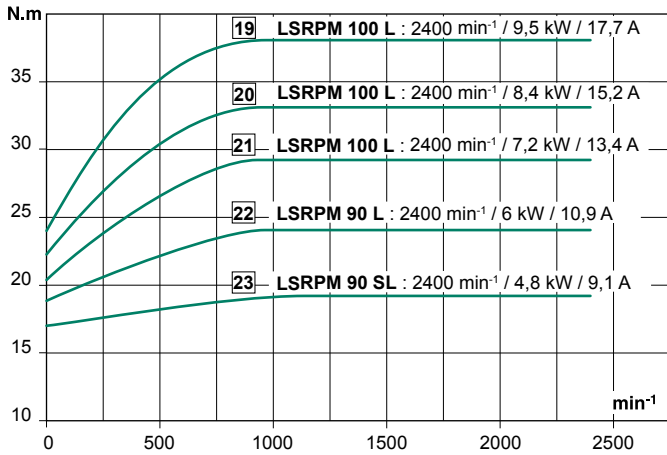

Torque from 38 to 145 N.m

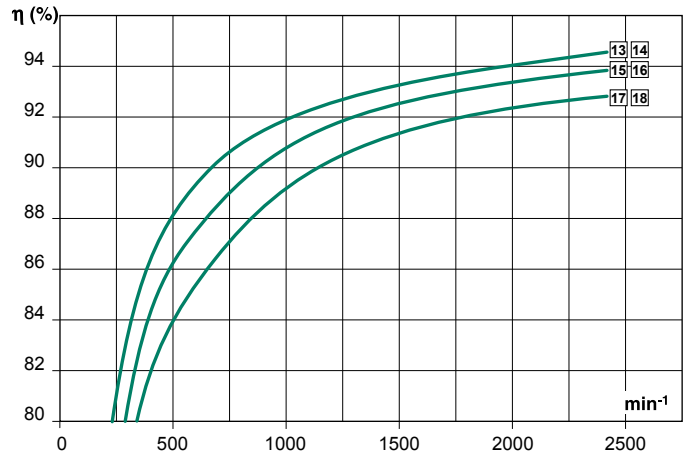
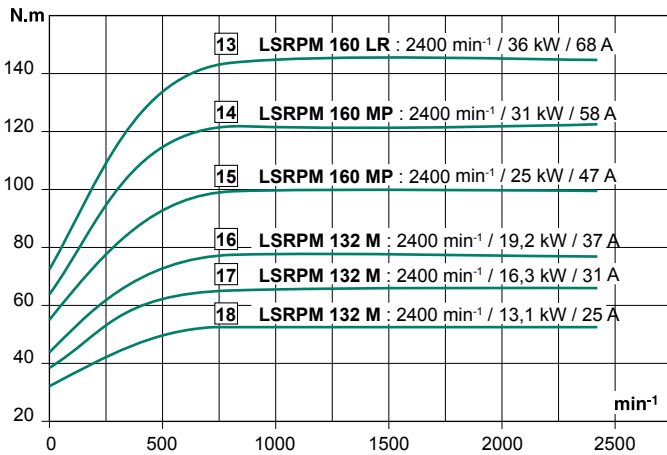

Torque from 145 to 320 N.m

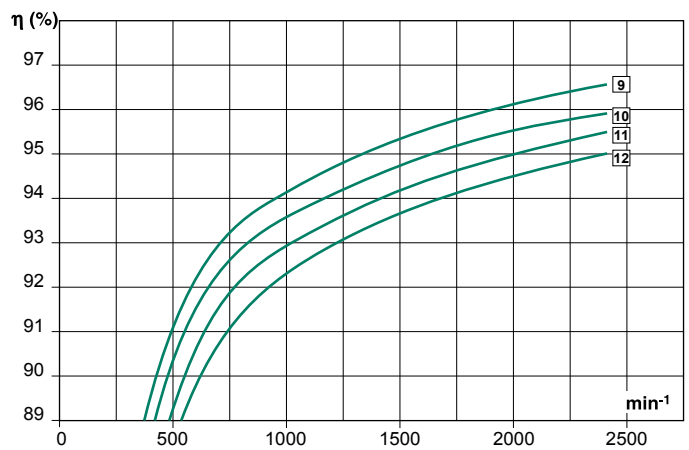
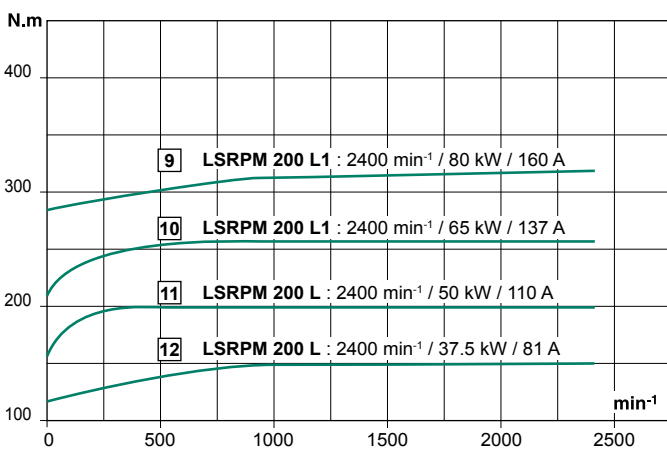

Higher power LSRPM motors are also available (documentation ref. 5006). Please consult us.

1800 range - 0 to 1800 min⁻¹

Torque from 0 to 38 N.m

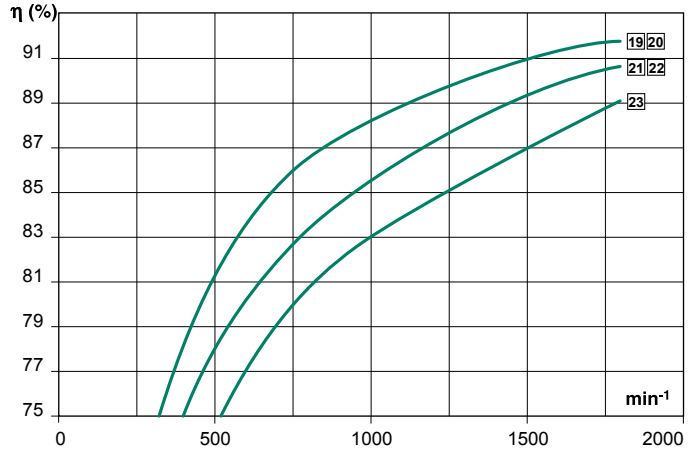
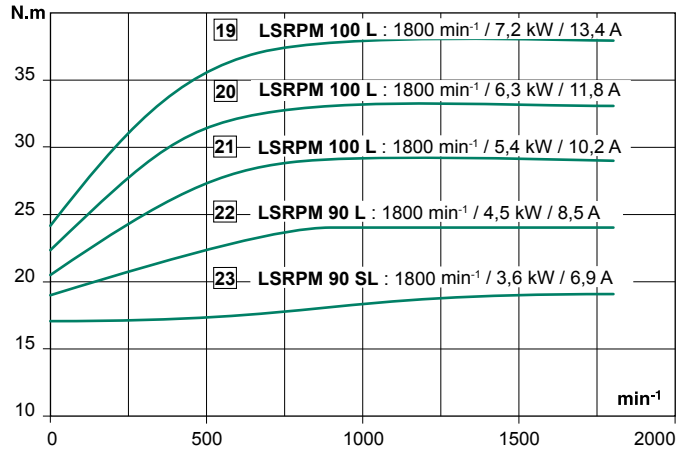

Torque from 38 to 145 N.m

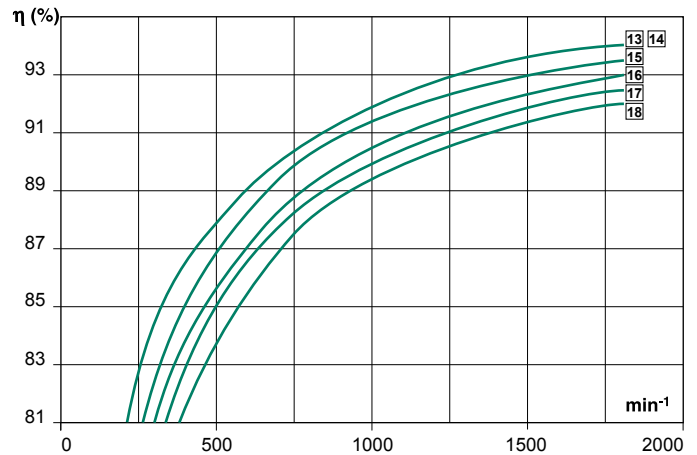
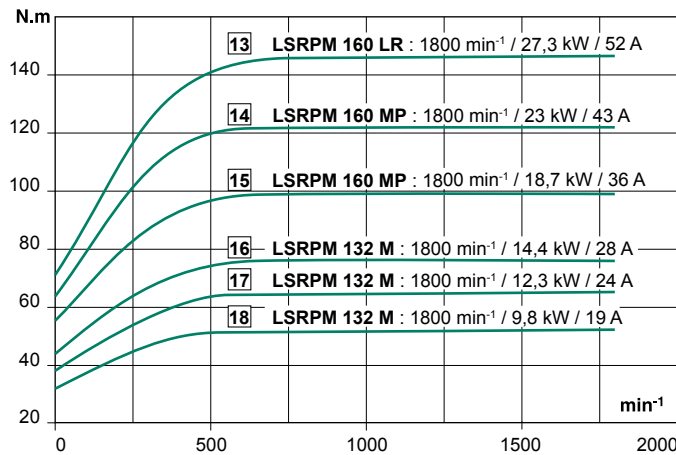

Torque from 145 to 450 N.m

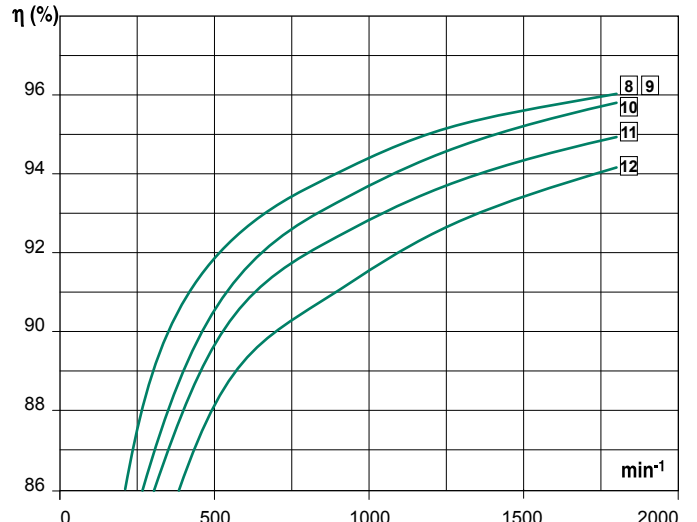
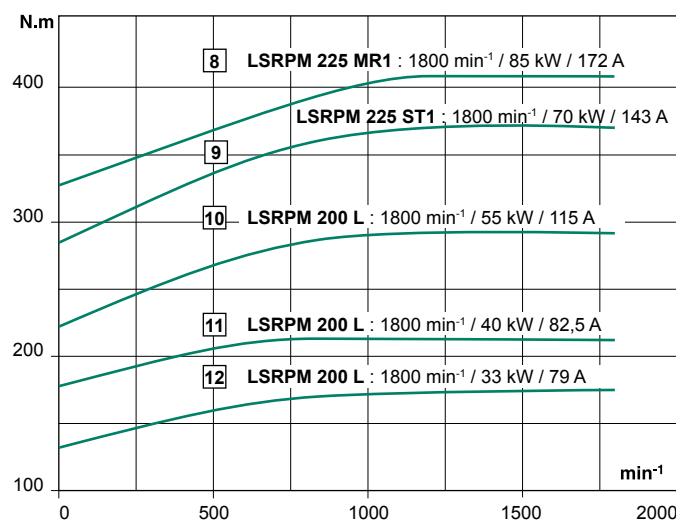

Higher power LSRPM motors are also available (documentation ref. 5006). Please consult us.

1500 range - 0 to 1500 min⁻¹

Torque from 0 to 38 N.m

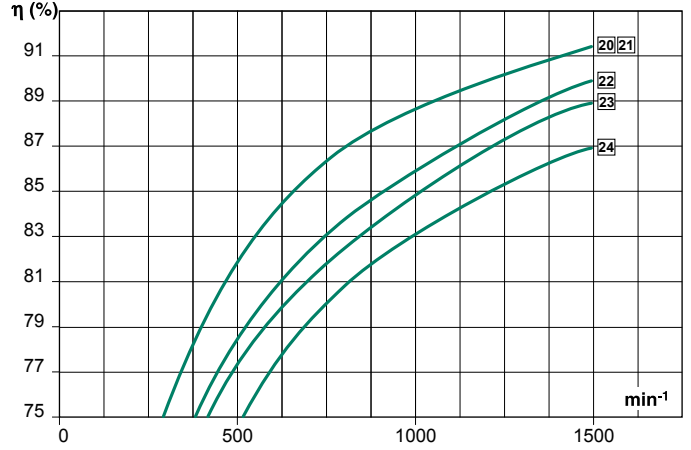
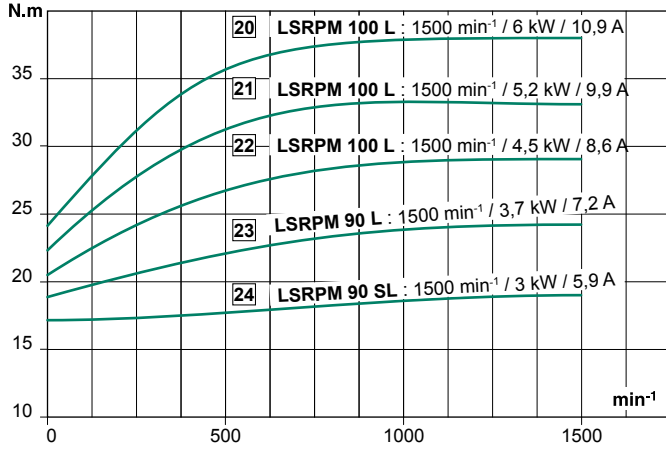

Torque from 38 to 145 N.m

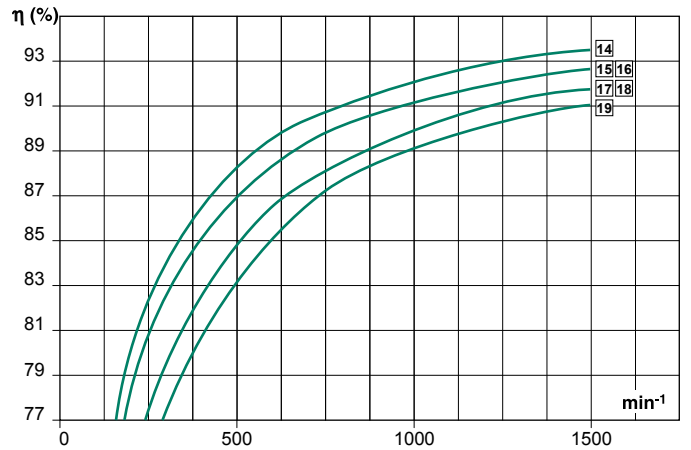
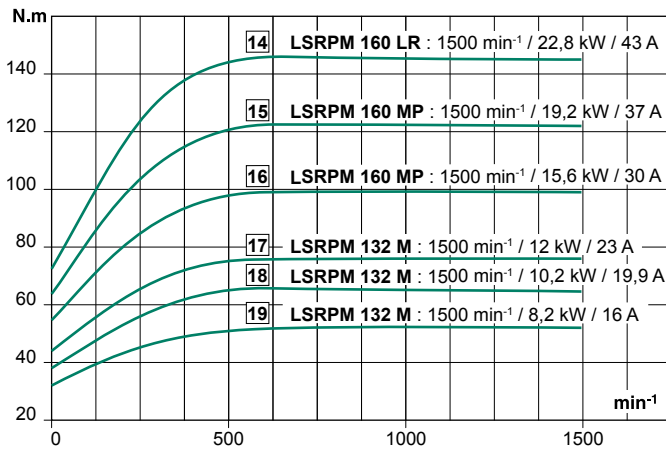

Torque from 145 to 350 N.m

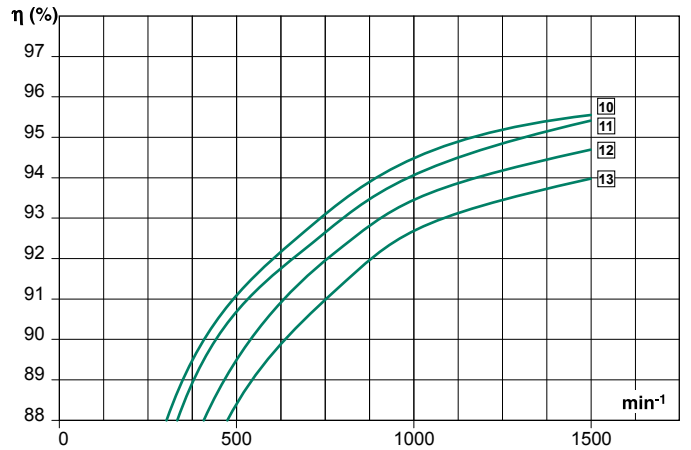
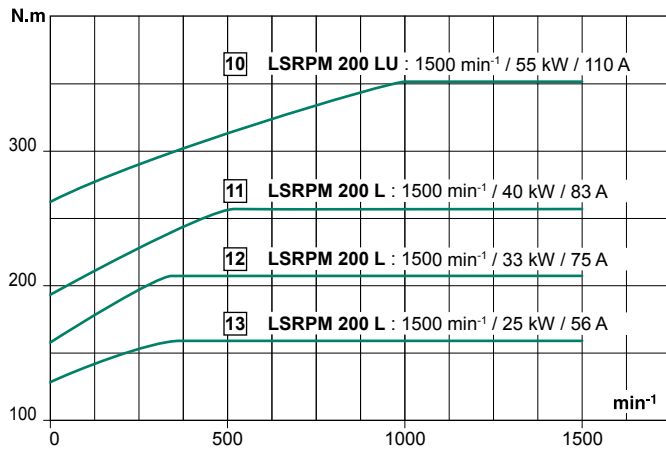

1500 range - 0 to 1500 min⁻¹

Torque from 350 to 550 N.m

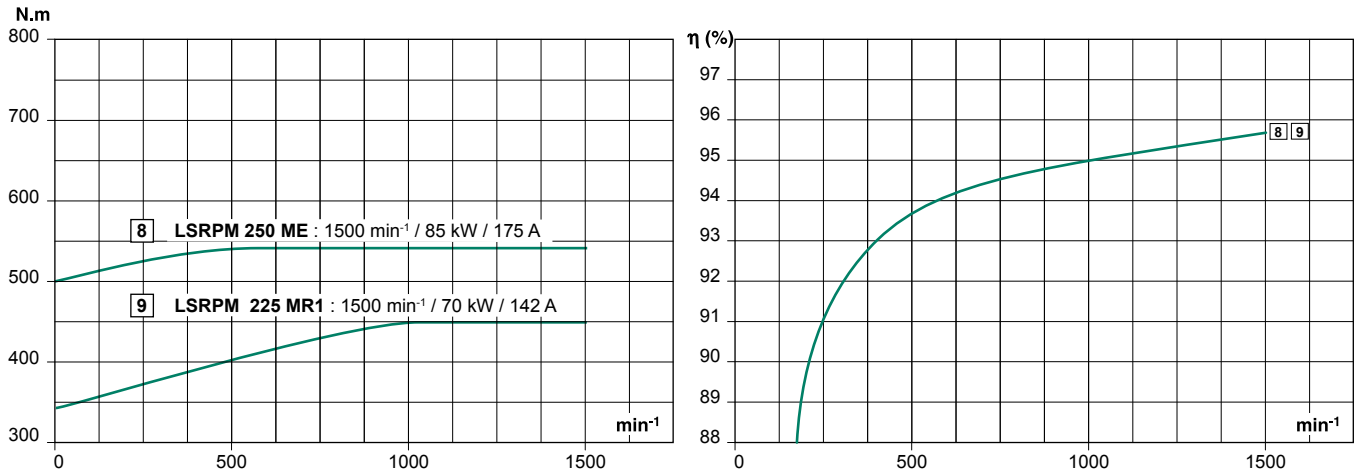

Higher power LSRPM motors are also available (documentation ref. 5006). Please consult us.

900 range - 0 to 900 min⁻¹

Torque from 0 to 38 N.m

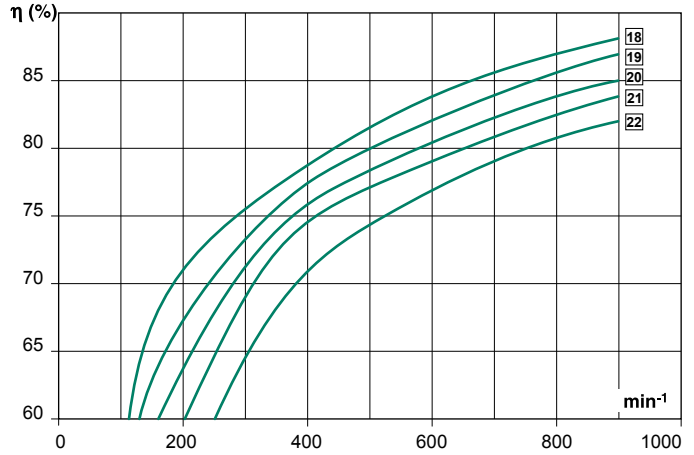
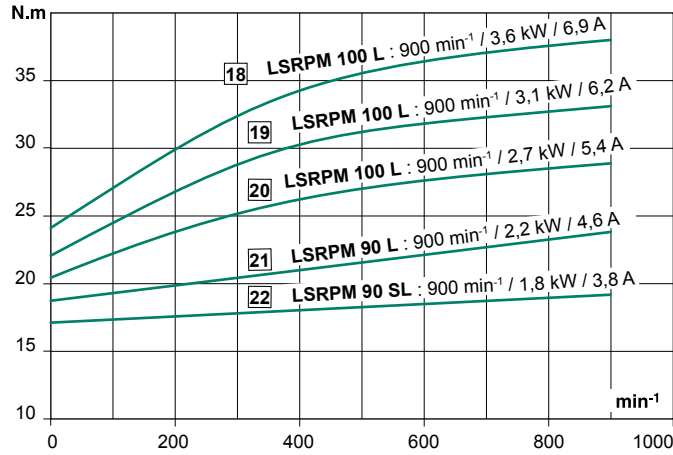

Torque from 38 to 145 N.m

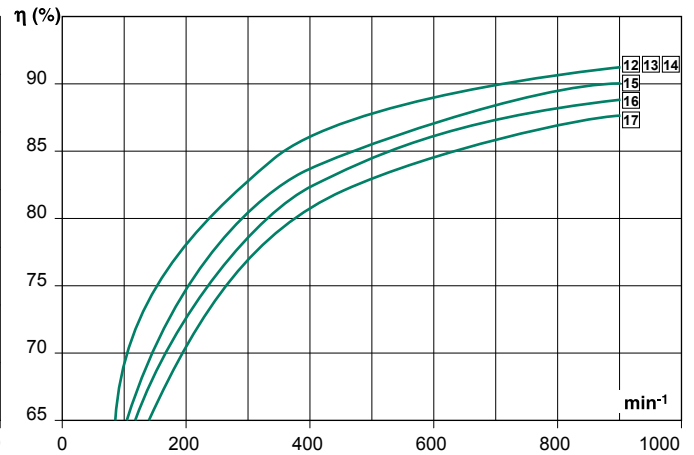
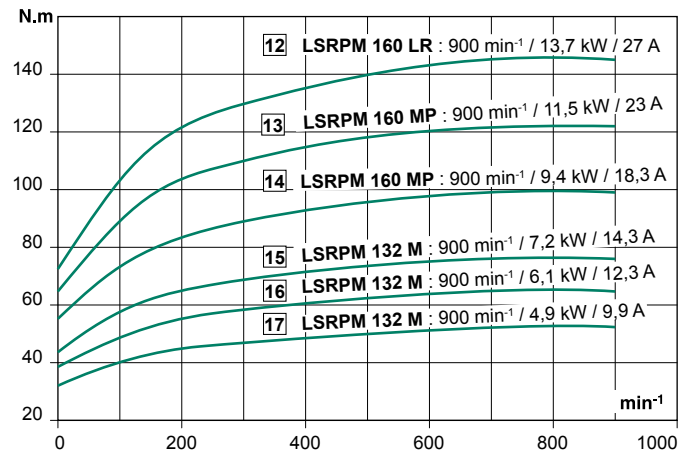

Torque from 145 to 350 N.m

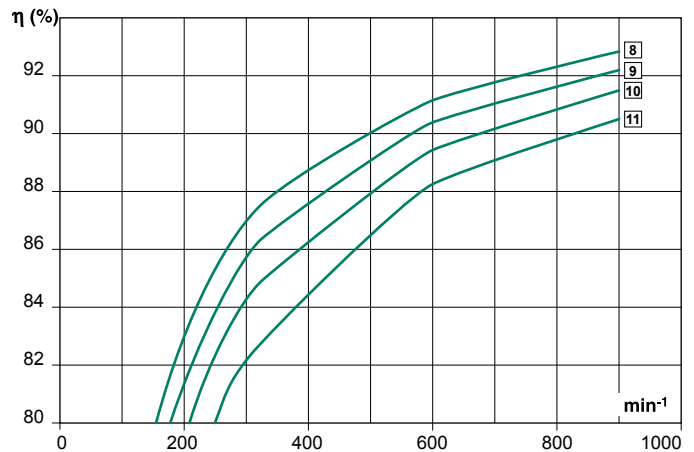
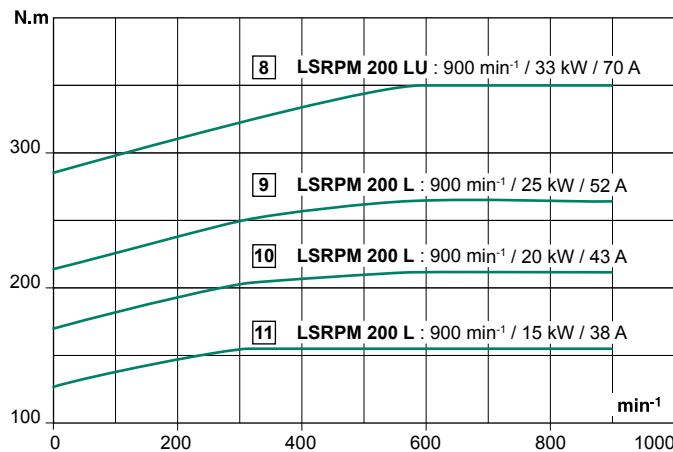

900 range - 0 to 900 min⁻¹

Torque from 350 to 800 N.m

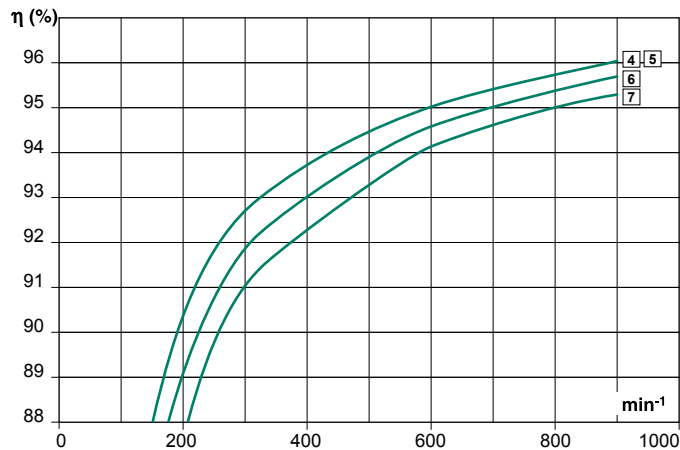
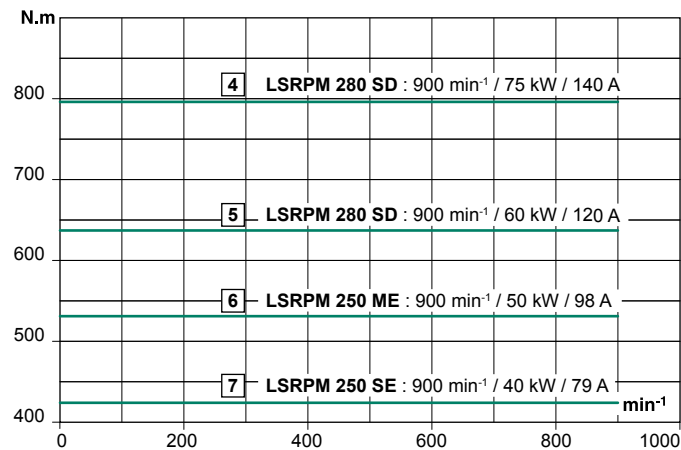

Torque from 800 to 900 N.m

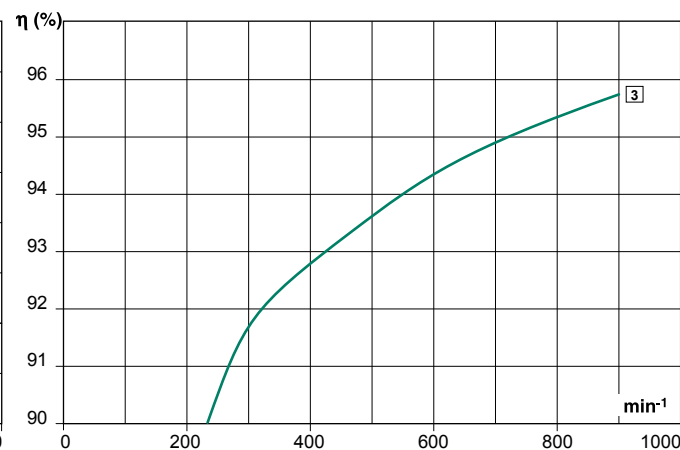
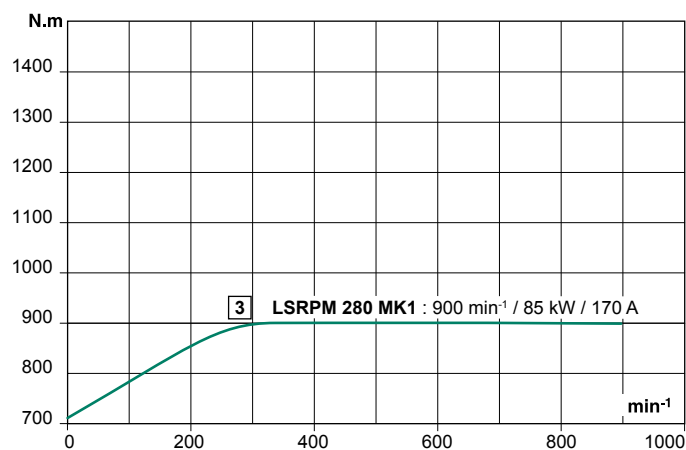

Higher power LSRPM motors are also available (documentation ref. 5006). Please consult us.

750 range - 0 to 750 min⁻¹

Torque from 0 to 37 N.m

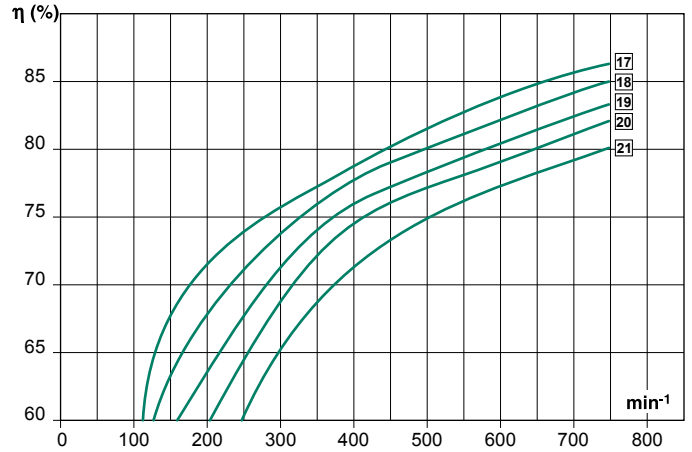
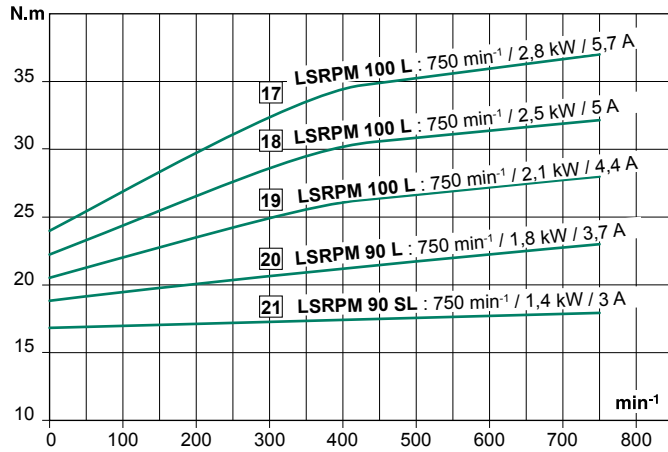

Torque from 37 to 145 N.m

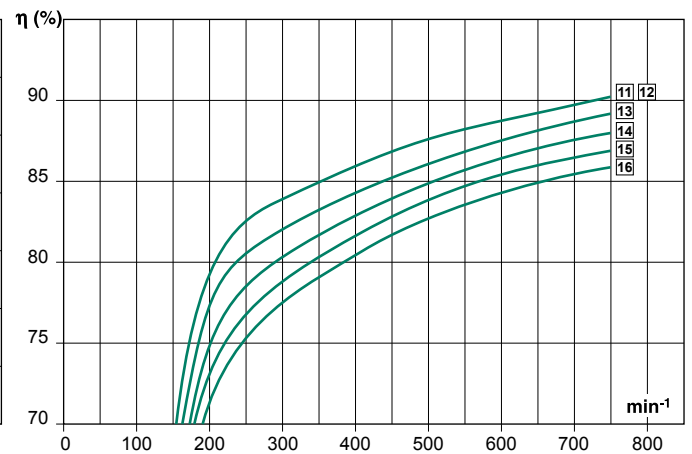
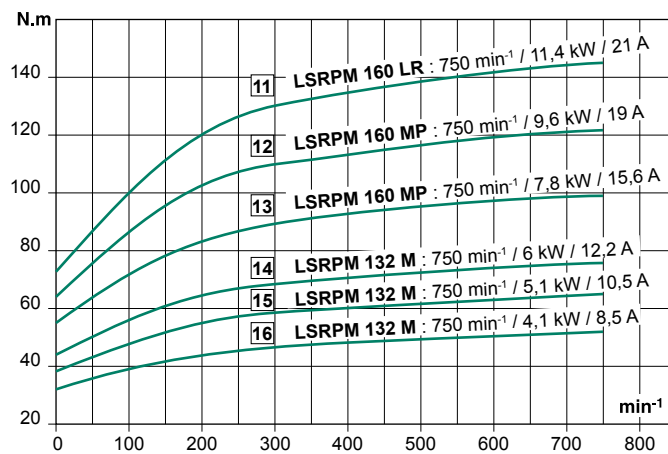

Torque from 145 to 345 N.m

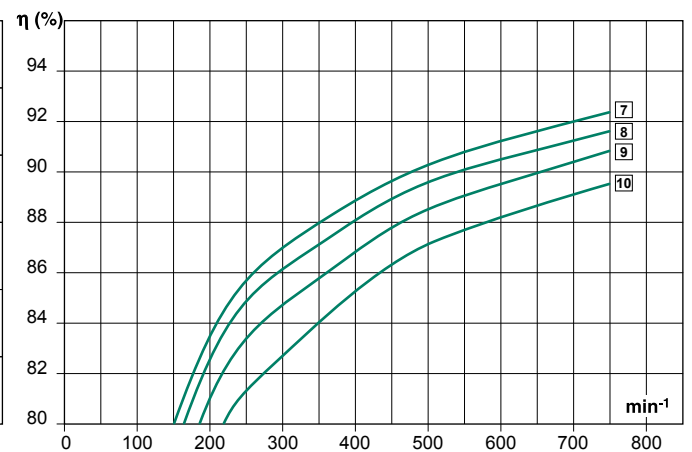
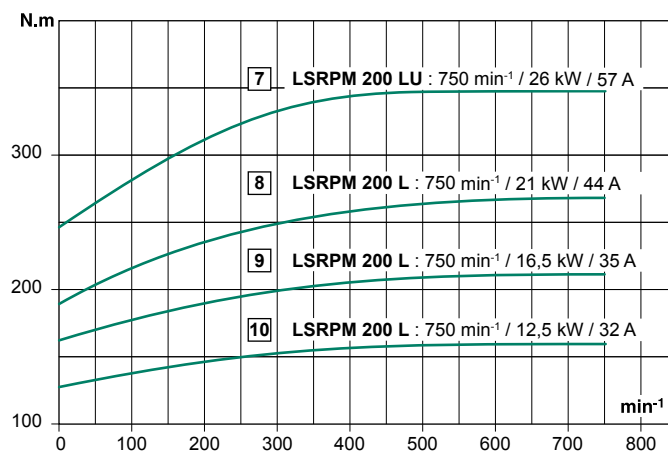

750 range - 0 to 750 min⁻¹

Torque from 345 to 890 N.m

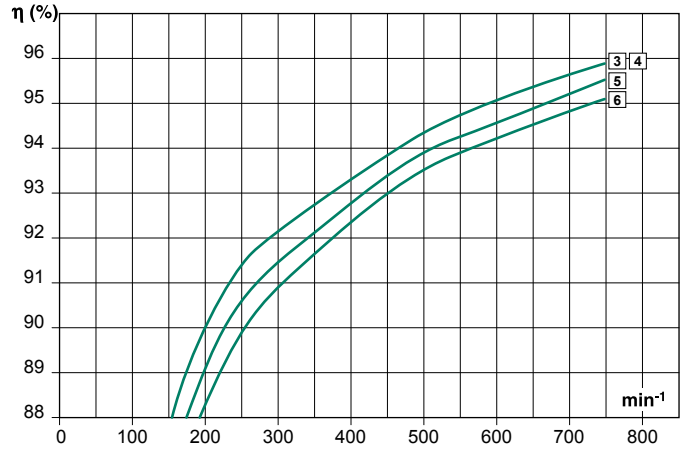
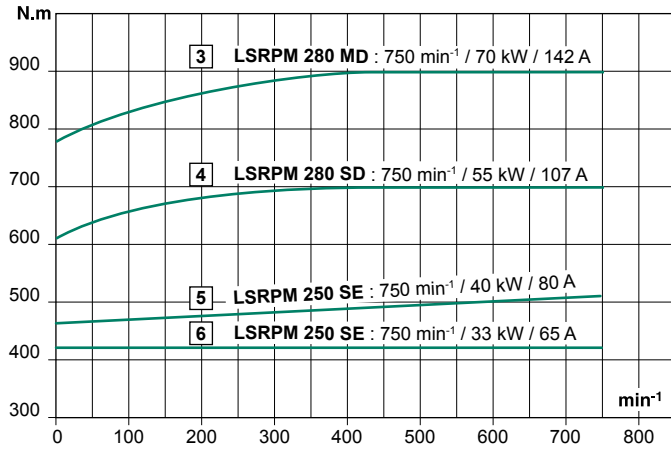

Torque from 890 to 1100 N.m

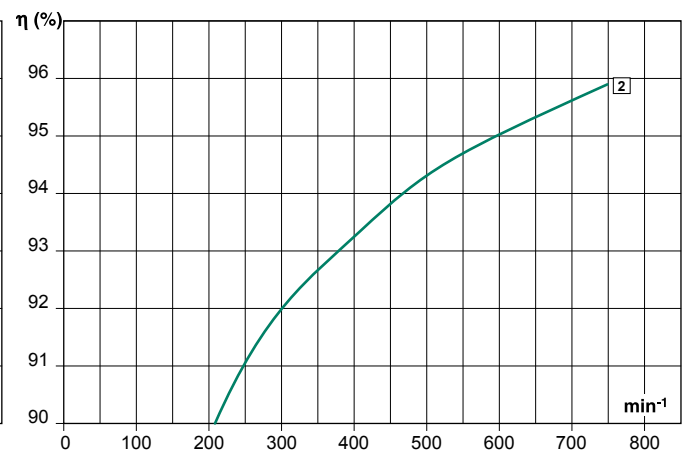
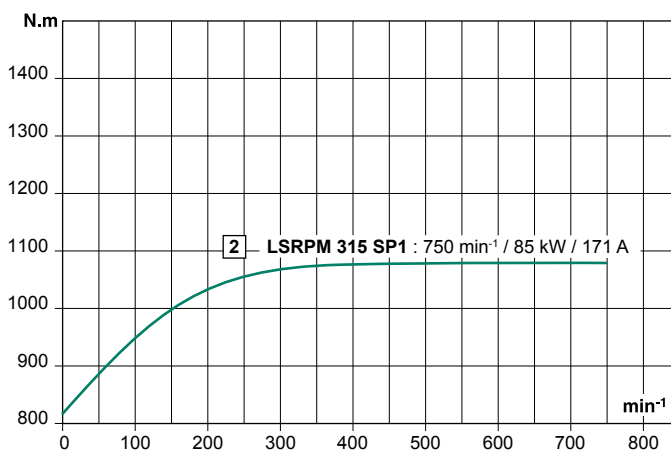

Higher power LSRPM motors are also available (documentation ref. 5006). Please consult us.

DYNEO® VARIABLE SPEED DRIVES

Unidrive M variable speed drives/LSRPM permanent magnet synchronous motors Selection

5500 range

Class F - DT80K - S1 Self-Cooled - Altitude 1000 m max - Ambient temperature 40°C max

Power supply upstream from the drive 400 V (in accordance with IEC 60034-1)

11	Drive limit
12.7	Motor limit

MOTOR			DRIVE	VARIABLE SPEED MOTOR							MOTOR				
Type	Rated power	Efficiency IEC 60034-2-1 2007	Type Unidrive M 600/700/800 (1)	Available power	Rated torque	Maximum torque/ Rated torque	Rated current	Maximum current/ Rated current	Minimum switching frequency	Efficiency	Moment of inertia	Weight			
	P _n kW	η 4/4		P _n kW	M _n N.m	M _m /M _n (2)	I _n A (3)	I _m /I _n (4)	F _D kHz (5)	η 4/4	J kg.m ²	IM B3 kg			
LSRPM 90 SL	6.9	93.5	044-00150A (H)	6.9	12	1.50	12.7	1.50	6	0.93	0.0032	14			
			044-00150A (H)	8.16	14.2	1.50	15 (15.8)	1.50							
LSRPM 90 L	8.6	94	044-00150A (N)	8.6	15	1.29	15.8	1.28	6	0.94	0.0051	17			
			044-00172A (H)			1.50		1.50							
			054-00270A (H)			1.50		1.50							
LSRPM 100 L	10.4	94	044-00172A (N)	10.4	18	1.39	19	1.39	6	0.94	0.006	19			
			054-00270A (H)			1.50		1.50							
			054-00270A (H)			1.50		1.50							
LSRPM 100 L	12.1	94.5	044-00172A (N)	11.99	20.8	1.20	21.8 (22)	1.20	6	0.94	0.0078	24			
			054-00270A (N)			12.1		21					1.50	22	1.50
			054-00300A (H)			13.25		23					1.50	24 (25)	1.50
LSRPM 100 L	13.8	94.5	054-00270A (N)	13.8	24	1.32	25	1.32	6	0.94	0.009	26			
			054-00300A (N)			1.36		1.36							
			064-00350A (H)			1.50		1.50							
LSRPM 132 M	18.6	94	064-00350A (H)	18.6	32	1.50	35	1.50	6	0.94	0.0165	40			
			064-00420A (N)			1.20		1.20							
			064-00470A (N)			1.50		1.50							
LSRPM 132 M	23	94	074-00660A (H)	23	40	1.50	44	1.50	6	0.94	0.0231	44			
			064-00470A (N)			24.92		43.4					1.33	48 (52)	1.33
			074-00660A (H)			27		47					1.50	52	1.50
LSRPM 160 MP	35	94.5	074-00770A (H)	35	62	1.50	59 (67)	1.50	6	0.94	0.0418	60			
			074-00660A (N)			1.30		67					1.30		
			074-01000A (H)			1.50		1.50							
LSRPM 160 MP	44	95	074-01000A (H)	39.17	67.7	1.50	73 (82)	1.50	6	0.95	0.0514	69			
			074-00770A (N)			1.26		82					1.26		
			074-01000A (N)			1.50		1.50							
LSRPM 160 LR	52	95	074-01000A (N)	51.04	88.3	1.27	95.2 (97)	1.27	6	0.95	0.0626	79			
			084-01340A (H)			52		90					1.50	97	1.50
LSRPM 200 L1	70	95.2	084-01570A (H)	61.38	107	1.40	121 (138)	1.50	6	0.95	0.13	138			
LSRPM 200 L1			084-01340A (N)			1.15		138					1.24		
LSRPM 200 L1			084-01570A (N)			1.37		1.47							
LSRPM 200 L1	85	95.4	084-01570A (N)	84.5	147.1	1.11	169 (170)	1.19	6	0.95	0.15	148			

(1) N = Normal duty
H = Heavy duty

(2) Motor and drive maximum torque / Motor rated torque

(3) Motor and drive rated current. If the motor rated current is higher, the value is mentioned between the brackets. The motor rated current must be set at parameter 00.046 {05.007}.

(4) Motor and drive maximum current / Motor rated current. This value must be set at parameter 00.006 {04.007}.

(5) Minimum switching frequency. This value must be set at parameter 00.041 {05.018}. The « disable auto switching frequency change » parameter {05.035} must be set to ON.

DYNEO® VARIABLE SPEED DRIVES

Unidrive M variable speed drives/LSRPM permanent magnet synchronous motors Selection

4500 range

Class F - DT80K - S1 Self-Cooled - Altitude 1000 m max - Ambient temperature 40°C max

Power supply upstream from the drive 400 V (in accordance with IEC 60034-1)

11	Drive limit
12.6	Motor limit

MOTOR			DRIVE	VARIABLE SPEED MOTOR							MOTOR	
Type	Rated power	Efficiency IEC 60034-2-1 2007	Type Unidrive M 600/700/800 (1)	Available power	Rated torque	Maximum torque/ Rated torque	Rated current	Maximum current/ Rated current	Minimum switching frequency	Efficiency	Moment of inertia	Weight
	P _n kW	η 4/4		P _n kW	M _n N.m	M _m /M _n (2)	I _n A (3)	I _m /I _n (4)	F _D kHz (5)	η 4/4	J kg.m ²	IM B3 kg
LSRPM 90 SL	6.8	93.5	044-00150A (H)	6.8	15	1.50	12.6	1.50	6	0.93	0.0032	14
LSRPM 90 L			044-00150A (H)	8.12	17.2	1.50	15 (15.7)	1.50				
LSRPM 90 L	8.5	94	044-00150A (N)	8.5	18	1.29	15.7	1.29	6	0.94	0.0051	17
LSRPM 90 L			044-00172A (H)			1.50		1.50				
LSRPM 100 L	10.2	94	044-00172A (N)	10.2	22	1.40	18.8	1.40	6	0.94	0.006	19
LSRPM 100 L			054-00270A (H)			1.50		1.50				
LSRPM 100 L			054-00270A (H)	11.07	23.1	1.50	20.3 (22)	1.50				
LSRPM 100 L	12	94.5	044-00172A (N)	11.89	24.8	1.20	21.8 (22)	1.20	6	0.94	0.0078	24
LSRPM 100 L			054-00270A (N)			12		25				
LSRPM 100 L			054-00300A (H)	13.15	27.8	1.50	24 (25)	1.50				
LSRPM 100 L	13.7	94.5	054-00270A (N)	13.7	29	1.32	25	1.32	6	0.94	0.009	26
LSRPM 100 L			054-00300A (N)			1.37		1.36				
LSRPM 132 M	18.6	94.5	064-00350A (H)	18.6	39	1.50	35	1.50	6	0.94	0.0165	40
LSRPM 132 M			064-00420A (N)	23	49	1.20	44	1.20	6	0.94	0.0231	44
LSRPM 132 M	23	94.5	064-00470A (N)			1.50		1.50				
LSRPM 132 M			064-00470A (N)	25.41	54.6	1.36	48 (51)	1.36	6	0.95	0.0311	49
LSRPM 132 M	27	95	074-00660A (H)	27	58	1.50	51	1.50				
LSRPM 160 MP			074-00770A (H)	30.82	66	1.50	59 (67)	1.50				
LSRPM 160 MP	35	95	074-00660A (N)	35	75	1.30	67	1.30	6	0.95	0.0418	60
LSRPM 160 MP			074-01000A (H)			1.50		1.50				
LSRPM 160 MP			074-01000A (H)	40.15	84.9	1.50	73 (80)	1.50				
LSRPM 160 MP	44	95.5	074-00770A (N)	44	93	1.29	80	1.29	6	0.95	0.0514	69
LSRPM 160 MP			074-01000A (N)			1.50		1.50				
LSRPM 160 LR			074-01000A (N)	51.04	108	1.27	95.2 (97)	1.27				
LSRPM 160 LR	52	95.5	084-01340A (H)	52	110	1.50	97	1.50	6	0.95	0.0626	79
LSRPM 200 L1			084-01570A (H)	60.5	128.4	1.40	121 (130)	1.50				
LSRPM 200 L1	65	95.3	084-01340A (N)	65	138	1.22	130	1.31	6	0.95	0.13	138
LSRPM 200 L1	80	95.7	084-01570A (N)	80	170	1.18	160	1.27	6	0.96	0.15	148

(1) N = Normal duty
H = Heavy duty

(2) Motor and drive maximum torque / Motor rated torque

(3) Motor and drive rated current. If the motor rated current is higher, the value is mentioned between the brackets. The motor rated current must be set at parameter 00.046 {05.007}.

(4) Motor and drive maximum current / Motor rated current. This value must be set at parameter 00.006 {04.007}.

(5) Minimum switching frequency. This value must be set at parameter 00.041 {05.018}. The « disable auto switching frequency change » parameter {05.035} must be set to ON.

DYNEO® VARIABLE SPEED DRIVES

Unidrive M variable speed drives/LSRPM permanent magnet synchronous motors Selection

3600 range

Class F - DT80K - S1 Self-Cooled - Altitude 1000 m max - Ambient temperature 40°C max

Power supply upstream from the drive 400 V (in accordance with IEC 60034-1)

11	Drive limit
11.9	Motor limit

MOTOR			DRIVE	VARIABLE SPEED MOTOR							MOTOR		
Type	Rated power	Efficiency IEC 60034-2-1 2007	Type Unidrive M 600/700/800 (1)	Available power	Rated torque	Maximum torque/ Rated torque	Rated current	Maximum current/ Rated current	Minimum switching frequency	Efficiency	Moment of inertia	Weight	
	P_n kW	η 4/4		P_n kW	M_n N.m	M_m/M_n (2)	I_n A (3)	I_m/I_n (4)	F_D kHz (5)	η 4/4	J kg.m ²	IM B3 kg	
LSRPM 90 SL	6.4	93	034-00100A (N)	6.4	17	1.14	11.9	1.13	4	0.93	0.0032	14	
LSRPM 90 SL			044-00150A (H)			1.50		1.50					
LSRPM 90 L	8	93.5	044-00150A (H)	8	21	1.50	14.8	1.50	4	0.93	0.0051	17	
LSRPM 100 L	9.6	94	044-00172A (H)	9.38	25.4	1.50	17.2 (17.6)	1.50	4	0.94	0.006	19	
LSRPM 100 L			044-00150A (N)	9.6	26	1.15	17.6	1.15					
LSRPM 100 L	11.2	94	044-00172A (N)	11.2	30	1.26	21	1.26	4	0.94	0.0078	24	
LSRPM 100 L			054-00270A (H)			1.50		1.50					
LSRPM 100 L	12.8	94.5	044-00172A (N)	12.8	34	1.15	23	1.15	4	0.94	0.009	26	
LSRPM 100 L			054-00270A (H)			1.50		1.50					
LSRPM 132 M	17.6	94.5	064-00350A (H)	17.6	47	1.50	33	1.50	4	0.94	0.0165	40	
LSRPM 132 M	22	94.5	064-00420A (H)	22	58	1.50	41	1.50	4	0.94	0.0231	44	
LSRPM 132 M			064-00420A (H)			22.75		60.4					1.50
LSRPM 132 M	26	95	064-00420A (N)	26	69	1.10	48	1.10	4	0.95	0.0311	49	
LSRPM 132 M			064-00470A (N)			1.44		1.44					
LSRPM 160 MP	34	95	064-00470A (N)	30.76	80.5	1.10	57 (63)	1.10	4	0.95	0.0418	60	
LSRPM 160 MP			074-00660A (H)			34		89					1.50
LSRPM 160 MP	41	95.5	074-00770A (H)	37.27	99.1	1.50	70 (77)	1.50	4	0.95	0.0514	69	
LSRPM 160 MP			074-00660A (N)			1.13		1.13					
LSRPM 160 MP			074-00770A (N)			1.34		77					1.34
LSRPM 160 MP			074-01000A (H)			1.50		1.50					
LSRPM 160 LR	49	95.5	074-01000A (H)	47.38	125.7	1.50	88 (91)	1.50	4	0.95	0.0626	79	
LSRPM 160 LR			074-00770A (N)			1.14		91					1.14
LSRPM 160 LR			074-01000A (N)			1.35		1.35					
LSRPM 200 L	50	95.5	074-01000A (H)	45.36	120.7	1.35	88 (97)	1.45	4	0.95	0.13	135	
LSRPM 200 L			074-01000A (N)			1.18		97					1.27
LSRPM 200 L	074-01340A (N)	1.35	1.45										
LSRPM 200 L1	70	96	084-01340A (H)	70	186	1.35	130	1.45	4	0.96	0.17	153	
LSRPM 200 L1	85	96.4	084-01570A (H)	76.93	203.6	1.35	143 (158)	1.45	4	0.96	0.22	178	
LSRPM 200 L1			084-01570A (N)			1.19		158					1.28

(1) N = Normal duty
H = Heavy duty

(2) Motor and drive maximum torque / Motor rated torque

(3) Motor and drive rated current. If the motor rated current is higher, the value is mentioned between the brackets. The motor rated current must be set at parameter 00.046 {05.007}.

(4) Motor and drive maximum current / Motor rated current. This value must be set at parameter 00.006 {04.007}.

(5) Minimum switching frequency. This value must be set at parameter 00.041 {05.018}. The « disable auto switching frequency change » parameter {05.035} must be set to ON.

DYNEO® VARIABLE SPEED DRIVES

Unidrive M variable speed drives/LSRPM permanent magnet synchronous motors Selection

3000 range

Class F - DT80K - S1 Self-Cooled - Altitude 1000 m max - Ambient temperature 40°C max

Power supply upstream from the drive 400 V (in accordance with IEC 60034-1)

15.3	Drive limit
16.2	Motor limit

MOTOR			DRIVE	VARIABLE SPEED MOTOR							MOTOR	
Type	Rated power P_n kW	Efficiency IEC 60034-2-1 2007 η 4/4	Type Unidrive M 600/700/800 (1)	Available power P_n kW	Rated torque M_n N.m	Maximum torque/ Rated torque M_m/M_n (2)	Rated current I_n A (3)	Maximum current/ Rated current I_m/I_n (4)	Minimum switching frequency F_D kHz (5)	Efficiency η 4/4	Moment of inertia J kg.m ²	Weight IM B3 kg
LSRPM 90 SL	5.8	91.5	034-00100A (N)	5.8	19	1.23	11	1.23	4	0.91	0.0032	14
LSRPM 90 L	7.3	93	044-00150A (H)	7.3	23	1.50	13.5	1.50	4	0.93	0.0051	17
LSRPM 100 L			044-00150A (H)	8.06	25.9	1.50	15 (16.2)	1.50				
LSRPM 100 L	8.7	93	044-00150A (N)	8.7	28	1.25	16.2	1.25	4	0.93	0.006	19
LSRPM 100 L			044-00172A (H)			1.50		1.50				
LSRPM 100 L			044-00172A (H)	9.33	29.3	1.50	17.2 (18.8)	1.50				
LSRPM 100 L	10.2	93.5	044-00172A (N)	10.2	32	1.40	18.8	1.40	4	0.93	0.0078	24
LSRPM 100 L			054-00270A (H)			1.50		1.50				
LSRPM 100 L	11.6	93.5	044-00172A (N)	11.6	37	1.26	21	1.26	4	0.93	0.009	26
LSRPM 100 L			054-00270A (H)			1.50		1.50				
LSRPM 132 M			054-00300A (H)	14.69	46.5	1.50	27.9 (30)	1.50				
LSRPM 132 M	15.8	93	054-00270A (N)			1.10		1.10	4	0.93	0.0165	40
LSRPM 132 M			054-00300A (N)	15.8	50	1.14	30	1.14				
LSRPM 132 M			064-00350A (H)			1.50		1.50				
LSRPM 132 M			064-00350A (H)	18.14	58	1.50	35 (38)	1.50				
LSRPM 132 M	19.7	93.5	064-00350A (N)	19.7	63	1.10	38	1.10	4	0.93	0.0231	44
LSRPM 132 M			064-00420A (H)			1.50		1.50				
LSRPM 132 M			064-00420A (H)	21.95	70.6	1.50	42 (44)	1.50				
LSRPM 132 M	23	94	064-00470A (H)			1.20		1.20	4	0.94	0.0311	49
LSRPM 132 M			064-00420A (N)	23	74	1.50	44	1.50				
LSRPM 132 M			064-00470A (N)			1.50		1.50				
LSRPM 160 MP	30	94.5	064-00470A (N)	30	96	1.22	57	1.22	4	0.94	0.0418	60
LSRPM 160 MP			074-00660A (H)			1.50		1.50				
LSRPM 160 MP			074-00660A (H)	35.91	114.5	1.50	66 (68)	1.50				
LSRPM 160 MP	37	95	074-00660A (N)	37	118	1.28	68	1.28	4	0.95	0.0514	69
LSRPM 160 MP			074-00770A (H)			1.50		1.50				
LSRPM 160 LR	44	95	074-00770A (N)	44	140	1.26	82	1.26	4	0.95	0.0626	79
LSRPM 160 LR			074-01000A (H)			1.50		1.50				
LSRPM 200 L	50	95.5	084-01340A (H)	50	159	1.35	112	1.45	4	0.95	0.13	135
LSRPM 200 L1	65	96	084-01340A (H)	65	207	1.35	126	1.45	4	0.96	0.17	153
LSRPM 200 L1	85	96.5	084-01570A (N)	85	271	1.11	170	1.19	4	0.96	0.22	178

(1) N = Normal duty
H = Heavy duty

(2) Motor and drive maximum torque / Motor rated torque

(3) Motor and drive rated current. If the motor rated current is higher, the value is mentioned between the brackets. The motor rated current must be set at parameter 00.046 {05.007}.

(4) Motor and drive maximum current / Motor rated current. This value must be set at parameter 00.006 {04.007}.

(5) Minimum switching frequency. This value must be set at parameter 00.041 {05.018}. The « disable auto switching frequency change » parameter {05.035} must be set to ON.

DYNEO® VARIABLE SPEED DRIVES

Unidrive M variable speed drives/LSRPM permanent magnet synchronous motors Selection

2400 range

Class F - DT80K - S1 Self-Cooled - Altitude 1000 m max - Ambient temperature 40°C max

Power supply upstream from the drive 400 V (in accordance with IEC 60034-1)

8.8	Drive limit
9.1	Motor limit

MOTOR			DRIVE	VARIABLE SPEED MOTOR							MOTOR	
Type	Rated power	Efficiency IEC 60034-2-1 2007	Type Unidrive M 600/700/800 (1)	Available power	Rated torque	Maximum torque/ Rated torque	Rated current	Maximum current/ Rated current	Minimum switching frequency	Efficiency	Moment of inertia	Weight
	P _n kW	η 4/4		P _n kW	M _n N.m	M _m /M _n (2)	I _n A (3)	I _m /I _n (4)	F _D kHz (5)	η 4/4	J kg.m ²	IM B3 kg
LSRPM 90 SL	4.8	90.5	034-00078A (N)	4.8	19	1.26	9.1	1.25	4	0.9	0.0032	14
LSRPM 90 SL			034-00100A (H)			1.50		1.49				
LSRPM 90 L	6	91.5	034-00100A (N)	6	24	1.24	10.9	1.24	4	0.91	0.0051	17
LSRPM 100 L	7.2	92	044-00150A (H)	7.2	29	1.50	13	1.50	4	0.92	0.006	19
LSRPM 100 L	8.4	92.5	044-00150A (H)	8.29	32.6	1.50	15 (15.2)	1.50	4	0.92	0.0078	24
LSRPM 100 L			044-00150A (N)	8.4	33	1.34	15.2	1.34				
LSRPM 100 L			044-00172A (H)	1.50	1.50							
LSRPM 100 L	9.5	93	044-00172A (H)	9.23	36.9	1.50	17.2 (17.7)	1.50	4	0.93	0.009	26
LSRPM 100 L			044-00150A (N)	9.5	38	1.15	17.7	1.15				
LSRPM 100 L	13.1	92.5	044-00172A (N)	9.5	38	1.50	17.7	1.49	4	0.93	0.009	26
LSRPM 132 M			054-00270A (H)	12.42	49.3	1.50	23.7 (25)	1.50				
LSRPM 132 M	13.1	92.5	054-00270A (N)	13.1	52	1.32	25	1.32	4	0.92	0.0165	40
LSRPM 132 M			054-00300A (H)	1.50	1.50							
LSRPM 132 M			054-00300A (H)	14.67	58.5	1.50	27.9 (31)	1.50				
LSRPM 132 M	16.3	93	054-00300A (N)	16.3	65	1.10	31	1.10	4	0.93	0.0231	44
LSRPM 132 M			064-00350A (H)	1.50	1.50							
LSRPM 132 M	19.2	93.5	064-00350A (H)	18.16	71.9	1.50	35 (37)	1.50	4	0.93	0.0311	49
LSRPM 132 M			064-00350A (N)	19.2	76	1.13	37	1.13				
LSRPM 132 M			064-00420A (H)	1.50	1.50							
LSRPM 160 MP	25	94	064-00420A (H)	22.34	88.5	1.50	42 (47)	1.50	4	0.94	0.0418	60
LSRPM 160 MP			064-00470A (H)	1.12	47	1.12						
LSRPM 160 MP			064-00420A (N)	25	99	1.47	1.47					
LSRPM 160 MP			064-00470A (N)	1.47	1.47							
LSRPM 160 MP	31	94.5	064-00470A (N)	30.47	119.9	1.20	57 (58)	1.19	4	0.94	0.0514	69
LSRPM 160 MP			074-00660A (H)	31	122	1.50	58	1.50				
LSRPM 160 LR	36	94.5	074-00660A (H)	34.94	140.7	1.50	66 (68)	1.50	4	0.94	0.0626	79
LSRPM 160 LR			074-00660A (N)	36	145	1.28	68	1.28				
LSRPM 160 LR			074-00770A (H)	1.50	1.50							
LSRPM 200 L	37.5	95	074-00770A (H)	32.41	128.8	1.35	70 (81)	1.45	4	0.95	0.13	135
LSRPM 200 L			074-00770A (N)	37.5	149	1.19	81	1.28				
LSRPM 200 L			074-01000A (H)	1.35	1.45							
LSRPM 200 L	50	95.4	084-01340A (H)	50	199	1.35	110	1.45	4	0.95	0.17	150
LSRPM 200 L1	65	95.9	084-01340A (H)	61.68	245.8	1.35	130 (137)	1.45	4	0.96	0.2	168
LSRPM 200 L1			084-01340A (N)	65	259	1.16	137	1.24				
LSRPM 200 L1			084-01570A (H)	1.35	1.45							
LSRPM 200 L1	80	96.6	084-01570A (H)	71.5	284.2	1.35	143 (160)	1.45	4	0.97	0.24	183
LSRPM 200 L1			084-01570A (N)	80	318	1.18	160	1.27				

(1) N = Normal duty
H = Heavy duty

(2) Motor and drive maximum torque / Motor rated torque

(3) Motor and drive rated current. If the motor rated current is higher, the value is mentioned between the brackets. The motor rated current must be set at parameter 00.046 {05.007}.

(4) Motor and drive maximum current / Motor rated current. This value must be set at parameter 00.006 {04.007}.

(5) Minimum switching frequency. This value must be set at parameter 00.041 {05.018}. The « disable auto switching frequency change » parameter {05.035} must be set to ON.

DYNEO® VARIABLE SPEED DRIVES

Unidrive M variable speed drives/LSRPM permanent magnet synchronous motors Selection

1800 range

Class F - DT80K - S1 Self-Cooled - Altitude 1000 m max - Ambient temperature 40°C max

Power supply upstream from the drive 400 V (in accordance with IEC 60034-1)

8.8	Drive limit
10.2	Motor limit

MOTOR			DRIVE	VARIABLE SPEED MOTOR							MOTOR	
Type	Rated power P_n kW	Efficiency IEC 60034-2-1 2007 η 4/4	Type Unidrive M 600/700/800 (1)	Available power P_n kW	Rated torque M_n N.m	Maximum torque/ Rated torque M_m/M_n (2)	Rated current I_n A (3)	Maximum current/ Rated current I_m/I_n (4)	Minimum switching frequency F_D kHz (5)	Efficiency η 4/4	Moment of inertia J kg.m ²	Weight IM B3 kg
LSRPM 90 SL			034-00062A (H)	3.23	17.1	1.50	6.2 (6.9)	1.51				
LSRPM 90 SL	3.6	89	034-00062A (N)	3.6	19	1.22	6.9	1.22	3	0.89	0.0032	14
LSRPM 90 SL			034-00078A (H)			1.50		1.51				
LSRPM 90 L			034-00078A (H)	4.13	22	1.50	7.8 (8.5)	1.51				
LSRPM 90 L	4.5	90.5	034-00078A (N)	4.5	24	1.35	8.5	1.34	3	0.9	0.0051	17
LSRPM 90 L			034-00100A (H)			1.50		1.51				
LSRPM 100 L			034-00100A (H)	5.29	28.4	1.50	10 (10.2)	1.50				
LSRPM 100 L	5.4	91	034-00078A (N)	5.4	29	1.12	10.2	1.12	3	0.91	0.006	19
LSRPM 100 L			034-00100A (N)			1.33		1.32				
LSRPM 100 L			034-00100A (N)	6.3	33	1.15		1.14				
LSRPM 100 L	6.3	91.5	044-00150A (H)	6.3	33	1.50	11.8	1.50	3	0.91	0.0078	24
LSRPM 100 L			044-00150A (H)	7.2	38	1.50	13.4	1.50	3	0.92	0.009	26
LSRPM 100 L	7.2	92	044-00172A (H)	8.87	47.1	1.50	17.2 (19)	1.50	3	0.92	0.0165	40
LSRPM 132 M	9.8	92	044-00172A (N)	9.8	52	1.39	19	1.39				
LSRPM 132 M			044-00172A (N)			1.10		1.10				
LSRPM 132 M			054-00270A (N)	12.3	65	1.38	24	1.38	3	0.92	0.0231	44
LSRPM 132 M	12.3	92.5	054-00300A (N)			1.42		1.42				
LSRPM 132 M			054-00270A (H)			1.50		1.50				
LSRPM 132 M			054-00270A (H)	13.06	68.9	1.50	25.4 (28)	1.50				
LSRPM 132 M	14.4	93	054-00270A (N)	14.4	76	1.18	28	1.18	3	0.93	0.0311	49
LSRPM 132 M			054-00300A (H)			1.50		1.50				
LSRPM 160 MP			064-00350A (H)	18.18	96.2	1.50	35 (36)	1.50				
LSRPM 160 MP	18.7	93.5	064-00350A (N)	18.7	99	1.16	36	1.16	3	0.93	0.0418	60
LSRPM 160 MP			064-00420A (H)			1.50		1.50				
LSRPM 160 MP			064-00420A (H)	22.47	119.2	1.50	42 (43)	1.50				
LSRPM 160 MP	23	94	064-00420A (N)	23	122	1.23	43	1.23	3	0.94	0.0514	69
LSRPM 160 MP			064-00470A (H)			1.50		1.50				
LSRPM 160 LR			064-00470A (H)	24.15	128.3	1.50	46 (52)	1.50				
LSRPM 160 LR	27.3	94	064-00470A (N)	27.3	145	1.33	52	1.33	3	0.94	0.0626	79
LSRPM 160 LR			074-00660A (H)			1.50		1.50				
LSRPM 200 L			074-00770A (H)	32.16	170.6	1.35	77 (79)	1.45				
LSRPM 200 L	33	94	074-00770A (N)	33	175	1.22	79	1.31	3	0.94	0.13	135
LSRPM 200 L			074-01000A (H)			1.35		1.45				
LSRPM 200 L			074-00770A (H)	37.33	197.9	1.35	77 (82.5)	1.45				
LSRPM 200 L	40	94.8	074-00770A (N)	40	212	1.17	82.5	1.25	3	0.95	0.17	150
LSRPM 200 L			074-01000A (H)			1.35		1.45				
LSRPM 200 L			074-01000A (H)	47.83	253.9	1.35	100 (115)	1.45	3	0.96	0.2	165
LSRPM 200 L	55	95.7	084-01340A (H)	55	292	1.35	115	1.45				
LSRPM 225 ST1			084-01340A (H)	65.59	347.7	1.35	134 (143)	1.45				
LSRPM 225 ST1	70	96.1	084-01340A (N)	70	371	1.11	143	1.19	3	0.96	0.26	193
LSRPM 225 ST1			084-01570A (H)			1.35		1.45				
LSRPM 225 MR1			084-01570A (H)	77.59	411.7	1.35	157 (172)	1.45				
LSRPM 225 MR1	85	96	084-01570A (N)	85	451	1.10	172	1.18	3	0.96	0.32	223

(1) N = Normal duty
H = Heavy duty

(2) Motor and drive maximum torque / Motor rated torque

(3) Motor and drive rated current. If the motor rated current is higher, the value is mentioned between the brackets. The motor rated current must be set at parameter 00.046 {05.007}.

(4) Motor and drive maximum current / Motor rated current. This value must be set at parameter 00.006 {04.007}.

(5) Minimum switching frequency. This value must be set at parameter 00.041 {05.018}. The « disable auto switching frequency change » parameter {05.035} must be set to ON.

DYNEO® VARIABLE SPEED DRIVES

Unidrive M variable speed drives/LSRPM permanent magnet synchronous motors Selection

1500 range

Class F - DT80K - S1 Self-Cooled - Altitude 1000 m max - Ambient temperature 40°C max

Power supply upstream from the drive 400 V (in accordance with IEC 60034-1)

15.3	Drive limit
16	Motor limit

MOTOR			DRIVE	VARIABLE SPEED MOTOR								MOTOR	
Type	Rated power P_n kW	Efficiency IEC 60034-2-1 2007 η 4/4	Type Unidrive M 600/700/800 (1)	Available power P_n kW	Rated torque M_n N.m	Maximum torque/ Rated torque M_m/M_n (2)	Rated current I_n A (3)	Maximum current/ Rated current I_m/I_n (4)	Minimum switching frequency F_D kHz (5)	Efficiency η 4/4	Moment of inertia J kg.m ²	Weight IM B3 kg	
LSRPM 90 SL	3	87	034-00045A (N)	3	19	1.15	5.9	1.15	3	0.87	0.0032	14	
LSRPM 90 SL			034-00062A (H)			1.50		1.49					
LSRPM 90 L	3.7	89	034-00062A (H)	3.7	24	1.50	7.2 (7.2)	1.50	3	0.89	0.0051	17	
LSRPM 90 L			034-00062A (N)			1.17		1.17					
LSRPM 90 L			034-00078A (H)			1.50		1.50					
LSRPM 100 L	4.5	90	034-00078A (H)	4.5	29	1.50	7.8 (8.6)	1.50	3	0.9	0.006	19	
LSRPM 100 L			034-00078A (N)			1.33		1.33					
LSRPM 100 L			034-00100A (H)			1.50		1.50					
LSRPM 100 L			034-00078A (N)			1.15		1.15					
LSRPM 100 L	5.2	91	034-00100A (H)	5.2	33	1.50	9.9	1.49	3	0.91	0.0078	24	
LSRPM 100 L			034-00100A (N)			1.50		1.50					
LSRPM 100 L	6	91.5	034-00100A (H)	6	38	1.50	10 (10.9)	1.50	3	0.91	0.009	26	
LSRPM 100 L			034-00100A (N)			1.24		1.24					
LSRPM 132 M	8.2	91	044-00150A (H)	8.2	52	1.50	15 (16)	1.50	3	0.91	0.0165	40	
LSRPM 132 M			044-00150A (N)			1.27		1.27					
LSRPM 132 M			044-00172A (H)			1.50		1.50					
LSRPM 132 M			044-00172A (H)			8.82		56.2					1.50
LSRPM 132 M	10.2	91.5	044-00172A (N)	10.2	65	1.33	19.9	1.33	3	0.91	0.0231	44	
LSRPM 132 M			054-00270A (H)			1.50		1.50					
LSRPM 132 M	12	92	044-00172A (N)	12	76	1.15	23	1.15	3	0.92	0.0311	49	
LSRPM 132 M			054-00270A (H)			1.50		1.50					
LSRPM 160 MP	15.6	92.5	054-00270A (N)	15.6	99	1.10	30	1.10	3	0.92	0.0418	60	
LSRPM 160 MP			054-00300A (N)			1.14		1.14					
LSRPM 160 MP			064-00350A (N)			1.39		1.39					
LSRPM 160 MP			054-00300A (H)			1.50		1.50					
LSRPM 160 MP	19.2	93	064-00350A (H)	19.2	122	1.50	35 (37)	1.50	3	0.93	0.0514	69	
LSRPM 160 MP			064-00350A (N)			1.13		1.13					
LSRPM 160 MP			064-00420A (H)			1.50		1.50					
LSRPM 160 LR	22.8	93.5	064-00420A (H)	22.8	145	1.50	42 (43)	1.50	3	0.93	0.0626	79	
LSRPM 160 LR			064-00420A (N)			1.23		1.23					
LSRPM 160 LR			064-00470A (H)			1.50		1.50					
LSRPM 200 L	25	94	064-00470A (N)	25	159	1.15	56	1.24	3	0.94	0.13	135	
LSRPM 200 L			074-00660A (H)			1.35		1.45					
LSRPM 200 L	33	94.6	074-00660A (H)	29.04	184.8	1.35	66 (75)	1.45	3	0.94	0.17	150	
LSRPM 200 L			074-00770A (H)			33		210					75
LSRPM 200 L			074-00770A (H)			37.11		236.6					1.35
LSRPM 200 L	40	95.2	074-00770A (N)	40	255	1.16	83	1.25	3	0.95	0.2	165	
LSRPM 200 L			074-01000A (H)			1.35		1.45					
LSRPM 200 LU	55	95.5	074-01000A (H)	50	318.2	1.35	100 (110)	1.45	3	0.95	0.26	190	
LSRPM 200 LU			084-01340A (H)			55		350					110
LSRPM 225 MR1	70	95.7	084-01340A (N)	70	446	1.12	142	1.20	3	0.96	0.32	223	
LSRPM 225 MR1			084-01570A (H)			1.35		1.45					
LSRPM 250 ME	85	95.6	084-01570A (H)	76.26	485.4	1.35	157 (175)	1.45	3	0.96	0.65	285	

(1) N = Normal duty
H = Heavy duty

(2) Motor and drive maximum torque / Motor rated torque

(3) Motor and drive rated current. If the motor rated current is higher, the value is mentioned between the brackets. The motor rated current must be set at parameter 00.046 {05.007}.

(4) Motor and drive maximum current / Motor rated current. This value must be set at parameter 00.006 {04.007}.

(5) Minimum switching frequency. This value must be set at parameter 00.041 {05.018}. The « disable auto switching frequency change » parameter {05.035} must be set to ON.

DYNEO® VARIABLE SPEED DRIVES

Unidrive M variable speed drives/LSRPM permanent magnet synchronous motors Selection

900 range

Class F - DT80K - S1 Self-Cooled - Altitude 1000 m max - Ambient temperature 40°C max

Power supply upstream from the drive 400 V (in accordance with IEC 60034-1)

12.1	Drive limit
18.9	Motor limit

MOTOR			DRIVE	VARIABLE SPEED MOTOR								MOTOR	
Type	Rated power P _n kW	Efficiency IEC 60034-2-1 2007 η 4/4	Type Unidrive M 600/700/800 (1)	Available power P _n kW	Rated torque M _n N.m	Maximum torque/ Rated torque M _m /M _n (2)	Rated current I _n A (3)	Maximum current/ Rated current I _m /I _n (4)	Minimum switching frequency F _D kHz (5)	Efficiency η 4/4	Moment of inertia J kg.m ²	Weight IM B3 kg	
LSRPM 90 SL	1.8	82	034-00031A (N)	1.8	19	1.29	3.8	1.29	3	0.82	0.0032	14	
LSRPM 90 SL			034-00045A (H)			1.50		1.50					
LSRPM 90 L	2.2	84	034-00045A (H)	2.15	23.5	1.50	4.5 (4.6)	1.50	3	0.84	0.0051	17	
LSRPM 100 L			034-00045A (N)			1.26		1.26					
LSRPM 100 L	2.7	85	034-00062A (H)	2.7	29	1.50	5.4	1.50	3	0.85	0.006	19	
LSRPM 100 L			034-00045A (N)			1.10		1.10					
LSRPM 100 L	3.1	87	034-00062A (H)	3.1	33	1.50	6.2	1.50	3	0.87	0.0078	24	
LSRPM 100 L			034-00062A (H)			1.50		1.51					
LSRPM 100 L			034-00062A (N)			1.22		1.22					
LSRPM 100 L	3.6	88	034-00078A (H)	3.6	38	1.50	6.9	1.51	3	0.88	0.009	26	
LSRPM 132 M			034-00078A (N)			1.16		1.15					
LSRPM 132 M	4.9	88	034-00100A (H)	4.9	52	1.50	9.9	1.49	3	0.88	0.0165	40	
LSRPM 132 M			034-00100A (N)			1.10		1.10					
LSRPM 132 M	6.1	89	044-00150A (H)	6.1	65	1.50	12.3	1.50	3	0.89	0.0231	44	
LSRPM 132 M			044-00150A (H)			1.50		1.50					
LSRPM 132 M	7.2	90	044-00150A (H)	7.2	76	1.50	14.3	1.50	3	0.9	0.0311	49	
LSRPM 160 MP			044-00172A (H)			1.50	17.2 (18.4)	1.50					
LSRPM 160 MP	9.4	90.5	044-00150A (N)	9.4	99	1.10	18.4	1.10	3	0.9	0.0418	60	
LSRPM 160 MP			044-00172A (N)			1.43		1.43					
LSRPM 160 MP			044-00172A (N)			1.15		1.15					
LSRPM 160 MP	11.5	91	054-00270A (H)	11.5	122	1.50	23	1.50	3	0.91	0.0514	69	
LSRPM 160 LR			054-00270A (H)			1.50	25.4 (27)	1.50					
LSRPM 160 LR	13.7	91	054-00270A (N)	13.7	145	1.22	27	1.22	3	0.91	0.0626	79	
LSRPM 160 LR			054-00300A (H)			1.50		1.50					
LSRPM 200 L			064-00350A (H)			1.35	35 (38)	1.45					
LSRPM 200 L	15	90.6	064-00420A (H)	15	159	1.35	38	1.45	3	0.9	0.13	135	
LSRPM 200 L			064-00420A (H)			1.35	42 (43)	1.45					
LSRPM 200 L			064-00420A (N)			1.14		1.23					
LSRPM 200 L	20	91.6	064-00470A (H)	20	212	1.35	43	1.45	3	0.91	0.17	150	
LSRPM 200 L			064-00470A (H)			1.35	46 (52)	1.45					
LSRPM 200 L			064-00470A (H)			1.24		1.33					
LSRPM 200 L	25	92.3	064-00470A (N)	25	265	1.35	52	1.45	3	0.92	0.2	165	
LSRPM 200 L			074-00660A (H)			1.35		1.45					
LSRPM 200 LU			074-00660A (H)			1.35	66 (70)	1.45					
LSRPM 200 LU	33	92.9	074-00660A (N)	33	350	1.16	70	1.24	3	0.93	0.26	190	
LSRPM 200 LU			074-00770A (H)			1.35		1.45					
LSRPM 250 SE			074-00770A (H)			1.35	77 (79)	1.45					
LSRPM 250 SE	40	95.5	074-00770A (N)	40	424	1.22	79	1.31	3	0.95	0.54	250	
LSRPM 250 SE			074-01000A (H)			1.35		1.45					
LSRPM 250 ME	50	95.8	074-01000A (H)	50	531	1.35	98	1.45	3	0.96	0.65	285	
LSRPM 280 SD	60	96.2	084-01340A (H)	60	637	1.35	120	1.45	3	0.96	0.92	350	
LSRPM 280 SD			084-01340A (H)			1.35	134 (140)	1.45					
LSRPM 280 SD	75	96	084-01340A (N)	75	796	1.13	140	1.22	3	0.96	1	380	
LSRPM 280 SD			084-01570A (H)			1.35		1.45					
LSRPM 280 MK1			084-01570A (H)			1.35	157 (170)	1.45					
LSRPM 280 MK1	85	95.9	084-01570A (N)	85	902	1.11	170	1.19	3	0.96	1.67	545	

(1) N = Normal duty
H = Heavy duty

(2) Motor and drive maximum torque / Motor rated torque

(3) Motor and drive rated current. If the motor rated current is higher, the value is mentioned between the brackets. The motor rated current must be set at parameter 00.046 {05.007}.

(4) Motor and drive maximum current / Motor rated current. This value must be set at parameter 00.006 {04.007}.

(5) Minimum switching frequency. This value must be set at parameter 00.041 {05.018}. The « disable auto switching frequency change » parameter {05.035} must be set to ON.

DYNEO® VARIABLE SPEED DRIVES

Unidrive M variable speed drives/LSRPM permanent magnet synchronous motors Selection

750 range

Class F - DT80K - S1 Self-Cooled - Altitude 1000 m max - Ambient temperature 40°C max

Power supply upstream from the drive 400 V (in accordance with IEC 60034-1)

12.1	Drive limit
18.9	Motor limit

MOTOR			DRIVE	VARIABLE SPEED MOTOR								MOTOR	
Type	Rated power P _n kW	Efficiency IEC 60034-2-1 2007 η 4/4	Type Unidrive M 600/700/800 (1)	Available power P _n kW	Rated torque M _n N.m	Maximum torque/ Rated torque M _m /M _n (2)	Rated current I _n A (3)	Maximum current/ Rated current I _m /I _n (4)	Minimum switching frequency F _D kHz (5)	Efficiency η 4/4	Moment of inertia J kg.m ²	Weight IM B3 kg	
LSRPM 90 SL	1.4	80	034-00025A (N)	1.4	18	1.24	3	1.23	3	0.8	0.0032	14	
LSRPM 90 SL			034-00031A (H)			1.50		1.50					
LSRPM 90 L	1.8	83	034-00031A (N)	1.8	23	1.33	3.7	1.32	3	0.83	0.0051	17	
LSRPM 90 L			034-00045A (H)			1.50		1.51					
LSRPM 100 L	2.1	84	034-00031A (N)	2.1	27	1.11	4.4	1.11	3	0.84	0.0066	19	
LSRPM 100 L			034-00045A (H)			1.50		1.50					
LSRPM 100 L	2.5	85	034-00045A (H)	2.3	28.8	1.50	4.5 (5)	1.50	3	0.85	0.0078	24	
LSRPM 100 L			034-00045A (N)	2.5	32	1.36	5	1.36					
LSRPM 100 L	2.8	86	034-00062A (H)	2.8	36	1.50	5.7	1.50	3	0.86	0.009	26	
LSRPM 100 L			034-00045A (N)			2.8		36					1.19
LSRPM 100 L	2.8	86	034-00062A (H)	2.8	36	1.50	5.7	1.51	3	0.86	0.009	26	
LSRPM 100 L			034-00062A (N)			2.8		36					1.19
LSRPM 132 M	4.1	86	034-00078A (H)	3.8	47.7	1.50	7.8 (8.5)	1.51	3	0.86	0.0165	40	
LSRPM 132 M			034-00078A (N)	4.1	52	1.35	8.5	1.34					
LSRPM 132 M	5.1	87	034-00100A (H)	4.9	61.9	1.50	10 (10.5)	1.50	3	0.87	0.0231	44	
LSRPM 132 M			034-00100A (N)			5.1	65	1.29					10.5
LSRPM 132 M	6	88	034-00150A (N)	6.0	76	1.11	12.2	1.11	3	0.88	0.0311	49	
LSRPM 132 M			044-00150A (H)			6.0		76					1.50
LSRPM 160 MP	7.8	89	044-00150A (H)	7.5	95.2	1.50	15 (15.6)	1.50	3	0.89	0.0418	60	
LSRPM 160 MP			044-00150A (N)	7.8	99	1.30	15.6	1.30					
LSRPM 160 MP	9.6	90	044-00172A (H)	8.7	110.4	1.50	17.2 (19)	1.50	3	0.9	0.0514	69	
LSRPM 160 MP			044-00172A (N)			9.6	122	1.39					19
LSRPM 160 MP	11.4	90.5	054-00270A (N)	11.4	145	1.50	21	1.50	3	0.9	0.0626	79	
LSRPM 160 MP			044-00172A (H)			11.4		145					1.26
LSRPM 160 LR	12.5	89.5	054-00270A (H)	11.7	149.1	1.35	30 (32)	1.45	3	0.89	0.13	135	
LSRPM 160 LR			064-00350A (H)			12.5	159	1.35					32
LSRPM 200 L	16.5	90.8	064-00350A (H)	16.5	204	1.35	35	1.45	3	0.91	0.17	150	
LSRPM 200 L			064-00420A (H)			20.1	254.9	1.35					42 (44)
LSRPM 200 L	21	91.4	064-00420A (N)	21.0	267	1.12	44	1.20	3	0.91	0.2	165	
LSRPM 200 L			064-00470A (H)			21.0		267					1.35
LSRPM 200 LU	26	92.2	064-00470A (N)	26.0	337	1.13	57	1.22	3	0.92	0.26	190	
LSRPM 200 LU			074-00660A (H)			26.0		337					1.35
LSRPM 250 SE	33	94.8	074-00660A (H)	33.0	420	1.35	65	1.45	3	0.95	0.54	250	
LSRPM 250 SE			074-00770A (H)			33.0		420					1.35
LSRPM 250 SE	40	95.3	074-00770A (N)	40.0	509	1.20	80	1.29	3	0.95	0.65	285	
LSRPM 250 SE			074-01000A (H)			40.0		509					1.35
LSRPM 280 SD	55	95.5	074-01000A (H)	51.4	654.2	1.35	100 (107)	1.45	3	0.95	0.92	350	
LSRPM 280 SD			084-01340A (H)			55.0	700	1.35					107
LSRPM 280 MD	70	95.6	084-01340A (H)	66.1	840.8	1.35	134 (142)	1.45	3	0.96	1	380	
LSRPM 280 MD			084-01340A (N)			70.0	891	1.12					142
LSRPM 280 MD	85	95.9	084-01570A (H)	78.0	993.4	1.35	157 (171)	1.45	3	0.96	2.1	625	
LSRPM 315 SP1			084-01570A (N)			85.0	1082	1.10					171

(1) N = Normal duty
H = Heavy duty

(2) Motor and drive maximum torque / Motor rated torque

(3) Motor and drive rated current. If the motor rated current is higher, the value is mentioned between the brackets. The motor rated current must be set at parameter 00.046 {05.007}.

(4) Motor and drive maximum current / Motor rated current. This value must be set at parameter 00.006 {04.007}.

(5) Minimum switching frequency. This value must be set at parameter 00.041 {05.018}. The « disable auto switching frequency change » parameter {05.035} must be set to ON.

General information

Influence of the mains supply

Each industrial power supply has its own intrinsic characteristics (short-circuit capability, voltage value and fluctuation, phase imbalance, etc) and supplies equipment some of which can distort its voltage either permanently or temporarily (notches, voltage dips, overvoltage, etc). The quality of the mains supply has an impact on the performance and reliability of electronic equipment, especially variable speed drives.

Control Techniques drives are designed to operate with a mains supply typically found on industrial sites throughout the world. However, for each installation, it is important to know the characteristics of the mains supply in order to carry out corrective measures in the event of abnormal conditions.

Transient overvoltages

There are numerous sources of overvoltages on an electrical installation:

- Connection/disconnection of banks of power factor correction capacitors
- High-power thyristor-controlled equipment (oven, DC drive, etc)
- Overhead power supply

Connection/disconnection of a bank of cos φ correction capacitors

Connecting power factor correction capacitors in parallel on the drive power supply line when the drive is running can generate transient overvoltages that are likely to trip the drive safety devices, or even damage it in extreme cases.

If banks of power factor correction capacitors are used on the power supply line, make sure that:

- The threshold between steps is low enough to avoid causing overvoltage on the line
- The capacitors are not permanently connected

Presence of commutation notches on the line

When high-power thyristor-controlled equipment is connected on the same line as the drive, it is essential to ensure that the harmonics generated by the commutation notches do not excessively distort the mains voltage and do not create voltage peaks with amplitude higher than 1.6 x mains V_{rms} . If this is the case, it is essential to take corrective measures to guarantee the mains quality.

Unbalanced power supply

In the same way as can be seen on an electric motor, the line phase voltage imbalance of a drive may have consequences on its operation. Please refer to the drive installation manual.

Equipotential bonding

The equipotential earth bonding of some industrial sites is not always observed. This lack of equipotential leads to leakage currents which flow via the earth cables (green/yellow), the machine chassis, the pipework, etc, and also via the electrical equipment. In some extreme cases, these currents can trip the drive.

It is essential that the earth network is designed and implemented by the installation supervisor so that its impedance is as low as possible, so as to distribute the fault currents and high-frequency currents without them passing through electrical equipment. Metal grounds must be mechanically connected to each other with the largest possible electrical contact area. Under no circumstances can the earth connections designed to protect people, by linking metal grounds to earth via a cable, serve as a substitute for the ground connections (see IEC 61000-5-2).

The immunity and radio-frequency emission level are directly linked to the quality of the ground connections.

Connection of control and encoder cables

WARNING: Strip back the shielding on the metal clamp collars in order to ensure 360° contact.

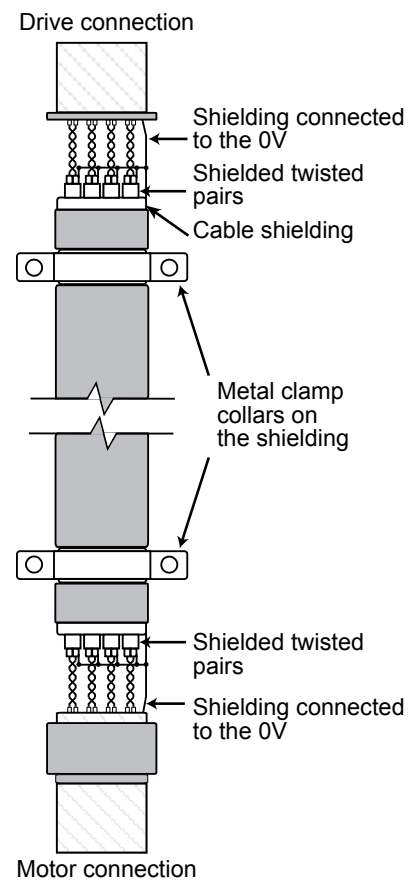

Installation

The following information is given for guidance only, and should never be used as a substitute for the current standards, nor does it relieve the installer of his responsibility. Depending on the installation, more optional elements can be added to the installation:

Switch-fuse : a padlockable breaking device must be installed to isolate the installation should operator intervention be necessary. This device must provide protection against overheating and short-circuits. The fuse rating is stated in the drive documentation. The switch-fuse can be replaced with a circuit-breaker (with appropriate breaking capacity).

RFI filter : its role is to reduce the drive electromagnetic emissions, and thus comply with EMC standards. Control Techniques drives are, as standard, equipped with an internal RFI filter. Some environments require the addition of an external filter. Please consult the drive documentation to find out the drive conformance levels, with and without an external RFI filter.

Drive power supply cables : these cables do not necessarily need shielding. Their cross-section is recommended in the drive documentation, however, it can be adapted according to the type of cable, installation method, the cable length (voltage drop), etc. See below "Sizing the power cables".

Line reactor: its role is to reduce the risk of damage to the drives following phase imbalance or significant disturbance on the electrical mains supply. The line reactor can also reduce low-frequency harmonics.

Motor power supply cables: these cables must be shielded to ensure EMC conformance of the installation. The cable shielding must be connected over 360° at both ends. At the motor end, special EMC cable glands are available as an option. The cable cross-section is recommended in the drive documentation, however, it can be adapted according to the type of cable, installation method, the cable length (voltage drop), etc. See below "Sizing the power cables".

Encoder cables: shielding the sensor cables is important due to the interferences with power cables. This cable must be laid at least 30 cm away from any power cables. See "Encoders" section.

Sizing the power cables: the drive and motor power supply cables must be sized according to the applicable standard, and according to the design current, stated in the drive documentation.

The different factors to be taken into account are:

- The installation method: in a conduit, a cable tray, suspended, etc
- The type of conductor: copper or aluminium

Once the cable cross-section has been determined, check the voltage drop at the motor terminals. A significant voltage drop results in an increase in the current and additional losses in the motor (overheating).

A motor-drive and transformer system which has been earthed in accordance with good practice will contribute significantly to reducing the voltage on the shaft and the motor casing, resulting in fewer high-frequency leakage currents. Premature breakage of bearings and auxiliary equipment, such as encoders, should also be avoided wherever possible.

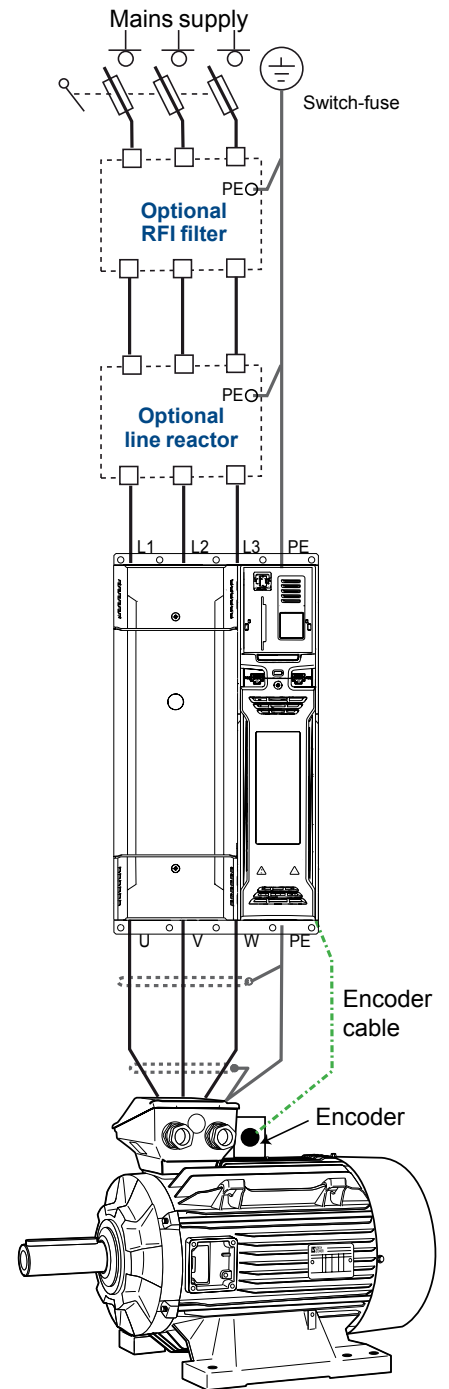

Installation

Good wiring practice

It is the responsibility of the user and/or the installer to connect the variable speed drive system in accordance with the current legislation and regulations in the country of use. This is particularly important as concerns cable size and connection of earths and grounds.

The following information is given for guidance only, and should never be used as a substitute for the current standards, nor does it relieve the installer of his responsibility. For more information, please refer to technical specification IEC 60034-25.

A variable speed drive and transformer system which have been earthed in accordance with good practice will contribute significantly to reducing the voltage on the shaft and the motor casing, resulting in fewer high-frequency leakage currents. Premature breakage of bearings and auxiliary equipment, such as encoders, should also be avoided wherever possible.

To ensure the safety of personnel, the size of the earthing cables should be determined individually in accordance with local regulations.

For compliance with standard EN 61800-3, the power conductors between drive and motor must be shielded. Use a special variable speed cable: shielded with low stray capacity and with 3 PE conductors 120° apart (diagram below). There is no need to shield the drive power supply cables.

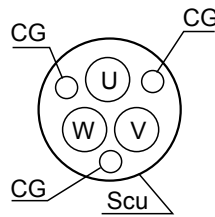

The variable speed drive wiring must be symmetrical (U,V,W at the motor end must correspond to U,V,W at the drive end) with the cable shielding earthed at both the drive end and motor end over 360°.

In the second industrial environment (if the user has an HV/LV transformer), the shielded motor power supply cable can be replaced with a 3-core + earth cable placed in a fully-enclosed metal conduit (metal cable duct for example). This metal conduit should be mechanically connected to the electrical cabinet and the structure supporting the motor. If the conduit consists of several pieces, these should be interconnected by braids to ensure earth continuity. The cables must be fixed securely at the bottom of the conduit.

The motor earth terminal (PE) must be connected directly to the drive earth terminal. A separate PE protective conductor is mandatory if the conductivity of the cable shielding is less than 50% of the conductivity of the phase conductor.

Reinforced insulation

Standard motors are compatible with power supplies with the following characteristics:

- U rms = 480 V max.
- Value of voltage peaks generated at the terminals: 1500 V max.
- Switching frequency: 2.5 kHz min.

However, they may be supplied under more severe conditions if additional protection is provided.

Reinforced winding insulation

The main effect connected with supplying power via an electronic drive is overheating of the motor due to the non-sinusoidal shape of the signal. In addition, this can result in accelerated ageing of the winding through the voltage peaks generated at each pulse in the power supply signal (see Figure 1).

For peak values greater than 1500 V, a super-insulation option for the winding is available over the entire range.

Reinforced insulation of the mechanical parts

Supplying power via a drive may affect the mechanical parts and lead to premature wear of the bearings.

This is because, in any motor, a shaft voltage exists with respect to earth. This voltage, due to electro-mechanical asymmetry, creates a potential difference between the rotor and the stator. This effect may generate electrical discharges between balls and races and lead to a reduction in bearing life.

If power is supplied via a PWM drive, a second effect is added: high frequency currents generated by the IGBT output bridges of the drives. These currents "attempt" to spread towards the drive and therefore flow through the stator and via earth where the link between casing, machine chassis and earth is correctly made.

Motors fitted with insulated bearings are specified on page 55

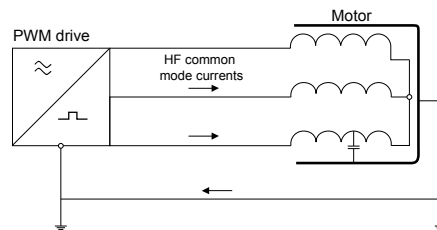
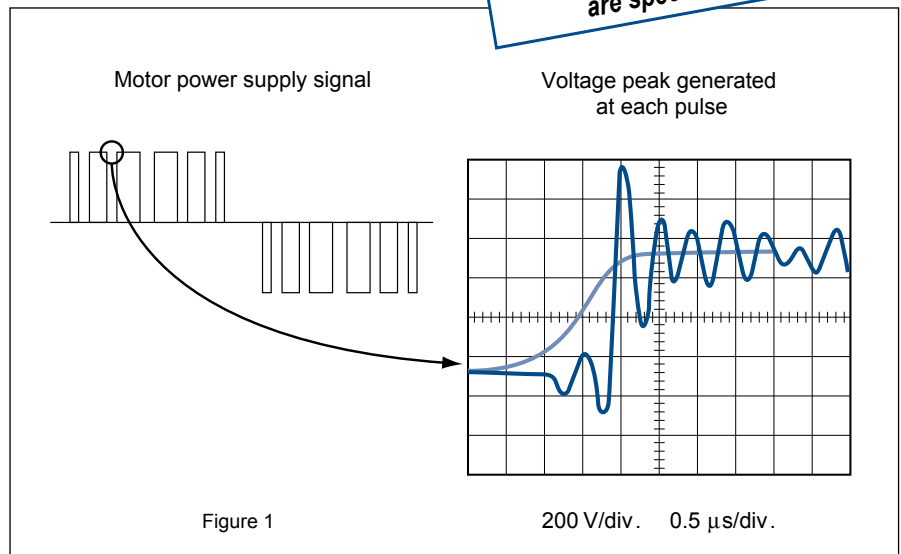

Otherwise, it will flow via the least resistive path: end shields/bearings/shaft/machine coupled to the motor. In these situations, therefore, protection for the bearings must be provided.

For this reason, an "insulated bearing" option is available over the entire range from a frame size of 200.

Insulated bearing characteristics

The outer races of the bearings are coated with a layer of electrically insulating ceramic.

The dimensions and tolerances of these bearings are identical to the standard ones used and can therefore be fitted instead, with no modifications to the motors. The breakdown voltage is 500 V.

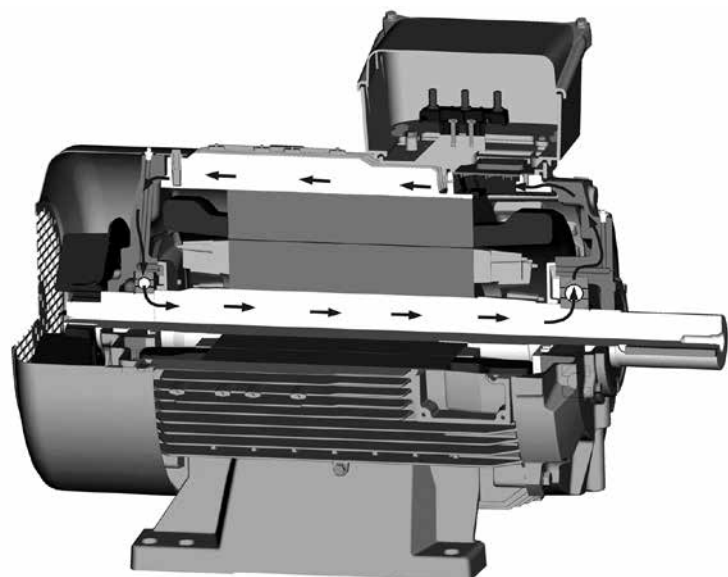

Selection of position sensor

In order to operate correctly, the Unidrive M drive must know the position of the rotor with respect to the stator at all times. For this reason, permanent magnet synchronous motors are fitted as standard with a position sensor.

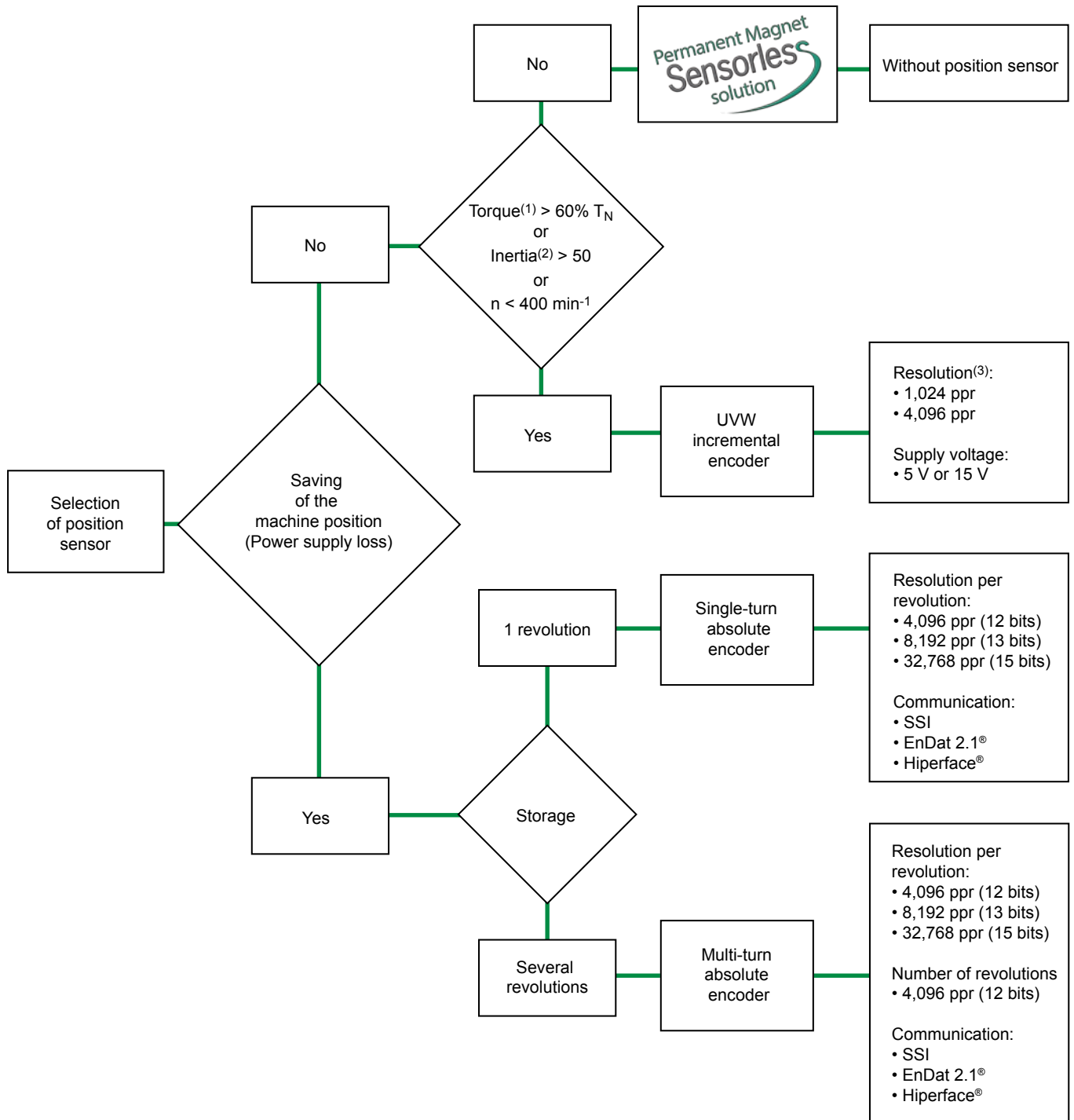

(1) Between 0 and 10% of load speed

(2) Load inertia related to the motor inertia

(3) Caution, if the speed is greater than or equal to 3000 min⁻¹, the resolution must not exceed 1,024 ppr.

Encoders

SENSORLESS mode

The Unidrive M range enables operation in sensorless mode (without encoder) in the majority of applications. In this operating mode, the rotor position feedback is calculated using the electrical measurements taken by the drive.

When operating permanent magnet synchronous machines in Sensorless mode, ensure that:

- Torque limited to 60% of T_n , between 0 and 10% of rated speed
- Inertia of the load related to the inertia of the motor < 50
- Machine rated speed > 400 min⁻¹

UVW incremental encoders

This pulse generator supplies a number of pulses on channels A,A/, B,B/, 0 marker, 0 marker/ proportional to the speed. The information on commutation channels U/V/W enables the position of the rotor to be known to within about 60° (electrical degrees).

A 1024 ppr encoder is sufficient for most applications. However, where stability at very low speed (<10 rpm) is required, use of a higher resolution encoder is recommended.

Absolute encoders

Absolute encoders save the position in the revolution and also over several revolutions, in the event of a power cut. A reference point is no longer necessary. Data is transmitted via different communication protocols (EnDat, Hiperface, SSI, etc). In some cases, SinCos or incremental data is also available.

Single-turn absolute encoders

The single-turn absolute encoder converts a rotation of the drive shaft into a series of "electrical encoded steps". The number of steps per revolution is determined by an optical disk. In general, one shaft rotation consists of 8192 steps, which corresponds to 13 bits. At the end of a complete encoder shaft revolution, the same values are repeated.

Multi-turn absolute encoders

The multi-turn absolute encoder saves the position in the revolution and also over several revolutions, with a maximum of 4096 revolutions.

Encoder - drive connecting cables

For each encoder, a specific cable, guaranteeing optimum performance of the drive connection can be proposed. Different cable finishes are possible. Please consult us.

Encoder characteristics

Encoder type	UVW INCREMENTAL ENCODERS		ABSOLUTE ENCODERS							
			Single-turn				Multi-turn (4096)			
			EnDat 2.1®	SSI		SinCos Hiperface®	EnDat 2.1®	SSI		SinCos Hiperface®
Encoder reference	KHO5	KHK5S	ECN 413	ECN 413	AFS 60	SFS60	EQN 425	EQN 425	AFM 60	SFM 60
Supply voltage	5/30 VDC	5/30 VDC	3.6/14 VDC	10/30 VDC	4.5/32 VDC	7/12 VDC	3.6/14 VDC	10/30 VDC	4.5/32 VDC	7/12 VDC
Positions per revolution	1024 or 4096	1024 or 4096	4096 max: 8192	4096 max: 8192	4096 max: 8192		4096 max: 8192	4096 max: 8192	4096 max: 8192	
Output stage	TTL (RS422)	TTL (RS422)	1 V ~	1 V ~	1 V ~	1 V ~	1 V ~	1 V ~	1 V ~	1 V ~
Max. current (no load)	140 mA	140 mA	110 mA	45 mA	30 mA	80 mA	140 mA	55 mA	30 mA	80 mA
Max. mechanical speed in continuous operation	6,000 min ⁻¹	6,000 min ⁻¹	12,000 min ⁻¹		9,000 min ⁻¹	6,000 min ⁻¹	12,000 min ⁻¹		9,000 min ⁻¹	6,000 min ⁻¹
Shaft diameter	14 mm (1)	14 mm (1)	14 mm (1)		14 mm (1)	14 mm (1)	14 mm (1)		14 mm (1)	14 mm (1)
Protection	IP65	IP67	IP64		IP65	IP65	IP64		IP65	IP65
Operating temperature	-30° +80°C	-30° +80°C	-40° +100°C		-30° +100°C	-30° +115°C	-40° +100°C		-30° +100°C	-30° +115°C
Certification	CE	CE	CE, cURus, UL/CSA		CE, cURus	CE, cURus	CE, cURus, UL/CSA		CE, cURus	CE, cURus
Type of cable to be used with it	SYBBA_	SYBBA_	SFBAA_	SFBAA_	SSBBD_	SSBBD_	SFBAA_	SFBAA_	SSBBD_	SSBBD_
Motor end finish	M23 17 pins	M23 17 pins	M23 17 pins	M23 17 pins	M23 12 pins	M23 12 pins	M23 17 pins	M23 17 pins	M23 12 pins	M23 12 pins
Drive end finish	HD15	HD15	HD15	HD15	HD15	HD15	HD15	HD15	HD15	HD15

(1) THS: Through Hollow Shaft

Resolver : consult us

Forced ventilation

To keep the rated torque over the entire speed range, forced ventilation may be necessary.

Forced ventilation characteristics for ranges up to 3600 inclusive

(please consult us for 4500 and 5500 ranges)

Motor type	FV supply voltage ¹	FV consumption		FV protection index ²
		P (W)	I (A)	
LSRPM 90 to 132	single-phase 230 or 400V	100	0.43/0.25	IP 55
LSRPM 160 to 280S	3-phase 230/400 V 50 Hz 254/460 V 60 Hz	150	0.94/0.55	IP 55
LSRPM 280M and 315	3-phase 230/400 V 50 Hz 254/460 V 60 Hz	200	1.4/0.8	IP 55

1. ± 10% for voltage, ± 2% for frequency.

2. Protection index of the forced ventilation installed on the motor.

The motors are self-cooled as standard

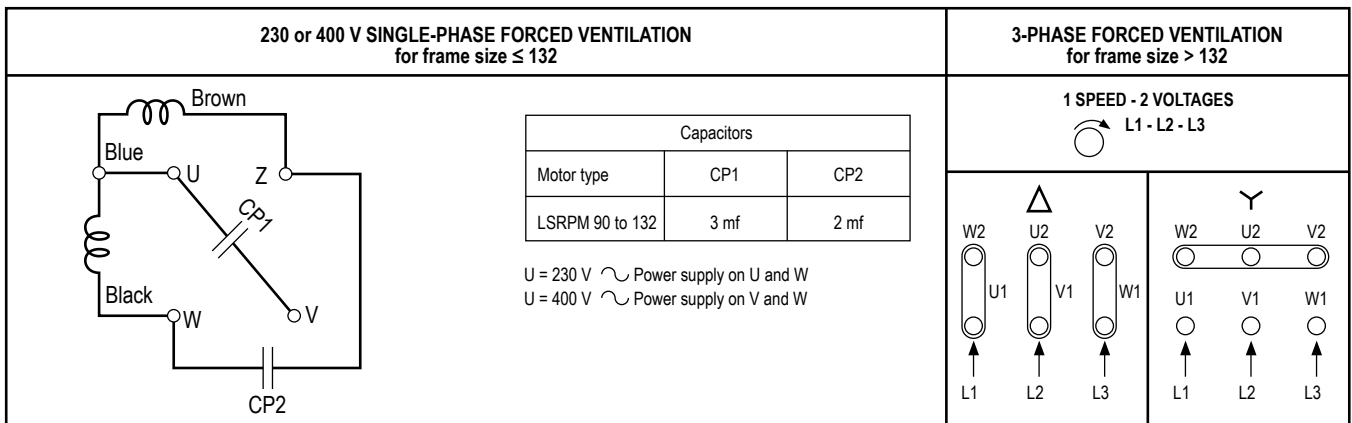

Cable glands

In certain applications, it is necessary for there to be earth continuity between the cable and the motor earth to guarantee protection of the installation in accordance

with the EMC directive, 89/336/EEC. An optional **cable gland with anchorage on shielded cable** is therefore available over the entire range.

The motors are supplied with pre-drilled and tapped terminal boxes or an undrilled mounting plate for mounting cable glands see page 56

Type and cable size of cable glands

Cable gland type	Cable size	
	Min. cable Ø (mm) W	Max. cable Ø (mm) A
ISO 16	6	11
ISO 20	7.5	13
ISO 25	12.5	18
ISO 32	17.5	25
ISO 40	24.5	33.5
ISO 50	33	43
ISO 63	42.5	55

Thermal protection

The motors are fitted with PTC sensors as standard

Motors are protected by the variable speed drive, placed between the isolating switch and the motor.
The variable speed drive provides total protection of the motor against overloads.

The motors are fitted with PTC sensors in the winding. As an option, specific thermal protection sensors can be selected from the table below.

It must be emphasized that under no circumstances can these sensors be used to carry out direct regulation of the motor operating cycles.

Fitting thermal protection

- PTO or PTF, in the control circuits.
- PTC, with relay, in the control circuits.
- PT 100 or Thermocouples, with associated reading equipment (or recorder), in the control board of the installation for continuous surveillance.

Alarm and early warning

All protective equipment can be backed up by another type of protection (with different NRTs): the first device will then act as an early warning (light or sound signals given without shutting down the power circuits), and the second device will be the alarm (shutting down the power circuits).

Built-in indirect thermal protection

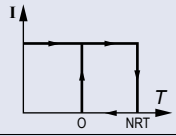
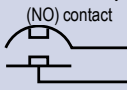
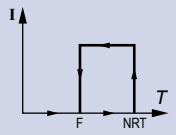
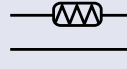
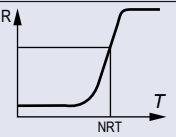
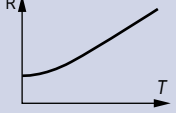
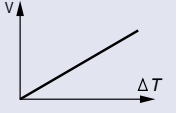
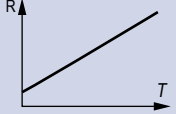
Type	Operating principle	Operating curve	Breaking capacity (A)	Protection provided	Mounting Number of devices*
Normally closed thermal protection PTO	Bimetallic strip, indirectly heated, with normally closed (NC) contact 		2.5 A at 250 V with cos φ 0.4	General monitoring for non-transient overloads	Mounting in control circuit 2 or 3 in series
Normally open thermal protection PTF	Bimetallic strip, indirectly heated, with normally open (NO) contact 		2.5 A at 250 V with cos φ 0.4	General monitoring for non-transient overloads	Mounting in control circuit 2 or 3 in parallel
Positive temperature coefficient thermistor PTC	Variable non-linear resistance with indirect heating 		0	General monitoring for transient overloads	Mounted with associated relay in control circuit 3 in series
Temperature sensor KT U	Resistance depends on the temperature of the winding		0	High accuracy continuous surveillance of key hot spots	Mounted in control boards with associated reading equipment (or recorder) 1 per hot spot
Thermocouples T (T < 150°C) Copper Constantan K (T < 1000°C) Copper-nickel	Peltier effect		0	Continuous surveillance of hot spots at regular intervals	Mounted in control boards with associated reading equipment (or recorder) 1 per hot spot
Platinum resistance thermometer PT 100	Variable linear resistor with indirect heating		0	High accuracy continuous surveillance of key hot spots	Mounted in control boards with associated reading equipment (or recorder) 1 per hot spot

- NRT: nominal running temperature.
- The NRTs are chosen according to the position of the sensor in the motor and the temperature rise class.
- Standard kTy = 84/130

* The number of devices relates to the winding protection.

DYNEO® VARIABLE SPEED DRIVES

Unidrive M variable speed drives/LSRPM permanent magnet synchronous motors
Drive dimensions

Unidrive M

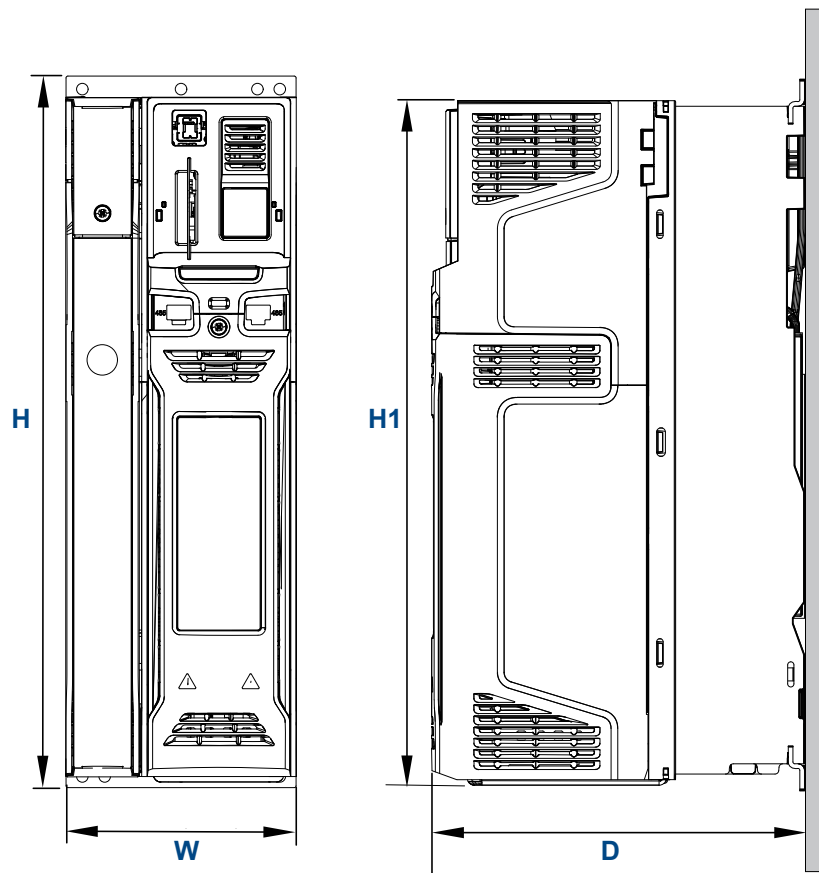

Drive type	Dimensions and weight				
	H (mm)	H1 (mm)	W (mm)	D (mm)	Weight (kg)
Unidrive M					
Frame size 03	382	365	83	200	4.5
Frame size 04	391	365	124	200	6.5
Frame size 05	391	365	143	202	7.4
Frame size 06	391	365	210	227	14
Frame size 07	557	508	270	279	28
Frame size 08	803	753	310	290	-

DYNEO® VARIABLE SPEED DRIVES

Unidrive M variable speed drives/LSRPM permanent magnet synchronous motors
Motor dimensions

Shaft extensions

Dimensions in millimetres

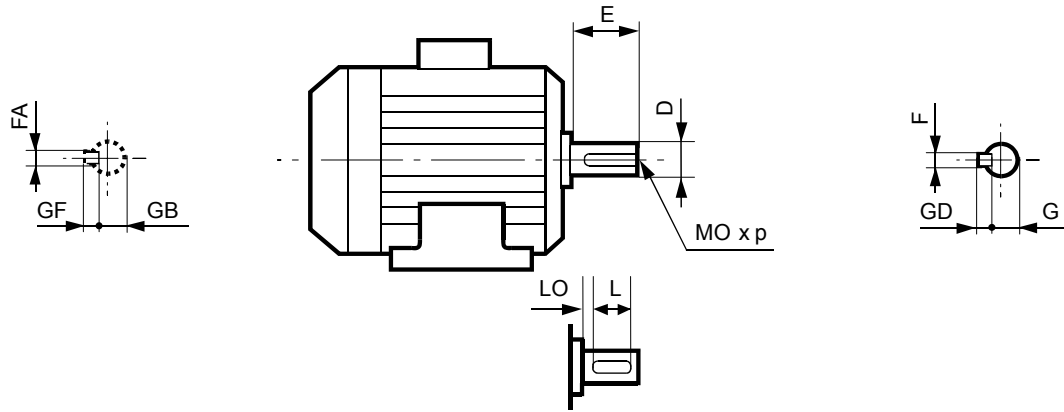

Type	Main shaft extensions																	
	375 to 1800 range									2400 to 5500 range								
	F	GD	D	G	E	O	p	L	LO	F	GD	D	G	E	O	p	L	LO
LSRPM 90 SL/L	8	7	28j6	24	60	10	22	50	6	8	7	28j6	24	60	10	22	50	6
LSRPM 100 L	10	8	32k6	27	80	12	28	63	8.5	10	8	32k6	27	80	12	28	63	8.5
LSRPM 132 M	10	8	38k6	33	80	12	28	63	7	10	8	38k6	33	80	12	28	63	7
LSRPM 160 MP/LR	14	9	48k6	42.5	110	16	36	98	6	14	9	48k6	42.5	110	16	36	98	6
LSRPM 200 L/L1/LU	16	10	55m6	49	110	20	42	97	13	16	10	55m6	49	110	20	42	97	13
LSRPM 225 ST1/MR1	18	11	60m6	53	140	20	42	126	14	18	11	60m6	53	140	20	42	126	14
LSRPM 250 SE/ME	18	11	65m6	58	140	20	42	126	14	18	11	65m6	58	140	20	42	126	14
LSRPM 280 SD	20	12	70m6	62.5	140	20	42	125	15	20	12	70m6	62.5	140	20	42	125	15
LSRPM 280 MD/MK1	20	12	75m6	67.5	140	20	42	125	15	20	12	75m6	67.5	140	20	42	125	15
LSRPM 315 SP1	22	14	80m6	71	170	20	42	155	15	22	14	80m6	71	170	20	42	155	15

DYNEO® VARIABLE SPEED DRIVES

Unidrive M variable speed drives/LSRPM permanent magnet synchronous motors Motor dimensions

Foot mounted IM B3 (IM 1001)

Dimensions in millimetres

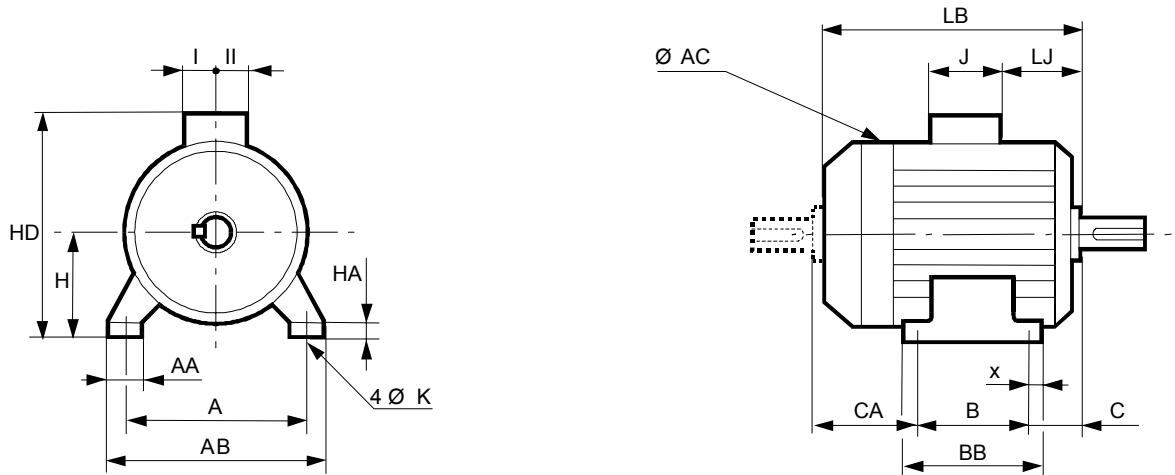

Type	Main dimensions																	
	A	AB	B	BB	C	X	AA	K	HA	H	AC	HD	LB	LJ	J	I	II	CA
LSRPM 90 SL	140	172	100	166	56	29	39	10	11	90	200	245	329	14	160	55	55	66
LSRPM 90 L	140	172	125	166	56	29	39	10	11	90	200	245	329	14	160	55	55	68
LSRPM 100 L	160	196	140	167	63	13	40	13	13	100	236	260	376	15	160	55	55	93
LSRPM 132 M	216	250	178	211	89	16	50	12	15	132	280	341	461	23	194	79	78	126
LSRPM 160 MP	254	294	254	298	108	22	64	14	25	160	310	391	555	53	186	112	95	154
LSRPM 160 LR	254	294	254	298	108	22	64	14	25	160	310	391	571	53	186	112	95	138
LSRPM 200 L	318	388	305	375	133	35	103	18.5	36	200	390	476	621	77	186	112	98	194
LSRPM 200 L1	318	388	305	375	133	35	103	18.5	36	200	390	510	621	55	231	119	141	194
LSRPM 200 LU	318	388	305	375	133	35	103	18.5	36	200	390	476	669	77	186	112	98	244
LSRPM 225 ST1	356	431	286	386	149	50	127	18.5	36	225	390	535	627	62	231	119	141	203
LSRPM 225 MR1	356	431	311	386	149	50	127	18.5	36	225	390	535	676	68	231	119	141	253
LSRPM 250 SE	406	470	311	420	168	35	90	24	36	250	479	655	810	68	292	148	180	341
LSRPM 250 ME	406	470	349	420	168	35	90	24	36	250	479	655	810	68	292	148	180	303
LSRPM 280 SD	457	520	368	478	190	35	90	24	35	280	479	685	870	68	292	148	180	322
LSRPM 280 MD	457	520	419	478	190	35	90	24	35	280	479	685	870	68	292	148	180	271
LSRPM 280 MK1	457	520	419	495	190	40	85	24	35	280	586	834	921	35	420	180	235	328
LSRPM 315 SP1	508	594	406	537	216	40	114	28	70	315	586	870	947	61	420	180	235	341

DYNEO® VARIABLE SPEED DRIVES

Unidrive M variable speed drives/LSRPM permanent magnet synchronous motors Motor dimensions

Foot and flange mounted IM B35 (IM 2001)

Dimensions in millimetres

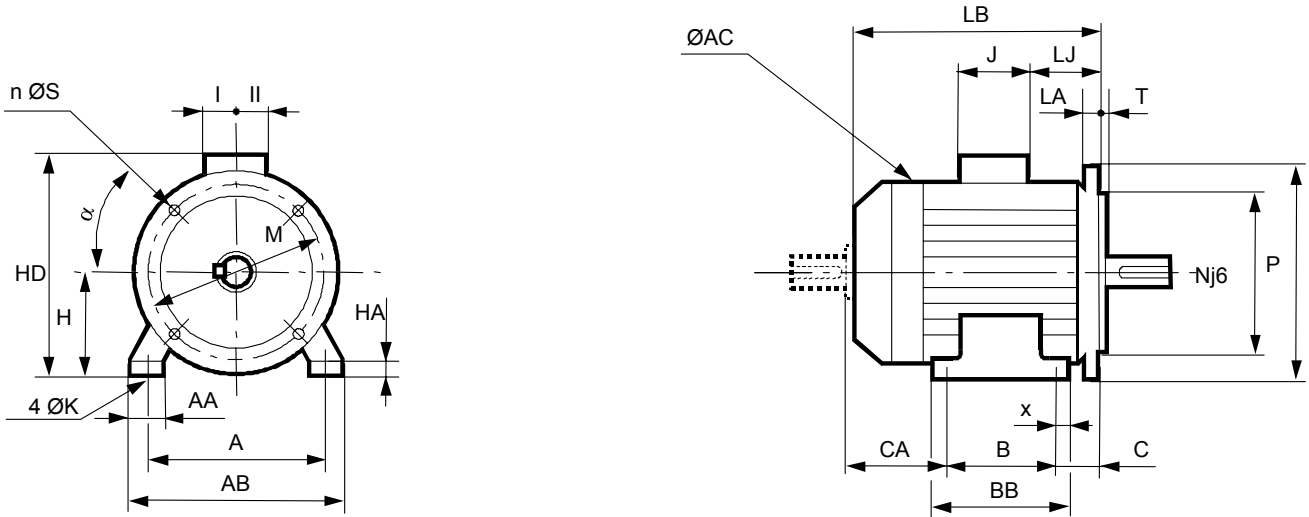

Type	Main dimensions																		
	A	AB	B	BB	C	X	AA	K	HA	H	AC	HD	LB	LJ	J	I	II	CA	Sym.
LSRPM 90 SL	140	172	100	166	56	29	39	10	11	90	200	245	351	14	160	55	55	66	FF165
LSRPM 90 L	140	172	125	166	56	29	39	10	11	90	200	245	351	14	160	55	55	68	FF165
LSRPM 100 L	160	196	140	167	63	13	40	13	13	100	236	260	376	15	160	55	55	93	FF215
LSRPM 132 M	216	250	178	211	89	16	50	12	15	132	280	341	461	23	194	79	78	126	FF265
LSRPM 160 MP	254	294	254	298	108	22	64	14	25	160	310	391	555	53	186	112	95	154	FF300
LSRPM 160 LR	254	294	254	298	108	22	64	14	25	160	310	391	571	53	186	112	95	138	FF300
LSRPM 200 L	318	388	305	375	133	35	103	18.5	36	200	390	476	621	77	186	112	98	194	FF350
LSRPM 200 L1	318	388	305	375	133	35	103	18.5	36	200	390	510	621	55	231	119	141	194	FF350
LSRPM 200 LU	318	388	305	375	133	35	103	18.5	36	200	390	476	669	77	186	112	98	244	FF350
LSRPM 225 ST1	356	431	286	386	149	50	127	18.5	36	225	390	535	627	62	231	119	141	203	FF400
LSRPM 225 SG	356	420	286	375	149	50	65	18.5	30	225	479	629	810	68	292	148	180	360	FF400
LSRPM 225 MR1	356	431	311	386	149	50	127	18.5	36	225	390	535	676	68	231	119	141	253	FF400
LSRPM 250 SE	406	470	311	420	168	35	90	24	36	250	479	655	810	68	292	148	180	341	FF500
LSRPM 250 ME	406	470	349	420	168	35	90	24	36	250	479	655	810	68	292	148	180	303	FF500
LSRPM 280 SD	457	520	368	478	190	35	90	24	35	280	479	685	870	68	292	148	180	322	FF500
LSRPM 280 MD	457	520	419	478	190	35	90	24	35	280	479	685	870	68	292	148	180	271	FF500
LSRPM 280 MK1	457	520	419	495	190	40	85	24	35	280	586	834	921	35	420	180	235	328	FF500
LSRPM 315 SP1	508	594	406	537	216	40	114	28	70	315	586	870	947	61	420	180	235	341	FF600

DYNEO® VARIABLE SPEED DRIVES

Unidrive M variable speed drives/LSRPM permanent magnet synchronous motors Motor dimensions

Flange mounted IM B5 (IM 3001)* IM V1 (IM 3011)

Dimensions in millimetres

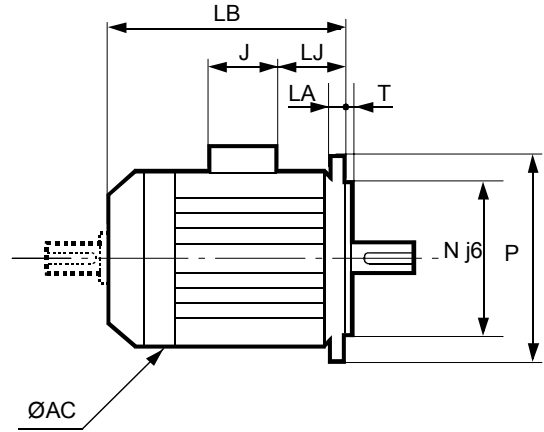
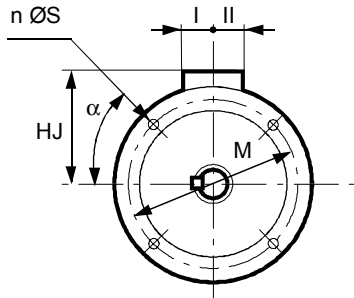

Symbol IEC	Faceplate dimensions								
	M	N	P	T	n	a	S	LA	
FF165	165	130	200	3.5	4	45	12	10	
FF165	165	130	200	3.5	4	45	12	10	
FF215	215	180	250	4	4	45	14.5	12	
FF265	265	230	300	4	4	45	14.5	14	
FF300	300	250	350	5	4	45	18.5	14	
FF300	300	250	350	5	4	45	18.5	14	
FF350	350	300	400	5	4	45	18.5	15	
FF350	350	300	400	5	4	45	18.5	15	
FF350	350	300	400	5	4	45	18.5	15	
FF400	400	350	450	5	8	22.5	18.5	15	
FF400	400	350	450	5	8	22.5	18.5	15	
FF400	400	350	450	5	8	22.5	18.5	15	
FF500	500	450	550	5	8	22.5	18.5	22	
FF500	500	450	550	5	8	22.5	18.5	22	
FF500	500	450	550	5	8	22.5	18.5	22	
FF500	500	450	550	5	8	22.5	18.5	22	
FF500	500	450	550	5	8	22.5	18.5	22	
FF600	600	550	660	6	8	22.5	24	22	

Type	Main dimensions						
	AC	LB	HJ	LJ	J	I	II
LSRPM 90 SL	200	351	155	34	160	55	55
LSRPM 90 L	200	351	155	34	160	55	55
LSRPM 100 L	200	376	160	15	160	55	55
LSRPM 132 M	264	461	209	23	194	79	78
LSRPM 160 MP	264	555	231	53	186	112	95
LSRPM 160 LR	264	571	231	53	186	112	95
LSRPM 200 L	390	621	276	77	186	112	98
LSRPM 200 L1	390	621	310	55	231	119	141
LSRPM 200 LU	390	669	276	77	186	112	98
LSRPM 225 ST1	390	627	310	61.5	231	119	141
LSRPM 225 SG	479	810	404	68	292	148	180
LSRPM 225 MR1	390	535	276	61.5	231	119	141
LSRPM 250 SE	479	810	405	68	292	148	180
LSRPM 250 ME	479	810	405	68	292	148	180
LSRPM 280 SD	479	870	405	68	292	148	180
LSRPM 280 MD	479	870	405	68	292	148	180
LSRPM 280 MK1	586	921	554	35	420	180	235
LSRPM 315 SP1	586	947	554	61	420	180	235

* for a frame size ≥ 250 mm for IM 3001 use, please consult us.

Dimensions of shaft extensions identical to those for foot mounted motors.

DYNEO® VARIABLE SPEED DRIVES

Unidrive M variable speed drives/LSRPM permanent magnet synchronous motors
Motor dimensions

Foot and face mounted IM B34 (IM 2101)

Dimensions in millimetres

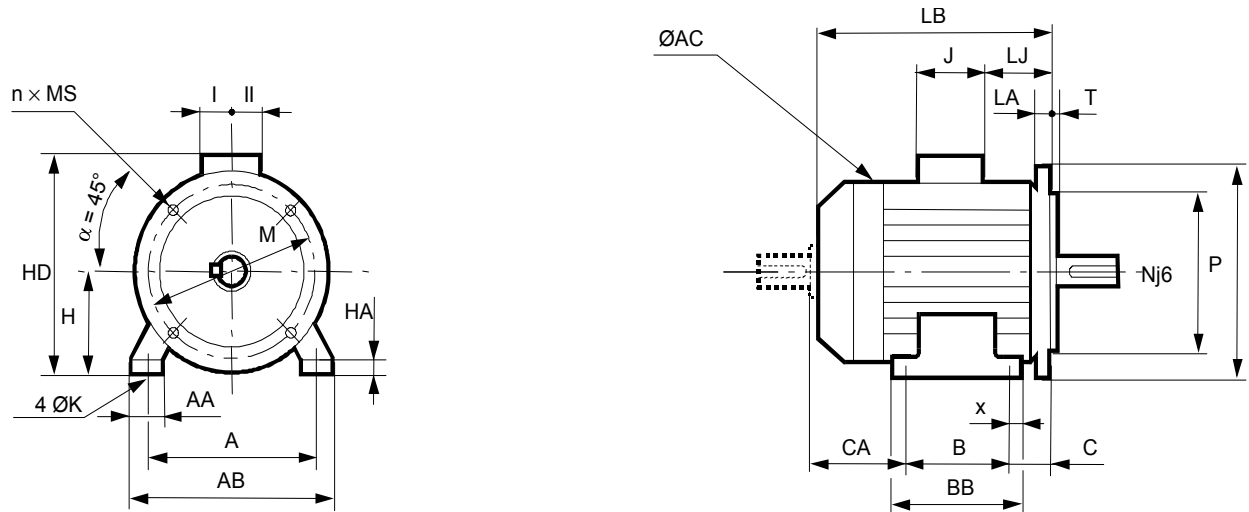

Type	Main dimensions																		
	A	AB	B	BB	C	X	AA	K	HA	H	AC	HD	LB	LJ	J	I	II	CA	Sym.
LSRPM 90 SL	140	172	100	166	56	29	39	10	11	90	200	245	329	14	160	55	55	66	FT115
LSRPM 90 L	140	172	125	166	56	29	39	10	11	90	200	245	329	14	160	55	55	68	FT115
LSRPM 100 L	160	196	140	167	63	13	40	13	13	100	236	260	376	15	160	55	55	93	FT130
LSRPM 132 M	216	250	178	211	89	16	50	12	15	132	264	341	461	23	194	79	78	126	FT215
LSRPM 160 MP	PLEASE CONSULT US																		
LSRPM 160 LR	PLEASE CONSULT US																		

DYNEO® VARIABLE SPEED DRIVES

Unidrive M variable speed drives/LSRPM permanent magnet synchronous motors Motor dimensions

Face mounted IM B14 (IM 3601)

Dimensions in millimetres

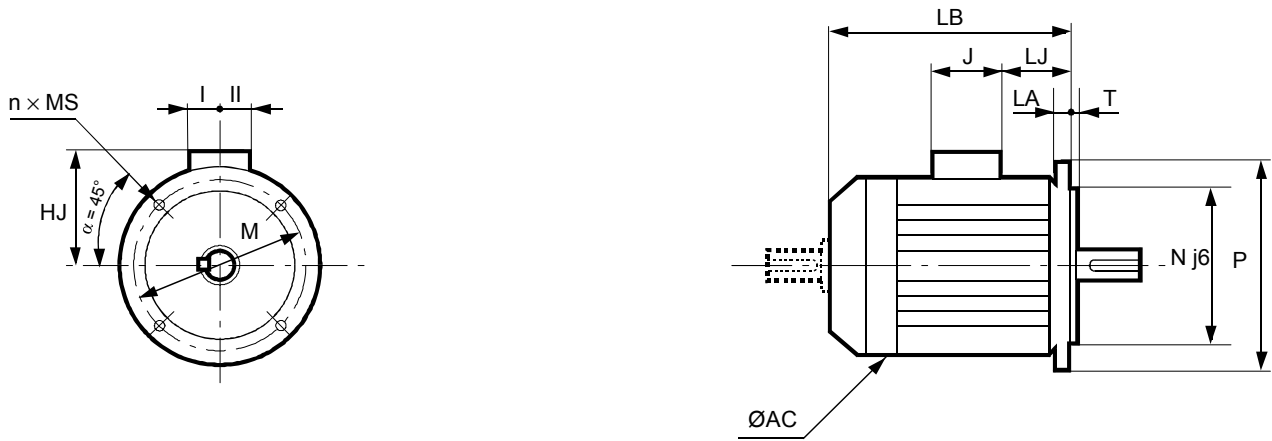

Symbol IEC	Flange dimensions						
	M	N	P	T	n	MS	
FT115	115	95	140	3	4	M8	
FT115	115	95	140	3	4	M8	
FT130	130	110	160	3.5	4	M8	
FT215	215	180	250	4	4	M12	
PLEASE CONSULT US							

Type	Main dimensions							
	AC	LB	HJ	LJ	J	I	II	CA
LSRPM 90 SL	200	329	155	14	160	55	55	-
LSRPM 90 L	200	329	155	14	160	55	55	-
LSRPM 100 L	236	376	160	15	160	55	55	-
LSRPM 132 M	264	461	209	23	194	79	78	126
LSRPM 160 MP LSRPM 160 LR	PLEASE CONSULT US							

Dimensions of shaft extensions identical to those for foot mounted motors.

DYNEO® VARIABLE SPEED DRIVES

Unidrive M variable speed drives/LSRPM permanent magnet synchronous motors Motor dimensions

Motors with options

Dimensions in millimetres

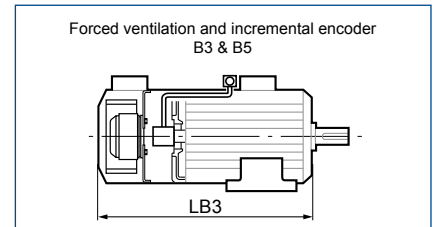
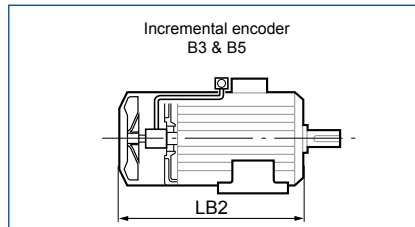
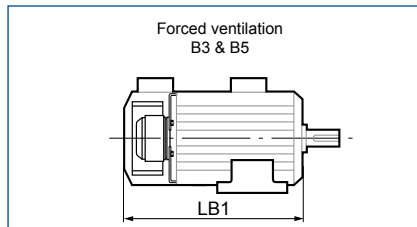

Type	LB ₁	LB ₂ *	LB ₃
LSRPM 90 SL	-	329	383
LSRPM 90 L	-	329	383
LSRPM 100 L	-	376	431
LSRPM 132 M	-	461	499
LSRPM 160 MP	-	555	710
LSRPM 160 LR	-	571	730
LSRPM 200 L/L1	802	674	802
LSRPM 200 LU/LU1	847	723	847
LSRPM 225 ST1	808	681	808
LSRPM 225 MR	854	730	854
LSRPM 250 SE	1012	860	1012
LSRPM 250 ME	1012	860	1012
LSRPM 280 SD	1072	920	1072
LSRPM 280 MD	1072	920	1072
LSRPM 280 MK	1075	965	1075
LSRPM 315 SP	1137	991	1137













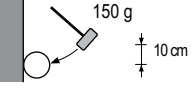

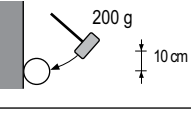



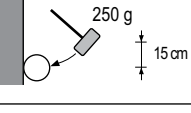



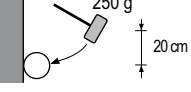

*LB₂: standard mounting frame sizes 90 to 160

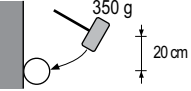
NB: Dimensions of motors with single-turn and multi-turn absolute encoders will be supplied on request.

Definition of “Index of Protection” (IP/IK)

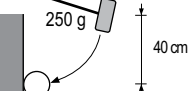
In standard configuration the motors are IP 55/IK 08 for LSRPM

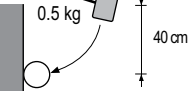
Indices of protection of electrical equipment enclosures
In accordance with IEC 60034-5 - EN 60034-5 (IP) - IEC 62262 (IK)

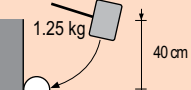
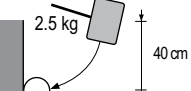
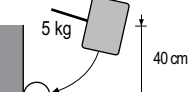
1st number: Protection against solid objects			2nd number: Protection against liquids			3rd number: Mechanical protection		
IP	Tests	Definition	IP	Tests	Definition	IK	Tests	Definition
0		No protection	0		No protection	00		No protection
1	Ø 50 mm 	Protected against solid objects larger than 50 mm (e.g. accidental contact with the hand)	1 		Protected against water drops falling vertically (condensation)	01		Impact energy: 0.15 J
2	Ø 12 mm 	Protected against solid objects larger than 12 mm (e.g. a finger)	2 	15°	Protected against water drops falling at up to 15° from the vertical	02		Impact energy: 0.20 J
3	Ø 2.5 mm 	Protected against solid objects larger than 2.5 mm (e.g. tools, wires)	3 	60° 	Protected against rain falling at up to 60° from the vertical	03		Impact energy: 0.37 J
4	Ø 1 mm 	Protected against solid objects larger than 1 mm (e.g. thin tools, small wires)	4 		Protected against projected water from all directions	04		Impact energy: 0.50 J
5	 	Protected against dust (no deposits of harmful material)	5 		Projected against jets of water from all directions from a hose	05		Impact energy: 0.70 J
6	 	Protected against any dust penetration	6 		Protected against projected water comparable to big waves	06		Impact energy: 1 J
Example:			7 		Protected against the effects of immersion between 0.15 and 1 m	07		Impact energy: 2 J
Example of an IP 55 machine			8 		Protected against prolonged effects of immersion under pressure	08		Impact energy: 5 J
IP : Ingress protection						09		Impact energy: 10 J
.5 : Machine protected against dust and accidental contact. Test result: no dust enters in harmful quantities, no risk of direct contact with rotating parts. The test will last for 2 hours.						10		Impact energy: 20 J
.5 : Machine protected against jets of water from all directions from hoses at 3 m distance with a flow rate of 12.5 l/min at 0.3 bar. The test will last for 3 minutes. Test result: no damage from water projected onto the machine.								

External finishing

Emerson Industrial Automation motors are protected with a range of surface finishes. The surfaces receive appropriate special treatments, as shown below.

Preparation of surfaces

SUPPORT	PARTS	TREATMENT
Cast iron	End shields	Shot blasting + Primer
Steel	Accessories	Phosphatization + Primer
	Terminal boxes - Fan covers	Electrostatic painting or Epoxy powder
Aluminium alloy	Housings - Terminal boxes	Shot blasting

Definition of atmospheres

An atmosphere is said to be harsh when components are attacked by bases, acids or salts. It is said to be corrosive when components are attacked by oxygen.

Paint systems

ATMOSPHERE	SYSTEM	APPLICATIONS	CORROSIVITY CATEGORY * ACC. TO ISO 12944-2
Non-harsh and not very harsh (indoors, rural, industrial)	Ia LSRPM - PLSRPM standard	1 polyurethane top coat 20/30 µm	C3L
Moderately corrosive: humid, and outdoors (temperate climate)	IIa	1 Epoxy base coat 30/40 µm 1 polyurethane top coat 20/30 µm	C3M
Corrosive: maritime, very humid (tropical climate)	IIIa	1 Epoxy base coat 30/40 µm 1 Epoxy intermediate coat 30/40 µm 1 polyurethane top coat 20/30 µm	C4M
Substantial chemical attack: frequent contact with bases, acids, alkali Surroundings - neutral environment (not in contact with chlorinated or sulphurous products)	IIIb**	1 Epoxy base coat 30/40 µm 1 Epoxy intermediate coat 30/40 µm 1 Epoxy top coat 25/35 µm	C4H
Special conditions Very harsh, polluted with chlorinated or sulphurous products	Vc**	1 Epoxy base coat 20/30 µm 2 Epoxy intermediate coats, each 35/40 µm 1 polyurethane top coat 35/40 µm	C5I-M
	161b**	1 base coat 50 µm 2 intermediate coats Epoxy 80 µm 1 Epoxy top coat 50 µm	C5M-M

System **Ia** is for moderate climates and System **IIa** is for general climates as defined in standard IEC 60721.2.1.

* Values given for information only since the substrates vary in nature whereas the standard only takes account of steel substrates.



** Assessment of degree of rusting in accordance with standard ISO 4628 (rust over 1 to 0.5% of the surface)

Emerson Industrial Automation standard paint colour reference:

RAL 3005

Mounting arrangements

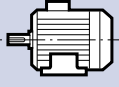
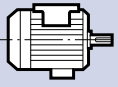
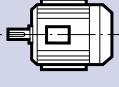
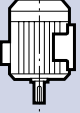
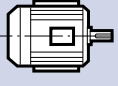
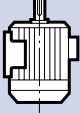
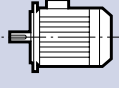
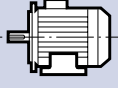
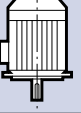
Mountings and positions (IEC standard 60034-7)

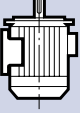
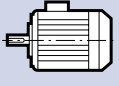
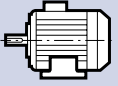
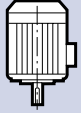
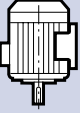
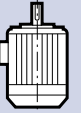
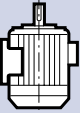
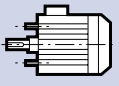
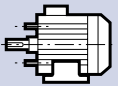
Foot mounted motors • all frame sizes	IM 1001 (IM B3) - Horizontal shaft - Feet on floor 	IM 1071 (IM B8) - Horizontal shaft - Feet on top 
	IM 1051 (IM B6) - Horizontal shaft - Wall mounted with feet on left when viewed from drive end 	IM 1011 (IM V5) - Vertical shaft facing down - Feet on wall 
	IM 1061 (IM B7) - Horizontal shaft - Wall mounted with feet on right when viewed from drive end 	IM 1031 (IM V6) - Vertical shaft facing up - Feet on wall 
(FF) flange mounted motors • all frame sizes (except IM 3001, which is limited to frame size 225 mm)	IM 3001 (IM B5) - Horizontal shaft 	IM 2001 (IM B35) - Horizontal shaft - Feet on floor 
	IM 3011 (IM V1) - Vertical shaft facing down 	IM 2011 (IM V15) - Vertical shaft facing down - Feet on wall 
	IM 3031 (IM V3) - Vertical shaft facing up 	IM 2031 (IM V36) - Vertical shaft facing up - Feet on wall 
(FT) face mounted motors • all frame sizes ≤ 132 mm	IM 3601 (IM B14) - Horizontal shaft 	IM 2101 (IM B34) - Horizontal shaft - Feet on floor 
	IM 3611 (IM V18) - Vertical shaft facing down 	IM 2111 (IM V58) - Vertical shaft facing down - Feet on wall 
	IM 3631 (IM V19) - Vertical shaft facing up 	IM 2131 (IM V69) - Vertical shaft facing up - Feet on wall 
Motors without drive end shield Caution: the protection (IP) specified on the IM B9 and IM B15 motor nameplates is provided by the customer when the motor is assembled	IM 9101 (IM B9) - Threaded tie rods - Horizontal shaft 	IM 1201 (IM B15) - Foot mounted with threaded tie rods - Horizontal shaft 

Frame size (mm)	Mounting positions											
	IM 1001	IM 1051	IM 1061	IM 1071	IM 1011	IM 1031	IM 3001	IM 3011	IM 3031	IM 2001	IM 2011	IM 2031
≤ 200	●	●	●	●	●	●	●	●	●	●	●	●
225 and 250	●	●	●	●	●	●	■	●	●	●	●	●
≥ 280	●	■	■	■	■	■	■	●	●	●	●	■

●: possible positions.

■: please consult Emerson Industrial Automation specifying the coupling method and the axial and radial loads if applicable

Bearings and lubrication

Type of grease

When the bearings are not greased for life, the type of grease is indicated on the nameplate. As standard, this grease is EXXON MOBILE POLYREX EM103 and we recommend that this is used for subsequent lubrication.

Avoid mixing greases

Permanently greased bearings

Under normal operating conditions, the service life (L10h) of the lubricant is 25,000 hours for a machine installed horizontally and for temperatures less than 25°C.

Bearings with grease nipples

The bearings are lubricated in the factory

The end shields are fitted with bearings lubricated by Técalémit grease nipples.

The frequency of lubrication and quantity and quality of grease are indicated on the nameplates. Refer to these to ensure correct lubrication of the bearings.

Even in the event of prolonged storage or downtime, the interval between 2 greasing operations should never exceed 2 years.

Bearings and types of grease nipple

Range	Frame size (mm)	Lubrication type	Ball bearing type	
		N.D.E./D.E.	N.D.E.	D.E.
5500	≤ 160	Greased for life in the factory	Standard	Standard
	200	Bearings with grease nipples	Insulated	Insulated
4500	≤ 160	Greased for life in the factory	Standard	Standard
	200	Bearings with grease nipples	Insulated	Standard
	> 200	Bearings with grease nipples	Insulated	Insulated
3600	≤ 200	Greased for life in the factory	Standard	Standard
	> 200	Bearings with grease nipples	Insulated for frame size > 250	Standard
3000	≤ 200	Greased for life in the factory	Standard	Standard
	> 200	Bearings with grease nipples	Insulated for frame size > 250	Standard
2400	≤ 200	Greased for life in the factory	Standard	Standard
	> 200	Bearings with grease nipples	Insulated for frame size > 280SD	Standard
1800	≤ 200	Greased for life in the factory	Standard	Standard
	> 200	Bearings with grease nipples	Insulated for frame size > 280	Standard
1500	≤ 200	Greased for life in the factory	Standard	Standard
	> 200	Bearings with grease nipples	Insulated for frame size > 280	Standard
900	≤ 200	Greased for life in the factory	Standard	Standard
	> 200	Bearings with grease nipples	Standard	Standard
750	≤ 200	Greased for life in the factory	Standard	Standard
	> 200	Bearings with grease nipples	Standard	Standard

Permissible loads

Permissible loads: Motors in the 750 to 3600 series are designed to operate with direct or indirect coupling: permissible loads on request.

Motors in the 4500 and 5500 series are designed to operate with direct coupling. For other cases, please consult us.

Precautions

For the 4500 and 5500 series, a running-in period is necessary. Please refer to the installation and maintenance manual.

DYNEO® VARIABLE SPEED DRIVES

Unidrive M variable speed drives/LSRPM permanent magnet synchronous motors Motor construction

Connection

Terminal box

Placed as standard on the top of the motor near the drive end, the terminal box has IP55 protection.

The standard position of the cable gland baseplate is on the right, seen from the drive end, position A1.

Tightening torque for the nuts on the terminal blocks

Terminal	M4	M5	M6	M8	M10	M12	M16
Torque N.m	2	3.2	5	10	20	35	65

▼ Terminal box positions in relation to the drive end

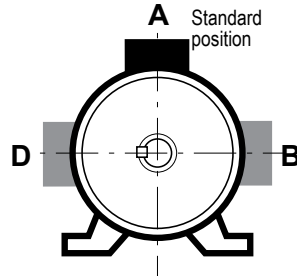

▼ Positions of the cable gland in relation to the drive end

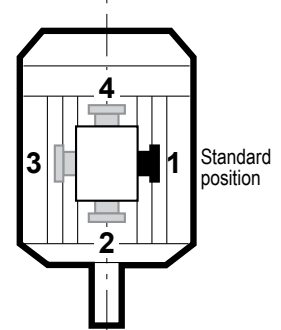

Only positions 1 and 3 are possible

Terminal box drilling for cable glands

Motor type	Power + auxiliaries	
	Number of drill holes	Drill hole diameter
LSRPM 90 S/SL	2	ISO M25x1.5 + 1xM16
LSRPM 100 L		ISO M40x1.5 + 1xM16
LSRPM 132 M		ISO M50x1.5 + 1xM16
LSRPM 160 LR/MP	3	2xM40 + 1xM16
LSRPM 200 L/LU		2xM50 + 1xM16
LSRPM 200 L1		2xM63 + 1xM16
LSRPM 200 L2/LU2		2xM50 + 1xM16
LSRPM 225 ST1/MR1		2xM63 + 1xM16
LSRPM 225 SG/ST2/SR2		2xM63 + 1xM16
LSRPM 250 SE/ME		2xM63 + 1xM16
LSRPM 250 SE1/ME1		Removable undrilled mounting plate
LSRPM 280 SD/MD	2xM63 + 1xM16	
LSRPM 280 MK1	0	Removable undrilled mounting plate
LSRPM 315 SP1		

DYNEO® VARIABLE SPEED DRIVES

Unidrive M variable speed drives/LSRPM permanent magnet synchronous motors
 Motor construction

Motor vibration levels

Maximum vibration magnitude limits (rms values) in terms of displacement, speed and acceleration for a frame size H (IEC 60034-14)

The machines in this catalogue are in vibration class:
 - level A for $n \leq 3000 \text{ min}^{-1}$
 - level B for $n > 3000 \text{ min}^{-1}$
 and half-key balancing (H)

Vibration level	Frame size H (mm)								
	56 < H ≤ 132			132 < H ≤ 280			H > 280		
	Displacement μm	Speed mm/s	Acceleration m/s^2	Displacement μm	Speed mm/s	Acceleration m/s^2	Displacement μm	Speed mm/s	Acceleration m/s^2
A	25	1.6	2.5	35	2.2	3.5	45	2.8	4.4
B	11	0.7	1.1	18	1.1	1.7	29	1.8	2.8

Quality commitment

Emerson Industrial Automation's quality management system is based on:

- Control of procedures right from the initial sales offering until delivery to the customer, including design, manufacturing start-up and production
- A total quality policy based on making continuous progress in improving operational procedures, involving all departments in the company in order to give customer satisfaction as regards delivery times, conformity and cost

- Indicators used to monitor procedure performance

- Corrective actions and advancements with tools such as FMECA, QFD, MAVP, MSP/MSQ and Hoshin type improvement workshops on flows, process re-engineering, plus Lean Manufacturing and Lean Office

- Annual surveys, opinion polls and regular visits to customers in order to ascertain and detect their expectations

Personnel are trained and take part in analyses and actions for continuous improvement of our procedures.

Emerson Industrial Automation has entrusted the certification of its expertise to various international organisations. Certification is granted by independent professional auditors, and recognises the high standards of the **company's quality assurance procedures**. All activities resulting in the final version of the machine have therefore received official certification **ISO 9001: 2008 from the DNV**. Similarly, our environmental approach has enabled us to obtain certification ISO 14001: 2004. Products for particular applications or those designed to operate in specific environments are also approved or certified by the following organisations: LCIE, DNV, INERIS, EFECTIS, UL, BSRIA, TUV, GOST, which check their technical performance against the various standards or recommendations.



ISO 9001 : 2008



Standards and approvals

**Our motors comply with
the standards quoted in this catalogue**

List of standards quoted in this document

Reference		International standards
IEC 60034-1	EN 60034-1	Electrical rotating machines: ratings and operating characteristics.
IEC 60034-2-1		Electrical rotating machines: methods for determining losses and efficiency from tests (measured additional losses).
IEC 60034-5	EN 60034-5	Electrical rotating machines: classification of degrees of protection provided by casings of rotating machines.
IEC 60034-6	EN 60034-6	Electrical rotating machines (except traction): cooling methods.
IEC 60034-7	EN 60034-7	Electrical rotating machines (except traction): symbols for mounting positions and assembly layouts.
IEC 60034-8		Electrical rotating machines: terminal markings and direction of rotation.
IEC 60034-9	EN 60034-9	Electrical rotating machines: noise limits.
IEC 60034-12	EN 60034-12	Starting characteristics for single-speed 3-phase cage induction motors for supply voltages less than or equal to 660V.
IEC 60034-14	EN 60034-14	Electrical rotating machines: mechanical vibrations of certain machines with a frame size above or equal to 56 mm. Measurement, evaluation and limits of vibrational intensity.
IEC 60034-17		Cage induction motors supplied by inverters - Application guide.
IEC 60034-30		Electrical rotating machines: efficiency classes for single-speed three-phase cage induction motors (Code IE)
IEC 60038		IEC standard voltages.
IEC 60072-1		Dimensions and power series for electrical rotating machines: designation of casings between 56 and 400 and flanges between 55 and 1080.
IEC 60085		Evaluation and thermal classification of electrical insulation.
IEC 60721-2-1		Classification of natural environment conditions. Temperature and humidity.
IEC 60892		Effects of an imbalance in the voltage system on the characteristics of three-phase squirrel-cage induction motors.
IEC 61000-2-10/11 and 2-2		Electromagnetic compatibility (EMC): environment.
IEC guide 106		Guidelines on the specification of environmental conditions for the determination of operating characteristics of equipment.
ISO 281		Bearings - Dynamic load ratings and nominal bearing life.
ISO 1680	EN 21680	Acoustics - Test code for measuring airborne noise emitted by electrical rotating machines: a method for establishing an expert opinion for free field conditions over a reflective surface.
ISO 8821		Mechanical vibration - Balancing. Conventions on shaft keys and related parts.
	EN 50102	Degree of protection provided by electrical enclosures against extreme mechanical impacts.
ISO 12944-2		Corrosivity category

DYNEO® VARIABLE SPEED DRIVES

Unidrive M variable speed drives/LSRPM permanent magnet synchronous motors General information

Standards and approvals

Approvals

Certain countries recommend or insist on approval from national organizations.
Approved products must carry the recognized mark on their nameplates.

Country	Initials	Organization
USA	UL	Underwriters Laboratories
CANADA	CSA	Canadian Standards Association
etc.		

Approvals for Emerson Industrial Automation motors (versions derived from standard construction):

Country	Initials	Certification No.	Application
CANADA	CSA	LR 57 008	Standard adapted range (see "Supply voltage" section)
USA	UL or FU	E 68554 SA 6704 E 206450	Impregnation systems Stator/rotor assemblies for sealed units Complete motors up to 160 size
USA + Canada		E 68554	Impregnation systems
SAUDI ARABIA	SASO		Standard range
FRANCE	LCIE INERIS	Various n ^{os}	Sealing, shocks, safety

For approved specific products, see the relevant documents.

International and national standard equivalents

International reference standards		National standards				
IEC	Title (summary)	FRANCE	GERMANY	UK	ITALY	SWITZERLAND
60034-1	Ratings and operating characteristics	NFEN 60034-1 NFC 51-120 NFC 51-200	DIN/VDE 0530	BS 4999	CEI 2.3.VI.	SEV ASE 3009
60034-5	Classification of degrees of protection	NFEN 60034-5	DIN/EN 60034-5	BS EN 60034-5	UNELB 1781	
60034-6	Cooling methods	NFEN 60034-6	DIN/EN 60034-6	BS EN 60034-6		
60034-7	Mounting arrangements and assembly layouts	NFEN 60034-7	DIN/EN 60034-7	BS EN 60034-7		
60034-8	Terminal markings and direction of rotation	NFC 51 118	DIN/VDE 0530 Teil 8	BS 4999-108		
60034-9	Noise limits	NFEN 60034-9	DIN/EN 60034-9	BS EN 60034-9		
60034-12	Starting characteristics for single-speed motors for supply voltages ≤ 660 V	NFEN 60034-12	DIN/EN 60034-12	BS EN 60034-12		SEV ASE 3009-12
60034-14	Mechanical vibrations of machines with frame size ≥ 56 mm	NFEN 60034-14	DIN/EN 60034-14	BS EN 60034-14		
60072-1	Dimensions and output powers for machines of between 56 and 400 frame size and flanges of between 55 and 1080.	NFC 51 104 NFC 51 105	DIN 748 (-) DIN 42672 DIN 42673 DIN 42631 DIN 42676 DIN 42677	BS 4999		
60085	Evaluation and thermal classification of electrical insulation	NFC 26206	DIN/EN 60085	BS 2757		SEV ASE 3584

NB: DIN 748 tolerances do not conform to IEC 60072-1.

DYNEO® VARIABLE SPEED DRIVES

Unidrive M variable speed drives/LSRPM permanent magnet synchronous motors General information

Nameplates

Receipt

On receipt of your motor, check that it has not suffered any damage in transit.

If there are obvious signs of damage, contact the carrier (you may be able to claim on their insurance) and after a visual check, turn the motor to detect any malfunction.

Identification

As soon as you receive the motor, check that the nameplate on the machine conforms to your order.

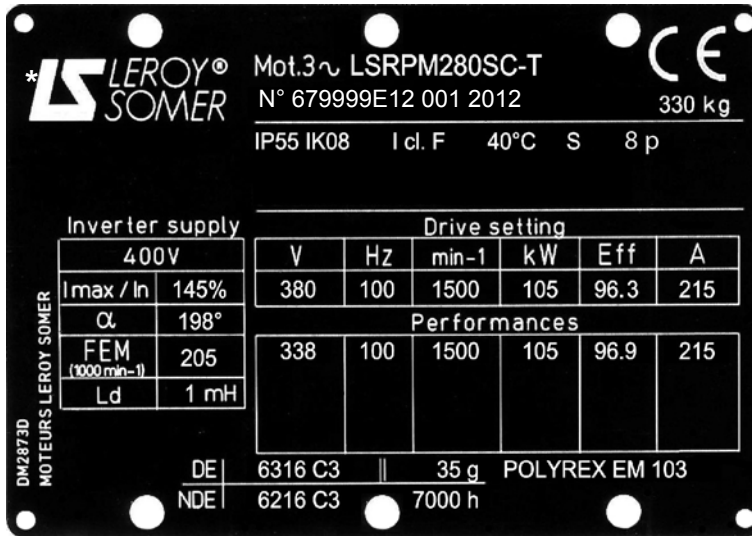

* Other logos can optionally be provided: agreement prior to ordering is essential.

Definition of symbols used on nameplates:



Legal mark of conformity of product to the requirements of European Directives.

- MOT 3~** : Three-phase A.C. motor
- LSRPM** : Series
- 280** : Frame size
- SC** : Housing designation and manufacturer code
- T** : Impregnation index

Motor

679999 : Serial number

For motor types 200 to 315:

- E** : Month of production
- 12** : Year of production
- 001** : Batch number

- IP55 IK08** : Degree of protection
- (I) cl. F** : Insulation class F
- 40°C** : Ambient operating temperature
- S** : Duty
- %** : Operating factor
- 8 p** : Number of poles
- ...d/h** : Number of cycles per hour
- kg** : Weight

FEM : Electromotive force

- α : Phase angle
- Ld** : Transient inductance

Drive setting: Settings to be entered in the drive

Performances: Motor characteristics

- Hz** : Supply frequency
- min⁻¹** : Revolutions per minute (rpm)
- kW** : Rated power
- Eff** : Efficiency
- A** : Rated current

Bearings

- DE** : Drive end bearing
- NDE** : Non drive end bearings - RI: Insulated bearing
- 35 g** : Amount of grease at each regreasing (in cm³)
- 7000 hrs at 1500 min⁻¹** : Regreasing interval (in hours) for θ_{amb}
- POLYREX EM 103**: Type of grease

DYNEO® VARIABLE SPEED DRIVES

Unidrive M variable speed drives/LSRPM permanent magnet synchronous motors
General information

Configurator



The configurator can be used to choose the most suitable motor and variable speed and provides the technical specifications and corresponding drawings.

- Help with product selection
- Print-outs of technical specifications
- Print-outs of 2D and 3D CAD files
- The equivalent of 300 catalogues in 10 languages

To register online:
www.leyoer-somer.com/en/solutions_and_services/drive_systems/configurator

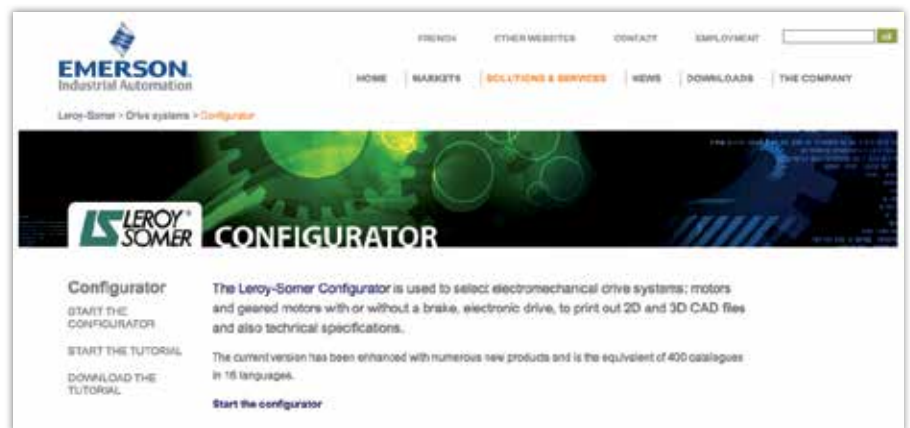



EMERSON™

Industrial Automation



www.emersonindustrial.com

© - This document is the property of Emerson Industrial Automation, it can not be reproduced in any form without prior written authorization. Emerson Industrial Automation reserves the right to modify the design, technical specifications and dimensions of the products shown in this document. The descriptions cannot in any way be considered contractual.

Moteurs Leroy-Somer SAS - RCS 338 567 258 ANGOULÊME - Capital de 65 800 512 €

The Emerson logo is a trademark and service mark of Emerson Electric Co. © 2013

EMERSON. CONSIDER IT SOLVED.™