



Operation **Manual**

Hardware Manual of Goodrive800 Series Products



SHENZHEN INVT ELECTRIC CO., LTD.

Preface

Thank you for purchasing our products.

Please read this manual carefully before any application.

Goodrive800 series products are developed for sophisticated application market which needs high overload capacity, high reliability and continuous operations. Its rated current is especially designed for various heavy-load applications such as metallurgy, port machinery, lifting, shore power, petroleum, petrochemical, municipal, chemical, electric power, building materials, mining, ship-building, paper-making and other industries and devices.

Goodrive800 series products apply international module, providing rectifier unit, IGBT, filter unit or whole cabinet to meet requirements of end-users and clients of OEM and integrated system. Different modules can be combined flexibly according to different requirement on the basic of standard configuration. Not only the user can control machines at high precision, but also present the excellent product reliability. Various solution applications are also provided to improve the convenient application at a great rate.

There are hardware manual, software manual, commissioning manual, installation and maintenance manual and application manual, to provide detailed instruction of installation and commissioning, electrical connections, parameters setting, common troubleshooting and routine maintenance. Please read corresponding manual during installation, commissioning and application to ensure proper use and long service life of the product.

If the product is ultimately used for military affairs or manufacture of weapon, it will be listed on the export control formulated by *Foreign Trade Law of the People's Republic of China*. Rigorous review and necessary export formalities are needed when exported.

Our company reserves the right to update the information of our products. Information may be subject to change without notice during product improving.

The manuals of Goodrive800 include (according to actual order):

Software Manual of Goodrive800 Series Inverters;

Hardware Manual of Goodrive800 Series Inverters;

Software Manual of Goodrive800 Series PWM Rectifiers;

Installation and Maintenance Manual of Goodrive800 Series Products and;

Application Manual of Goodrive800 Series Products.

Content

Preface.....	1
Content.....	2
Chapter 1 Safety precautions	5
1.1 Safety definition.....	5
1.2 Warning symbols.....	5
1.3 Safety guidelines.....	5
1.3.1 Delivery and installation.....	6
1.3.2 Time and sequence when power on/off.....	6
1.3.3 Commissioning and running.....	7
1.3.3 Maintenance and replacement of components.....	8
1.3.4 What to do after scrapping.....	8
1.4 Precautions of installation and applications	8
1.4.1 Do not connect the output of inverter to capacitor	8
1.4.2 Cable requirements of parallel connection (inverters or power units).....	8
Chapter 2 Application precautions	10
2.1 Inspection before power on.....	10
2.1.1 Unpacking inspection.....	10
2.1.2 Application confirmation.....	10
2.1.3 Environment.....	10
2.1.4 Installation confirmation	10
2.2 Environmental requirements of the product	11
2.3 Derating of Goodrive800 series products.....	12
2.3.1 Capacity.....	12
2.3.2 Derating	12
2.4 Application standards	13
2.4.1 CE mark.....	13
2.4.2 Compliance with the European EMC Directive.....	13
2.5 EMC regulations.....	13
2.5.1 Category C2.....	14
2.5.2 Category C3.....	14
Chapter 3 Technical parameters	15
3.1 Product name plate	15
3.2 Product model and name.....	15
3.2.1 Model of Goodrive800 series products	15
3.2.2 Model of Goodrive800 control unit.....	16
3.2.3 Model of Goodrive800 optional unit.....	16
3.2.4 Product name of Goodrive800 series models.....	16
3.2.5 Products comparison	19
3.3 Product specifications.....	20
3.3.1 Product specifications of Goodrive800-51 series power unit.....	20
3.3.2 Product specifications of Goodrive800-11 series inverter unit.....	21
3.3.3 Product specifications of Goodrive800-61 diode rectification unit.....	22
3.3.4 Product specifications of Goodrive800-16 inverter unit.....	23
3.3.5 Product specifications of Goodrive800-26 series four-quadrant cabinet inverter.....	24
3.3.6 Product specifications of Goodrive800-56 series standard IGBT cabinet.....	26

3.3.7 Product specifications of Goodrive800-96 series cabinet IGBT PWM rectifier	28
3.3.8 Product specifications of Goodrive800-01 LCL PWM filter unit.....	29
3.3.9 Product specifications of Goodrive800 control unit.....	30
3.4 Main rated parameters	32
3.4.1 Main parameters of Goodrive800-11 inverter unit.....	33
3.4.2 Main parameters of Goodrive800-51 series power unit.....	36
3.4.3 Main parameters of Goodrive800-61 series diode rectification unit.....	38
3.4.4 Main parameters of Goodrive800-26 series four-quadrant cabinet inverter.....	39
3.4.5 Main parameters of Goodrive800-56 series cabinet inverter.....	42
3.4.6 Main parameters of Goodrive800-96 series cabinet IGBT PWM rectifier	44
3.4.7 Main parameters of Goodrive800-01 LCL PWM filter unit.....	47
3.4.8 Main parameters of Goodrive800-02 series sine wave filter unit.....	48
3.4.9 Main parameters of Goodrive800-03 series bus capacitor energy storage / filter unit... 49	
3.4.10 Model of Goodrive800 series control unit.....	50
3.5 Loss calculation of inverters.....	53
Chapter 4 Electrical connection	56
4.1 Wiring diagram of Goodrive800-26, Goodrive800-96 and Goodrive800-56 series products ...	56
4.2 Wiring diagram of Goodrive800-11 series inverter unit.....	59
4.2.1 Goodrive800-11 series 0004~0030-4 and 0004~0030-5.....	59
4.2.2 Goodrive800-11 series 0037~0110-4, 0037~0110-5 and 0022~0132-6	60
4.2.3 Goodrive800-11 series 0132~0200-4, 0132~0200-5 and 0160~0250-6.....	60
4.2.4 Goodrive800-11 series 0250~0400-4, 0250~0400-5 and 0315~0500-6.....	61
4.3 Wiring diagram of Goodrive800-51 series convertering unit.....	62
4.3.1 Goodrive800-51 series 0075~0110-4, 0075~0110-5 and 0075~0132-6.....	62
4.3.2 Goodrive800-51 series 0132~0200-4, 0132~0200-5 and 0160~0250-6.....	62
4.3.3 Goodrive800-51 series 0250~0400-4, 0250~0400-5 and 0315~0500-6.....	63
4.4 Wiring diagram of Goodrive800-61 series diode rectification unit.....	64
4.5 Wiring diagram of Goodrive800-71 series silicon-controlled rectification unit.....	64
4.6 Wiring diagram of Goodrive800-81 series IGBT synchronous rectification unit.....	65
4.7 Wiring diagram of Goodrive800-01 series LCL PWM filter unit	65
4.8 Wiring diagram of Goodrive800-02 series sine wave filter unit.....	66
4.9 Wiring diagram of Goodrive800-03 series bus capacitor energy storage/filter unit.....	66
4.10 Schematic diagram of Goodrive800 series control units	67
4.10.1 Wiring of control circuit.....	68
4.10.2 Control terminals	69
4.11 Goodrive800-51 series unit control board	71
4.12 Goodrive800-61, Goodrive800-71, Goodrive800-81 and Goodrive800-91 series rectification control board.....	71
Chapter 5 Configuration table of the cabinets.....	73
5.1 Configuration table of Goodrive800-26 series products.....	73
5.2 Configuration table of Goodrive800-96 series products.....	75
5.3 Configuration table of Goodrive800-56 series products.....	78
Chapter 6 Main components.....	79
6.1 Goodrive800 series cabinet products	79
6.2 Goodrive800 series control cabinets	85
Chapter 7 Dimensions.....	86
7.1 Dimension of Goodrive800-26, Goodrive800-96 and Goodrive800-56	86

7.1.1 26S1 dimensions.....	86
7.1.2 26S2 dimensions.....	87
7.1.3 26S3 dimensions.....	88
7.1.4 26M1, 56S1 and 96M1 dimensions.....	89
7.1.5 26M2, 56S2 and 96M2 dimensions.....	90
7.1.6 26M3, 56M1 and 96M3 dimensions.....	91
7.2 Goodrive800-11 series.....	92
7.2.1 Dimension of Goodrive800-11 series 11A1~11A6 for wall installation.....	92
7.2.2 Dimension of Goodrive800-11 series 11A1~11A6 for flange installation.....	93
7.2.3 Dimension of Goodrive800-11 series 11A7.....	94
7.2.4 Dimension of Goodrive800-11 series 11A8.....	95
7.2.5 Dimension of Goodrive800-11 series 11B7~11B8.....	96
7.2.6 Dimension of Goodrive800-11 series 11B7.....	97
7.2.7 Dimension of Goodrive800-11 series 11B8~11B9.....	98
7.3 Goodrive800-51 series.....	99
7.3.1 Dimensions of Goodrive800-51 series 51A5.....	99
7.3.2 Dimensions of Goodrive800-51 series 51A6.....	99
7.3.3 Dimensions of Goodrive800-51 series 51A7.....	100
7.3.4 Dimensions of Goodrive800-51 series 51A8.....	101
7.3.5 Dimensions of Goodrive800-51 series 51B7.....	102
7.4 Goodrive800-61 series.....	103
7.4.1 Dimensions of Goodrive800-61 series 61A7.....	103
7.4.2 Dimensions of Goodrive800-61 series 61A8.....	103
7.5 Goodrive800-01 series.....	104
7.5.1 Dimensions of Goodrive800-01 series 01A8.....	104
7.6 Goodrive800-02 series.....	105
7.6.1 Dimensions of Goodrive800-02 series 02A8.....	105
7.7 Goodrive800-03 series.....	106
7.7.1 Dimensions of Goodrive800-03 series 03A8.....	106
7.8 Goodrive800 series control cabinet.....	107
7.9 Goodrive800 series engineering IP20 standard cabinet.....	108
7.9.1 400mm standard cabinet.....	108
7.9.2 600mm standard cabinet.....	109
7.9.3 800mm standard cabinet.....	110
7.9.4 1000mm standard cabinet.....	111
7.9.5 1200mm standard cabinet.....	112
7.10 Goodrive800 series control unit.....	113
7.11 Goodrive800 series keypad.....	114
Chapter 8 Peripheral options.....	115
8.1 Optional card.....	115
8.1.1 IO extension card (reserved).....	115
8.1.2 Communication extension card.....	115
8.1.3 PG extension card.....	120
8.1.4 RST signal detection board.....	125
8.1.5 Temperature detection board.....	125

Chapter 1 Safety precautions

Please read this manual carefully and follow all safety precautions before moving, installing, operating and servicing the inverter. If ignored, physical injury or death may occur, or damage may occur to the devices.

If any physical injury or death or damage to the devices occurs for ignoring to the safety precautions in the manual, our company will not be responsible for any damages and we are not legally bound in any manner.

1.1 Safety definition

Danger: Serious physical injury or even death may occur if not follow relevant requirements.









Warning: Physical injury or damage to the devices may occur if not follow relevant requirements.

Note: Physical hurt may occur if not follow relevant requirements.

Qualified electricians: People working on the device should take part in professional electrical and safety training, receive the certification and be familiar with all steps and requirements of installing, commissioning, operating and maintaining the device to avoid any emergency.



1.2 Warning symbols

Warnings caution you about conditions which can result in serious injury or death and/or damage to the equipment, and advice on how to avoid the danger. Following warning symbols are used in this manual:

Symbols	Name	Instruction	Abbreviation
 Danger	Danger	Serious physical injury or even death may occur if not follow the relative requirements	
 Warning	Warning	Physical injury or damage to the devices may occur if not follow the relative requirements	
 Do not	Electrostatic discharge	Damage to the PCBA board may occur if not follow the relative requirements	
 Hot sides	Hot sides	Sides of the device may become hot. Do not touch.	
Note	Note	Physical hurt may occur if not follow the relative requirements	Note

1.3 Safety guidelines

	<ul style="list-style-type: none"> ◇ Only qualified electricians are allowed to operate the inverter. ◇ Do not carry out any wiring and inspection or changing components when the power supply is applied. Ensure all input power supply is disconnected before wiring and checking and always wait for at least the time designated on the inverter or until the DC bus voltage is less than 36V. Below is the table of the waiting time: 				
	<table border="1" style="width: 100%; border-collapse: collapse;"> <thead> <tr> <th style="width: 60%;">Voltage degree of Goodrive800 series products</th> <th style="width: 40%;">Minimum waiting time</th> </tr> </thead> <tbody> <tr> <td style="text-align: center;">380V</td> <td style="text-align: center;">15 minutes</td> </tr> </tbody> </table>	Voltage degree of Goodrive800 series products	Minimum waiting time	380V	15 minutes
	Voltage degree of Goodrive800 series products	Minimum waiting time			
380V	15 minutes				

	500V	
	660V	
	⚡ Do not refit Goodrive800 series products unauthorized; otherwise fire, electric shock or other injury may occur.	
	⚡ The base of the radiator may become hot during running. Do not touch to avoid hurt.	
	⚡ The electrical parts and components inside Goodrive800 series products are electrostatic. Take measurements to avoid electrostatic discharge during relevant operation.	

1.3.1 Delivery and installation

	<ul style="list-style-type: none"> ⚡ Use special tools to install and remove the unit. ⚡ Use crane to install the whole machine. ⚡ Do not install Goodrive800 series products on combustible materials and avoid them to contact any combustible materials. ⚡ Connect the optional parts and components (braking resistors, braking units and feedback units) according to the wiring diagram. ⚡ Prevent dumping in installation because the gravity of the unit is high. ⚡ Ensure that no other objects, such as screws, cable, left in the cabinet or Goodrive800 series products after installation or maintenance, otherwise damage may occur. ⚡ Do not operate if there is any damage or components loss. ⚡ Do not touch Goodrive800 series products with wet items or some part of the body, electric shock may occur.
---	--

Note:

- ⚡ Select appropriate moving and installing tools to ensure a safe and normal running of the inverter and avoid physical injury or death. For physical safety, the erector should take some mechanical protective measurements, such as wearing exposure shoes and working uniforms.
- ⚡ Ensure to avoid physical shock or vibration during delivery and installation.
- ⚡ Install away from children and other public places.
- ⚡ Goodrive800 series products cannot meet the requirements of low voltage protection in IEC61800-5-1 if the sea level of installation site is above 2000m.
- ⚡ The leakage current of Goodrive800 series products may be above 3.5mA during operation.
- ⚡ The conductivity of PE grounding conductor is the same as that of the phase conductor (with the same cross sectional area).

Cross-sectional area of conductor power cord (mm ²)	Cross-sectional area of grounding conductor (mm ²)
S≤16	S
16<S≤35	16
35<S	S/2

1.3.2 Time and sequence when power on/off

Time and sequence when power on:

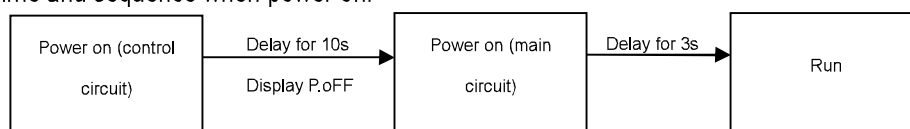

Time and sequence when power off:

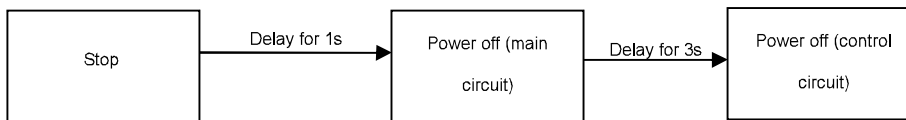

1.3.3 Commissioning and running

	<ul style="list-style-type: none"> ✧ Disconnect all power supplies applied to Goodrive800 series products before the terminal wiring and wait for at least the designated time after disconnecting the power supply. ✧ Check the connection of cable before power on. ✧ If the auxiliary control power of Goodrive800 series products is provided by external device, all power supplies are not disconnected. Check according to the diagram because voltage may be present when the device is not started, otherwise physical injury may occur. ✧ The operator can not touch the electrical parts in the cabinet directly. Pay attention when process the metal shield. ✧ Do not carry out any withstand voltage test in unit connection. Disconnect the motor cable before any isolation or withstand voltage test to the motor or motor cable. ✧ High voltage is present inside the product during running. Do not open the cabinet door. ✧ The inverter may start up by itself when P01.21=1. Do not get close to the product and motor. ✧ Voltage is also present on the motor terminals even if the motor does not rotate. ✧ “E-stop” of the device is for the disconnection of input power supply but not for the use of “E-stop device” . ✧ The device can not be used to break the motor suddenly. A mechanical braking device should be provided. ✧ Follow below precautions: <ol style="list-style-type: none"> 1. All input power supplies are disconnected (including the main and control power supply). 2. Permanent magnet synchronous motor has stopped and the measured output voltage of Goodrive800 series products is less than 36V. 3. The waiting time after permanent magnet synchronous motor stopping is no less than the designated time on Goodrive800 series products and the measured voltage between (+) and (-) is less than 36V. 4. Ensure the motor does not rotate again during operation. It is recommended to install external braking devices or switch off the direct electrical connection between permanent magnet synchronous motor and Goodrive800 series products.
---	---

Note:

- ✧ Do not switch on or off the input power supply of Goodrive800 series products frequently.
- ✧ For Goodrive800 series products that have been stored for a long time, check and fix the capacitance and try to run it again before utilization (see Installation and Maintenance Manual).
- ✧ Cover the cabinet door before running, otherwise electric shock may occur.

1.3.3 Maintenance and replacement of components

	<ul style="list-style-type: none"> ✧ Only qualified electricians are allowed to perform the maintenance, inspection, and components replacement of Goodrive800 series products. ✧ Disconnect all power supplies to Goodrive800 series products before the terminal wiring. Wait for at least the time designated on Goodrive800 series products after disconnection. ✧ Take measures to avoid screws, cables and other conductive matters to fall into Goodrive800 series products during maintenance and component replacement. ✧ Operating optical fiber should be very careful. Do not touch the plug fiber optic fiber, because ✧ Operate the optical fiber carefully. Do not touch the conduction-section (glass fiber) when plugging and inserting, because the fiber optic section (glass fiber) is extremely sensitive to dirt. The minimum bend radius of the optical fiber is 35 mm.
---	---

Note:

- ✧ Please select proper torque to tighten screws.
- ✧ Keep the inverter, parts and components away from combustible materials during maintenance and component replacement.
- ✧ Do not carry out any isolation and voltage test on the inverter and do not measure the control circuit of the inverter by megameter.
- ✧ Take right measures to avoid static electric for the product or internal parts and components during the maintenance and replacement.

1.3.4 What to do after scrapping

	<ul style="list-style-type: none"> ✧ There are heavy metals in Goodrive800 series products. Deal with it as industrial effluent.
---	---

1.4 Precautions of installation and applications

1.4.1 Do not connect the output of inverter to capacitor

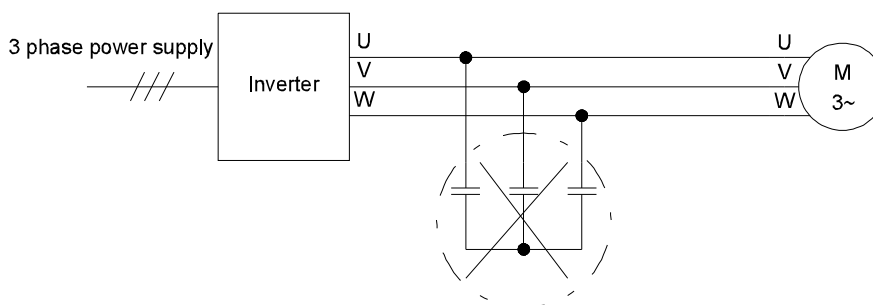

1.4.2 Cable requirements of parallel connection (inverters or power units)

Connection 1: the output cables are converged to the motor and the cables between the inverter and the motor have same length, cross section and model.

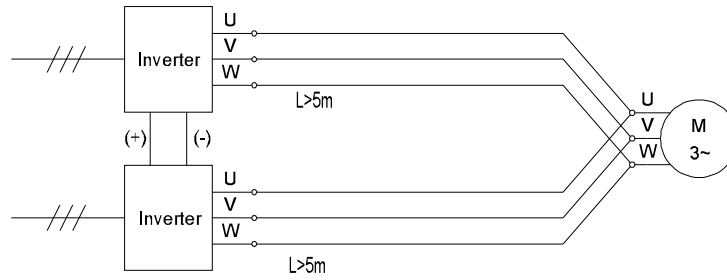

Connection 2: the output cables are converged to the sinusoidal filter.

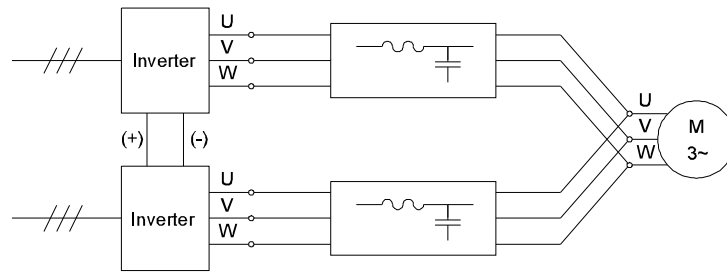

Wrong connection: the output cables are converged at the inverter side and the cables length between the inverter and the motor is different.

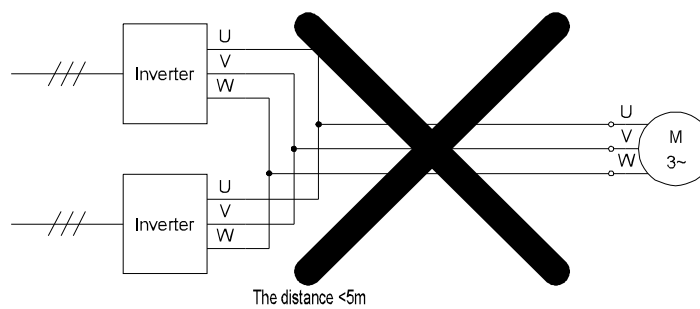
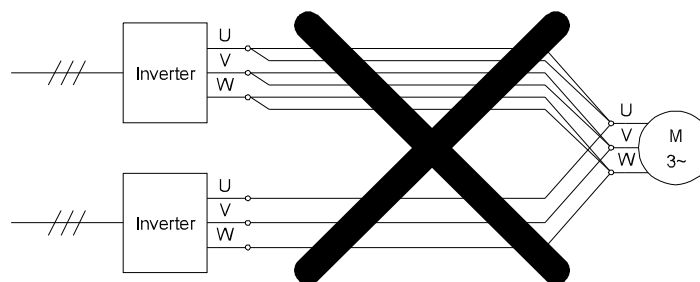
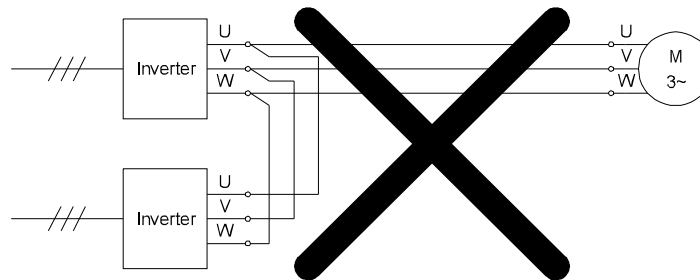

Chapter 2 Application precautions

2.1 Inspection before power on

2.1.1 Unpacking inspection

Check as followings after receiving products:

1. Check that there are no damage and humidification to the package.
2. Check the information on the type designation label on the outside of the package to verify that the drive is of the correct type.
3. Check that there are no signs of water in the package and no signs of damage or breach to the inverter.
4. Check the information on the type designation label on the outside of the package to verify that the name plate is of the correct type.
5. Check to ensure the accessories (including user's manual, control keypad and extension card) inside the device is complete.

If any problem, please contact with local dealers or INVT offices.

2.1.2 Application confirmation

Check the machine before beginning to use the product:

1. Check the load type to verify that there is no overload of Goodrive800 series products during work and check that whether the drive needs to modify the power degree.
2. Check the product meets the requirements of the communication mode.
3. Check the grid voltage is in the allowable input voltage range of Goodrive800 series products.
4. Check that the actual current of the motor is less than the rated current of Goodrive800 series products.

2.1.3 Environment

Check as followings before the actual installation and usage:

1. Check that the ambient temperature of Goodrive800 series products is below 40°C. If exceeds, derate 3% for every additional 1°C. Additionally, Goodrive800 series products can not be used if the ambient temperature is above 50°C.
2. Check that the ambient temperature of Goodrive800 series products in actual usage is above -10°C. If not, add heating facilities.
3. Check that the altitude of the actual usage site is below 1000m. If exceeds, derate 1% for every additional 100m.
4. Check that the humidity of the actual usage site is below 90% and condensation is not allowed. If not, add additional protection inverters.
5. Check that the actual usage site is away from direct sunlight and foreign objects can not enter Goodrive800 series products. If not, add additional protective measures.
6. Check that there is no conductive dust or flammable gas in the actual usage site. If not, add additional protection to inverters.

2.1.4 Installation confirmation

Check as followings after the installation:

1. Check that the input and output cables meet the need of actual load.
2. Check that the accessories of Goodrive800 series products are correctly and properly installed. The installation cables should meet the needs of every component (including reactors, input filters, output reactors, output filters, DC reactors, braking units and braking resistors).

3. Check that Goodrive800 series product is installed on non-flammable materials and the calorific accessories (reactors and brake resistors) are away from flammable materials.
4. Check that all control cables and power cables are run separately and the routation complies with EMC requirement.
5. Check that all grounding systems are properly grounded according to the requirements of Goodrive800 series products.
6. Check that the free space during installation is sufficient according to the instructions in user's manual.
7. Check that the external connection terminals are tightly fastened and the torque is appropriate.
8. Check that there are no screws, cables and other conductive items left in Goodrive800 series products.

2.2 Environmental requirements of the product

Refer to *Installation and Maintenance Manual for Goodrive800 series products*.

Installation site is important to the application and maintenance of Goodrive800 series products; please select the installation site according to followings:

Environmental conditions		Standards
Operation environment	Installation site	Install the drive system vertically on the indoor base; Outlet/inlet \geq 10cm; Distance between the cabinet and walls or other obstacle \geq 5 cm; The cooling medium is air.
	Ambient temperature	-10°C~50°C, Changes of air temperature \leq 0.5°C /min; Derate if the temperature is above 40°C; Max. temperature: 50°C
	Relative humidity	5%~95%
	Other climatic conditions	No condensation, freezing rain, snow and hail; Solar radiation \leq 700W/m ² ; Barometric pressure 70~106kPa
	Salt spray and corrosive gas content	Pollution degree 2
	Dirt and solid particle content	Pollution degree 2
	Altitude	\leq 1000m; Derate if the altitude is above 1000m; Derate 1% for every additional 100m
	Vibration	Maximum amplitude \leq 5.8m/s ² (0.6g)
Storage environment	Storage site	Clean and dry
	Ambient temperature	-30°C ~60°C; Changes of air temperature \leq 1 °C/min
	Relative humidity	5%~95%
	Storage time	\leq 6 months
Transportation environment	Transportation tools	Automobiles, trains, ships are available for standard package
	Ambient temperature	-30°C ~60°C

Environmental conditions		Standards
	RH	≤95% at 40°C
	Vibration	15m/s ² (1.5g) at sinusoidal vibration 9~200Hz

2.3 Derating of Goodrive800 series products

2.3.1 Capacity

Inverter sizing is based on the rated motor current and power. To achieve the rated motor power given in the table, the rated current of Goodrive800 series products must be higher than or equal to the rated motor current. Also the rated power of Goodrive800 series products must be higher than or equal to the rated motor power. The power ratings are the same regardless of the supply voltage within one voltage range.

Note:

1. The maximum allowed motor shaft power is limited to 1.5*PN. If the limit is exceeded, motor torque and current are automatically restricted. The function protects the input bridge of the drive against overload.
2. The ratings apply at ambient temperature of 40 °C
3. It is important to check that in common DC systems the power flowing through the common DC connection does not exceed PN.

2.3.2 Derating

The load capacity decreases if the installation site ambient temperature exceeds 40 °C, the altitude exceeds 1000 meters or the carrier frequency exceeds the default value.

2.3.2.1 Temperature derating

In the temperature range +40°C~+50°C, the rated output current is decreased by 2% for every additional 1 °C. Refer to the below list for the actual derating.

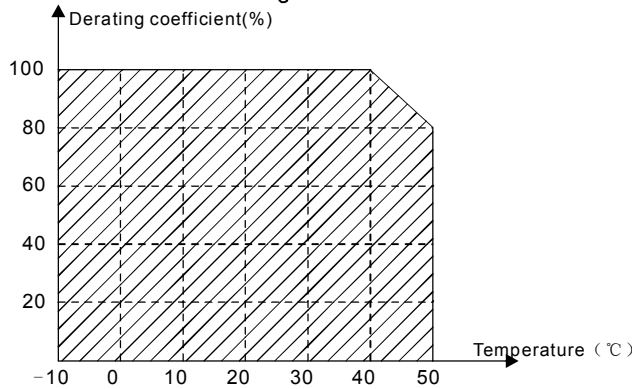

It is not recommended to use the inverter when the temperature is above 50 °C.

2.3.2.2 Altitude derating

The device can output at rated power if the installation site below 1000m. The output power decreases if the altitude exceeds 1000 meters. Below is the detailed decreasing range of the derating:

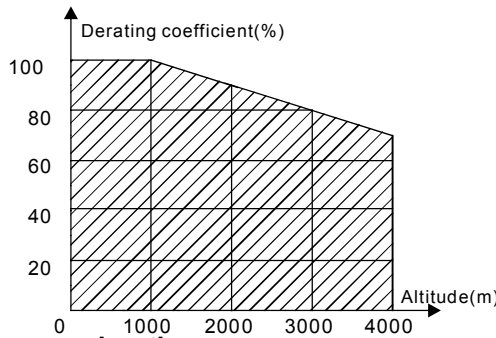

2.3.2.3 Carrier frequency derating

Different Goodrive800 series products have different carrier frequency. The rated power is based on the factory carrier frequency, and if the value exceeds the setting range, Goodrive800 series products need to derate 10% for every additional 1kHz.

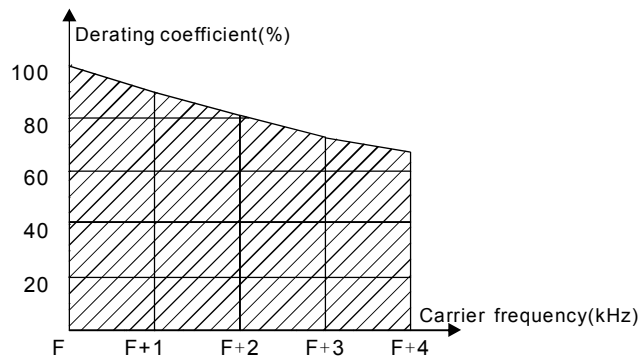

2.4 Application standards

Goodrive800 series products follow:

EN/ISO 13849-1:2008	Machinery Safety - The safety-related parts of control systems - Part 1: General principles for design
IEC/EN 60204-1:2006	Machinery Safety - The electrical equipment of the machine - Part 1: General requirements
IEC/EN 62061:2005	Machinery Safety-Functional safety of the safety-related electrical, electronic and programmable electronic control system
IEC/EN 61800-3:2004	Adjustable speed electrical drive systems. Part 3: EMC standards and specific test of EMC adjustable speed electrical power drive systems
IEC/EN 61800-5-1:2007	Adjustable speed electrical drive systems-Part 5-1:Safety requirements - electrical, thermal and energy
IEC/EN 61800-5-2:2007	Adjustable speed eelectrical drive systems- Part 5-2: Safety requirements - functional

2.4.1 CE mark

The CE mark is attached to the drive to verify that the drive follows the provisions of the European Low Voltage (2006/95/EC) and EMC Directives (2004/108/EC).

2.4.2 Compliance with the European EMC Directive

The EMC Directive defines the requirements for immunity and emissions of electrical equipment used within the European Union. The EMC product standard (EN 61800-3:2004) covers requirements stated for drives. See section EMC regulations.

2.5 EMC regulations

EMC product standard (EN 61800-3:2004) contains the EMC requirements to the inverter.

First environment: domestic environment (includes establishments connected to a low-voltage network which supplies buildings used for domestic purposes).

Second environment includes establishments connected to a network not directly supplying domestic premises.

Four categories of the inverter:

Inverter of category C1: inverter of rated voltage less than 1000 V and used in the first environment.

Inverter of category C2: inverter of rated voltage less than 1000 V other than pins, sockets and motion devices and intended to be installed and commissioned only by a professional electrician when used in the first environment.

Inverter of category C3: inverter of rated voltage less than 1000 V and used in the second environment other than the first one

Inverter of category C4: inverter of rated voltage more than 1000 V or the nominal current is above or equal to 400A and used in the complicated system in second environment

Note: IEC/EN 61800-3 in EMC standard doesn't limit the power distribution of the inverter, but it defines the usage, installation and commission. The professional electrician has necessary skills in installing and/or commissioning power drive systems, including their EMC aspects.

2.5.1 Category C2

The emission limits are complied with the following provisions:

1. The optional EMC filter is selected according to the options and installed as specified in the EMC filter manual.
2. The motor and control cables are selected as specified in this manual.
3. The drive is installed according to the instructions given in this manual.



In the domestic environment, this product may cause radio interference, in which case supplementary mitigation measures may be required.

2.5.2 Category C3

The immunity performance of the drive complies with the demands of IEC/EN 61800-3, second environment.

The emission limits are complied with the following provisions:

1. The optional EMC filter is selected according to the options and installed as specified in the EMC filter manual.
2. The motor and control cables are selected as specified in this manual.
3. The drive is installed according to the instructions given in this manual.



A drive of category C3 is not intended to be used on a low-voltage public network which supplies domestic premises. Radio frequency interference is expected if the drive is used on such a network.

Chapter 3 Technical parameters

3.1 Product name plate

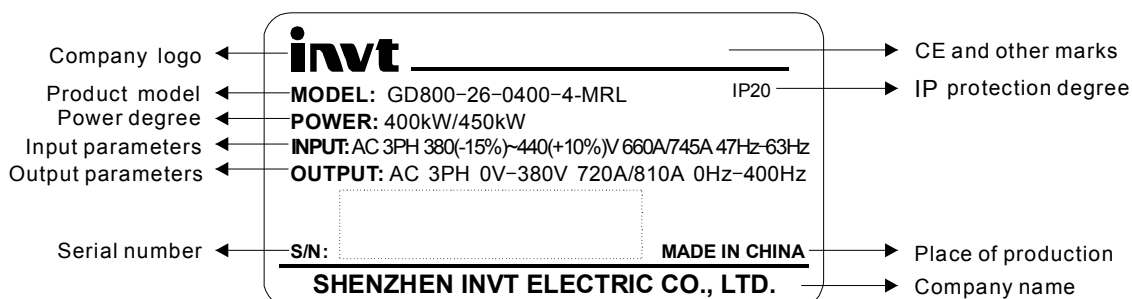

Note: CE mark is only present on the corresponding position if pass the CE certification.

3.2 Product model and name

3.2.1 Model of Goodrive800 series products

GD 800 - 2 6 - 0400 - 4 - MRL
 ① ② ③ ④ ⑤ ⑥ ⑦

Descriptions:

Key	No.	Instruction	Example
Product series	①	Product series	GD: Goodrive series inverters
Product name	②	Series name	300: Common inverters 800: Engineering drive products
	③	Product type	1: Two-quadrant variable frequency drive 2: Four-quadrant variable frequency drive 5: Convertering 6: Diode rectification 7: Silicon-controller rectification 8: IGBT synchronous rectification 9: IGBT PWM rectification
	④	Structure type	1: Unit products 2: Standard drive products 6: Cabinet products (IP20) 8: Cabinet products (IP54)
Power degree	⑤	Power degree	Refer to the electric parameters definition of each unit for the definition of the power code
Voltage degree	⑥	Voltage degree	4: AC 3PH 380V (-15%)~440V(+10%) 5: AC 3PH 380V (-10%)~550V(+10%) 6: AC 3PH 520V (-15%)~690V(+10%)
Lot number	⑦	Lot number	MLR: Multiple cabinet products from left to right: switching cabinet → filter rectification cabinet → convertering cabinet;

			MRL: Multiple cabinet products from right to left: convertering cabinet← filter rectification cabinet← switching cabinet; MSC: Single cabinet products (default)
--	--	--	---

3.2.2 Model of Goodrive800 control unit

GD800 – ICU – 0400 – 4

① ② ③ ④

Key	Sign	Instruction	Example
Product series	①	Product series	GD: Goodrive series inverters
Product name	②	Product name	300: Common inverters 800: Engineering drive products
	③	Control unit type	RCU: PWM rectification control unit ICU: inverter control unit
Power code	④	Power code	Refer to the electric parameters definition of each unit for the definition of the power code
Voltage degree	⑤	Voltage degree	4: AC 3PH 380V (-15%)~440V(+10%) 5: AC 3PH 380V (-10%)~550V(+10%) 6: AC 3PH 520V (-15%)~690V(+10%)

3.2.3 Model of Goodrive800 optional unit

Key	Sign	Instruction	Example
Product series	①	Product series	GD: Goodrive series inverters
Product name	②	Product name	300: Common inverters 800: Engineering drive products
	③	Control unit type	01: LCL PWM rectification filter unit 02: Sina wave filter unit 03: Bus capacitor energy storage/ filter unit
Power code	④	Power code	Refer to the electric parameters definition of each unit for the definition of the power code
Voltage degree	⑤	Voltage degree	4: AC 3PH 380V (-15%)~440V(+10%) 5: AC 3PH 380V (-10%)~550V(+10%) 6: AC 3PH 520V (-15%)~690V(+10%)

3.2.4 Product name of Goodrive800 series models

3.2.4.1 Product name of Goodrive800 series models

Product name	Series name	Name	Voltage degree	Power range
Unit product	Goodrive800-11	Inverter unit	380	4~400
			500	4~400
			660	22~500
	Goodrive800-51	IGBT unit	380	37~400
			500	37~400
			660	75~500
Goodrive800-61	Diode rectifier unit	380	132~400	

Product name	Series name	Name	Voltage degree	Power range
			500	132~400
			660	132~500
	Goodrive800-71	Silicon-controlled rectifier unit	380	400~600
			500	400~600
			660	630~1000
	Goodrive800-81	IGBT synchronous rectifier unit	380	75~400
			500	75~400
			660	75~500
	Goodrive800-91	Simple PWM rectification unit	380	37~400
			500	37~400
			660	75~500
Standard cabinet product	Goodrive800-16	Cabinet inverter	380	75~1200
			500	75~1200
			660	75~1500
	Goodrive800-26	Four-quadrant cabinet inverter	380	75~2400
			500	75~2400
			660	75~3000
	Goodrive800-56	Cabinet converter	380	75~2400
			500	75~2400
			660	75~3000
	Goodrive800-66	Cabinet diode rectifier	380	132~1200
			500	132~1200
			660	132~1500
	Goodrive800-76	Cabinet SCR rectifier	380	200~2400
			500	200~2400
			660	200~3000
	Goodrive800-86	Cabinet IGBT synchronous rectifier	380	75~1200
			500	75~1200
			660	75~1500
	Goodrive800-96	Cabinet IGBT PWM rectifier	380	75~2400
			500	75~2400
			660	75~3000

3.2.4.2 Product name of Goodrive800 series models (optional)

Product name	Series name	Name	Voltage degree	Power range	
Unit product	Goodrive800-01	LCL PWM rectification filter unit	380	250~400	
			500	250~400	
			660	315~500	
	Goodrive800-02	Sine wave filter unit	380	250~400	
			500	250~400	
			660	315~500	
			Bus capacitor energy storage/ filter unit	380	250~400

Product name	Series name	Name	Voltage degree	Power range
	Goodrive800-03		500	250~400
			660	315~500

3.2.5 Products comparison

Model	Goodrive800-01	Goodrive800-11	Goodrive800-51	Goodrive800-61	Goodrive800-71	Goodrive800-81
Name	LCL PWM filter unit	Inverter unit	Converting (power) unit	Diode rectification unit	Silicon-controller rectification unit	IGBT synchronous rectification unit
Features	<ol style="list-style-type: none"> 1. includes the inlet filter reactor, damping resistor, capacitor unit and the rectification reactor 2. important part of GD800-26 and 96 series 	<ol style="list-style-type: none"> 1. includes diode rectification and IGBT converting 2. be used with control unit 3. important part of GD800-16 	<ol style="list-style-type: none"> 1. be used as rectification unit and converting unit 2. be used with control unit 3. be parallel-connected, important part of GD800-26, 96 and 56 	<ol style="list-style-type: none"> 1. diode rectification, the bus voltage can be adjusted 2. no energy feedback 3. support 6 pulse and 12 pulse input 4. support AC and DC buffer buffer 	<ol style="list-style-type: none"> 1. silicon-controlled and diode rectification, the bus voltage can be adjusted 2. no energy feedback 3. silicon-controlled phase-shift buffer, no electricity buffer contactor 	<ol style="list-style-type: none"> 1. IGBT rectification, the bus voltage can be adjusted 2. with energy feedback 3. to be equipped with communication buffer contactor 4. to be equipped with pressure drop of 4% AC reactor
Cooling	Internal forced air cooling	Internal forced air cooling	Internal forced air cooling	Internal forced air cooling	Internal forced air cooling	Internal forced air cooling

Model	Goodrive800-16	Goodrive800-26	Goodrive800-56	Goodrive800-66	Goodrive800-76	Goodrive800-86	Goodrive800-96
Name	Cabinet inverter	Four quadrant cabinet inverter	Cabinet converter	Cabinet diode rectifier	Cabinet silicon controlled rectifier	Cabinet IGBT synchronous rectifier	Cabinet IGBT PWM rectifier
Features	<ol style="list-style-type: none"> 1. diode rectification, the bus voltage can be adjusted 2. no energy feedback 	<ol style="list-style-type: none"> 1. includes PWM rectifier and converter 2. with energy feedback and the bus voltage can be adjusted 	<ol style="list-style-type: none"> 1. independent control unit 2. flexible configuration 3. mainly for DC bus and can be connect to 66, 76, 86 and 96 	<ol style="list-style-type: none"> 1. diode rectification, the bus voltage can be adjusted 2. no energy feedback 3. contactor buffer 	<ol style="list-style-type: none"> 1. silicon-controlled and diode rectification, the bus voltage can be adjusted 2. no energy feedback 3. silicon-controlled phase-shift buffer, no electricity buffer contactor 	<ol style="list-style-type: none"> 1. IGBT rectification, the bus voltage can be adjusted 2. with energy feedback 3. to be equipped with AC buffer contactor 	<ol style="list-style-type: none"> 1. IGBT rectification, the bus voltage can be adjusted 2. with energy feedback 3. to be equipped with AC buffer contactor
Cooling	Internal forced air cooling	Internal forced air cooling	Internal forced air cooling	Internal forced air cooling	Internal forced air cooling	Internal forced air cooling	Internal forced air cooling
Power factor	>92% (with external AC reactor 4%)	>98%, >99% at full load	>92%(with external AC input reactor 4% at the rated load)	>92%(with external AC input reactor 4% at the rated load)	>92%(with external AC input reactor 4% at the rated load)	>92%(with external AC input reactor 4% at the rated load)	>98%, >99% at full load

3.3 Product specifications

3.3.1 Product specifications of Goodrive800-51 series power unit

Function		Specifications
Power ratings	DC voltage (V)	380V: DC350V~800V 500V: DC450V~1000V 660V: DC570V~1200V
	Rated input current(V)	Refer to 3.4.2
	Rated output voltage(V)	0~0.7V _{DC}
	Rated output current(A)	Refer to 3.4.2
	Rated output power(kW)	Refer to 3.4.2
	Rated input efficiency (%)	98%
	Output frequency (Hz)	0~400Hz
Operation control	Current limit	Max. value: 200% of the rated current
	Carrier frequency	1~8kHz
	Bus voltage detection accuracy	Overvoltage point $\pm 1\%$
	The output current detection accuracy	Rated current $\pm 3\%$
Protections	Overload protection	150% of rated current:60s, 180% of rated current:10s, 200% of rated current:1s
	Overvoltage protection	380V: bus 800V overvoltage 500V: bus 1000V overvoltage 660V: bus 1200V overvoltage
	Overtemperature protection	85°C
	Fault protection	About 20 unit fault protections
Others	Audio noise	<75dB
	Installation mode	Cabinet installation
	Protection degree	IP00
	Cooling mode	Forced air cooling
	Safety and EMC performance	Meet CE requirement

Note: No standard control units. It can be used as an inverter with ICU control units and as PWM rectifiers with RCU control units.

3.3.2 Product specifications of Goodrive800-11 series inverter unit

Function		Specifications
Power input	Rated input voltage(V)	AC 3PH 380V (-15%)~440V(+10%) AC 3PH 380V (-10%)~550V(+10%) AC 3PH 520V (-15%)~690V(+10%)
	Rated input current(A)	Refer to 3.4.1
	Rated input frequency(Hz)	50Hz/60Hz, 47~63Hz
	Rated input efficiency (%)	≥97%
Power output	Rated output voltage(V)	0~input voltage
	Rated output current(A)	Refer to 3.4.1
	Rated output power(kW)	Refer to 3.4.1
	Rated output frequency(Hz)	0~400Hz
Operation control	Current limit	Max. value: 200% of the rated current
	Carrier frequency	1~8kHz
	Bus voltage detection accuracy	Overvoltage point ±1%
	The output current detection accuracy	Rated current ±3%
Protections	Motor protection	Motor overload and overtemperature protection
	Overcurrent protection	150% of rated current:60s, 180% of rated current:10s, 200% of rated current:1s
	Overvoltage protection	380V: bus 800V overvoltage 500V: bus 1000V overvoltage 660V: bus 1200V overvoltage
	Undervoltage protection	380V: bus 350V undervoltage 500V: bus 450V overvoltage 660V: bus 570V overvoltage
	Overtemperature protection	85℃
	Fault protection	About 20 unit fault protections
Others	Audio noise	<75dB
	Installation mode	Cabinet installation
	Protection degree	IP00
	Cooling mode	Forced air cooling
	Safety and EMC performance	Meet CE requirement

Note: No standard control units. It can be used as an inverter with ICU control units.

3.3.3 Product specifications of Goodrive800-61 diode rectification unit

Function		Specifications
Power input	Rated input voltage(V)	AC 3PH 380V (-15%)~440V(+10%) AC 3PH 380V (-10%)~550V(+10%) AC 3PH 520V (-15%)~690V(+10%)
	Rated input current(A)	Refer to 3.4.3
	Rated input frequency(Hz)	50Hz/60Hz, 47~63Hz
	Rated input efficiency (%)	≥97%
	Rated input power factor	≥98%
Operation control	Current limit	Max. value: 200% of the rated current
	Carrier frequency	2~8kHz
	Bus voltage detection accuracy	Overvoltage point ±1%
	The output current detection accuracy	Rated current ±3%
Protections	Motor protection	Motor overload and overtemperature protection
	Overcurrent protection	150% of rated current:60s, 180% of rated current:10s, 200% of rated current:1s
	Overvoltage protection	380V: bus 800V overvoltage 500V: bus 1000V overvoltage 660V: bus 1200V overvoltage
	Undervoltage protection	380V: bus 350V undervoltage 500V: bus 450V overvoltage 660V: bus 570V overvoltage
	Overtemperature protection	85℃
	Fault protection	About 20 unit fault protections
Others	Audio noise	<90dB
	Installation mode	Cabinet installation
	Protection degree	IP00
	Cooling mode	Forced air cooling
	Safety and EMC performance	Meet CE requirement

3.3.4 Product specifications of Goodrive800-16 inverter unit

Function		Specifications
Power input	Rated input voltage(V)	AC 3PH 380V (-15%)~440V(+10%) AC 3PH 380V (-10%)~550V(+10%) AC 3PH 520V (-15%)~690V(+10%)
	Rated input current(A)	Refer to 3.4.1
	Rated input frequency(Hz)	50Hz/60Hz, 47~63Hz
	Rated input efficiency (%)	≥97%
Power output	Rated output voltage(V)	0~input voltage
	Rated output current(A)	Refer to 3.4.1
	Rated output power(kW)	Refer to 3.4.1
	Rated output frequency(Hz)	0~400Hz
Operation control	Current limit	Max. value: 200% of the rated current
	Carrier frequency	1~8kHz
	Bus voltage detection accuracy	Overvoltage point ±1%
	The output current detection accuracy	Rated current ±3%
Protections	Motor protection	Motor overload and overtemperature protection
	Overcurrent protection	150% of rated current:60s, 180% of rated current:10s, 200% of rated current:1s
	Overvoltage protection	380V: bus 800V overvoltage 500V: bus 1000V overvoltage 660V: bus 1200V overvoltage
	Undervoltage protection	380V: bus 350V undervoltage 500V: bus 450V overvoltage 660V: bus 570V overvoltage
	Overtemperature protection	85℃
	Fault protection	About 20 unit fault protections
Others	Audio noise	<75dB
	Installation mode	Cabinet installation
	Protection degree	IP00
	Cooling mode	Forced air cooling
	Safety and EMC performance	Meet CE requirement

3.3.5 Product specifications of Goodrive800-26 series four-quadrant cabinet inverter

Function		Specifications
Power input	Rated input voltage(V)	AC 3PH 380V (-15%)~440V(+10%) AC 3PH 380V (-10%)~550V(+10%) AC 3PH 520V (-15%)~690V(+10%)
	Rated input current(A)	Refer to 3.4.4
	Rated input frequency (Hz)	50Hz/60Hz, range: 47~63Hz
	Rated input efficiency (%)	>95%
	Rated input power factor (%)	>98%
	Rated input current harmonic (%)	<5%
Power output	Rated output voltage(V)	0~1.15*input voltage, up to 0.7V _{DC}
	Rated output current(A)	Refer to 3.4.4
	Rated output power(kW)	Refer to 3.4.4
	Rated output frequency(Hz)	0~400Hz
Operation control	Control mode	SVPWM, close-loop vector and open-loop vector
	Carrier frequency	1-8 kHz
	Speed range	Close-loop vector : 1:1000 Open-loop vector : 1:100
	Speed control accuracy	Close-loop vector: ± 0.1% of the Max. speed Open-loop vector: ± 0.5% of the Max. speed
	Current limit	Max. value: 200% of the rated current
	The parallel uneven flow degrees of the power unit	≤5% of the unit rated current
	The parallel uneven flow degrees of the system	≤5% of the system rated current
	Bus voltage detection accuracy	Overvoltage point ±1%
	The output current detection accuracy	Rated current ±3%
	The terminal analog input resolution	≤20mV
The terminal switch input resolution	≤2ms	
Protections	Overload protection	150% of rated current:60s, 180% of rated current:10s, 200% of rated current:1s
	Overvoltage protection	380V: bus 800V overvoltage 500V: bus 1000V overvoltage 660V: bus 1200V overvoltage

Function		Specifications
	Undervoltage protection	380V: bus 350V undervoltage 500V: bus 450V overvoltage 660V: bus 570V overvoltage
	Overtemperature protection	85°C
	Fault protection	More than 30 fault protections and 20 unit fault protections
	Safety protection	STO, SS1, SSL, SBC protections
Others	Audio noise	<90dB
	Installation mode	Floor installation
	Protection degree	IP20
	Cooling mode	Forced air cooling
	Safety and EMC performance	Meet CE requirement

3.3.6 Product specifications of Goodrive800-56 series standard IGBT cabinet

Function		Specifications
Power input	Input voltage (V)	380V: DC350V~800V 500V: DC450V~1000V 660V: DC570V~1200V
	Rated input current(A)	97%
	Rated input current harmonic (A)	<5%
Power output	Output voltage (V)	0~0.7V _{DC}
	Rated output current(A)	Refer to 3.4.5
	Rated output power(kW)	Refer to 3.4.5
	Output frequency (Hz)	0~400Hz
Operation control	Current mode	SVPWM, close-loop vector and open-loop vector
	Carrier frequency	1~8kHz
	Speed ratio	Close-loop vector: 1:1000 Open-loop vector: 1:100
	Speed control accuracy	Close-loop vector: $\pm 0.1\%$ of the Max. speed Open-loop vector: $\pm 0.5\%$ of the Max. speed
	Current limit	Max. value: 200% of the rated current
	The parallel uneven flow degrees of the power unit	$\leq 5\%$ of the unit rated current
	The parallel uneven flow degrees of the system	$\leq 5\%$ of the system rated current
	Bus voltage detection accuracy	Overvoltage point $\pm 1\%$
	The output current detection accuracy	Rated current $\pm 3\%$
	The terminal analog input resolution	$\leq 20\text{mV}$
	The terminal switch input resolution	$\leq 2\text{ms}$
Protections	Overload protection	150% of rated current:60s, 180% of rated current:10s, 200% of rated current:1s
	Overvoltage protection	380V: bus 800V overvoltage 500V: bus 1000V overvoltage 660V: bus 1200V overvoltage
	Undervoltage protection	380V: bus 350V undervoltage 500V: bus 450V overvoltage 660V: bus 570V overvoltage
	Overtemperature protection	85°C
	Fault protection	More than 30 fault protections and 20 unit fault protections
Others	Audio noise	<80dB

Function		Specifications
	Installation mode	Floor installation
	Protection degree	IP20
	Cooling mode	Forced air cooling
	Safety and EMC performance	Meet CE requirement

3.3.7 Product specifications of Goodrive800-96 series cabinet IGBT PWM rectifier

Function		Specifications
Power input	Rated input voltage(V)	AC 3PH 380V (-15%)~440V(+10%) AC 3PH 380V (-10%)~550V(+10%) AC 3PH 520V (-15%)~690V(+10%)
	Rated input current(A)	Refer to 3.4.6
	Rated input frequency(Hz)	50Hz/60Hz, 47~63Hz
	Rated input efficiency (%)	≥97%
	Rated input power factor (%)	≥98%
Operation control	Current limit	Max. value: 200% of the rated current
	Carrier frequency	2~8kHz
	Bus voltage detection accuracy	±1% of the overvoltage point
	The input current detection accuracy	±3% of the rated current
Protections	Overload protection	150% of rated current:60s, 180% of rated current: 10s, 200% of rated current:1s
	Overvoltage protection	380V: bus 800V overvoltage 500V: bus 1000V overvoltage 660V: bus 1200V overvoltage
	Undervoltage protection	380V: bus 350V undervoltage 500V: bus 450V overvoltage 660V: bus 570V overvoltage
	Overtemperature protection	85℃
	Fault protection	More than 30 fault protections and 20 unit fault protections
Others	Audio noise	<90dB
	Installation mode	Floor installation
	Protection degree	IP20
	Cooling mode	Forced air cooling
	Safety and EMC performance	Meet CE requirement

3.3.8 Product specifications of Goodrive800-01 LCL PWM filter unit

Function		Specifications
Power input	Rated input voltage(V)	AC 3PH 380V (-15%)~440V(+10%) AC 3PH 380V (-10%)~550V(+10%) AC 3PH 520V (-15%)~690V(+10%)
	Rated input current(A)	Refer to 3.4.7
	Rated input frequency(Hz)	50Hz/60Hz, 47~63Hz
Whole performance	Voltage drop at grid	2%
	Voltage drop at rectifier	8%
Protections	Fault protection	Fault protection signal of the reactor overheating
Others	Audio noise	<90dB
	Installation mode	Cabinet installation
	Protection degree	IP00
	Cooling mode	Forced air cooling
	Safety and EMC performance	Meet CE requirement

3.3.9 Product specifications of Goodrive800 control unit

Function		Specifications
Operation power supply	Rated input voltage(V)	DC 24V±20%
	Rated input current(A)	DC 2A
Periphery Interface	10V power supply	10.5V reference power supply
	24V power supply	User power supply Max. output current: 200mA
	PW external power supply	Digital input/output operation power supply Voltage range:12~24V
	The terminal analog input resolution	≤20mV
	The terminal switch input resolution	≤20ms
	Analog input	2 (AI1,AI2) 0~10V/0~20mA 1(AI3) -10V~10V
	Analog output	1 (AO1)0~10V/0~20mA 1(AO2) -10V~10V/-20mA~20mA
	Digital input	8 (S1~S8) common input; Max. frequency: 1kHz; internal impedance:3.3k S8 can be used as common input and high speed input; Max. frequency: 50kHz
	Digital output	1 (Y1)Y Terminal open collector output, switching capacity:200mA/30V 1 (Y2) High-speed pulse output, output frequency 0~50k, switching capacity 1A/30V
	Relay output	4 programmable relay outputs: RO1A NO, RO1B NC, RO1C common terminal RO2A NO, RO2B NC, RO2C common terminal RO3A NO, RO3B NC, RO3C common terminal RO4A NO, RO4B NC, RO4C common terminal Contact capacity:3A/AC250V, 1A/DC30V Relay 4 can be used as the braking output terminal if the braking function is enabled, as well as the common relay.
	Safety terminal input	H1 and H2 is default to short-connect to COM terminal in STO safety terminal input. It is necessary to remove the connection wires between H1 and COM, H2 and COM; If PW applies external power supply, H1 and H2 need to short-connected with external power supply ground.
Communication	485 communication, apply MODBUS protocol	
Fiber-optic communications interface	Fiber optic port for parallel units	Up to 6 parallel power units
	Fiber optic port for master-slave communication	Support the system extension and power balance
Extension Interface	Communication interface	Support PROFIBUS, ETHERNET, CANopen and DEVICE-NET communication protocol through the optional communication cards
	PG card interface	Support incremental encoder, UVW encoder, sine and

Function		Specifications
		cosine encoder and resolver encoder through the optional PG cards
	Signal detection interface	Optional for temperature detection board, RST signal detection board and mains synchronous cards
	IO extension interface	Can be extended to digital and analog input/output
Others	Environment temperature	-10°C~50°C
	Installation mode	Wall mounting in cabinet
	Protection degree	IP00
	Cooling mode	Natural cooling
	Safety and EMC performance	Meet CE requirement

3.4 Main rated parameters

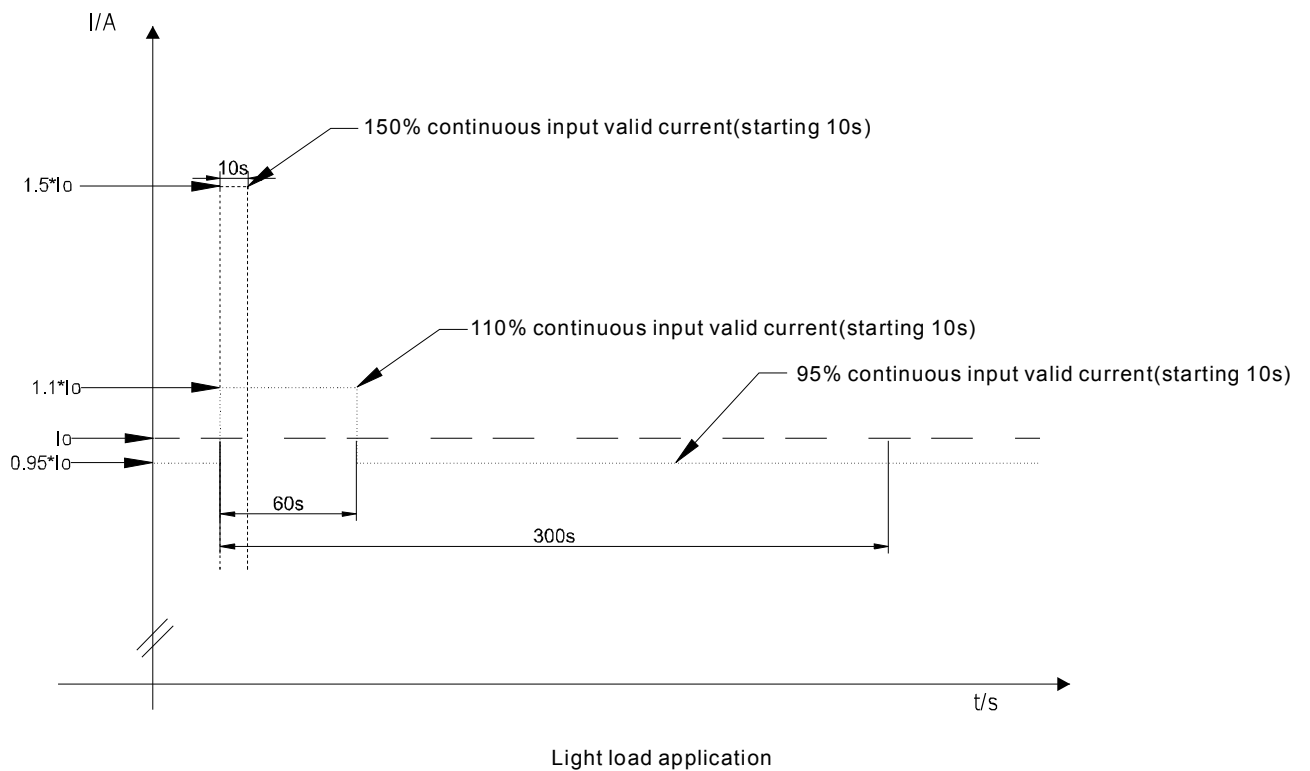
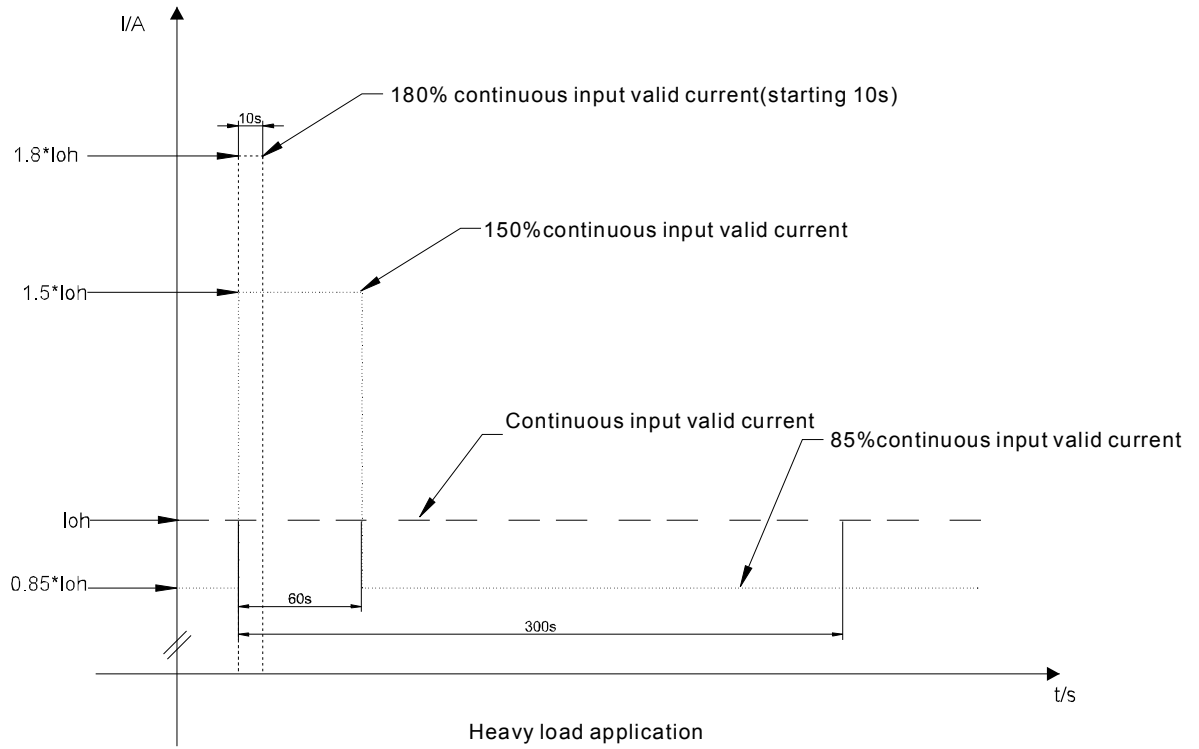

3.4.1 Main parameters of Goodrive800-11 inverter unit

Model	Heavy overload application			Light overload application			Air volume (m ³ /h)	Weight (kg)	Structure
	P _{Lh} (kW)	I _{lh} (A)	I _{oh} (A)	P _L (kW)	I _l (A)	I _o (A)			
U_N =380 V									
GD800-11-0004-4	4	13.5	9.5	5.5	19.5	14	45	3.5	11A1
GD800-11-05R5-4	5.5	19.5	14	7.5	25	18.5			
GD800-11-07R5-4	7.5	25	18.5	11	32	25	100	7	11A2
GD800-11-0011-4	11	32	25	15	40	32			
GD800-11-0015-4	15	40	32	18.5	47	38	180	8.5	11A3
GD800-11-0018-4	18.5	47	38	22	56	45			
GD800-11-0022-4	22	56	45	30	70	60	180	13	11A4
GD800-11-0030-4	30	70	60	37	80	75			
GD800-11-0037-4	37	80	75	45	94	92	240	23	11A5
GD800-11-0045-4	45	94	92	55	128	115			
GD800-11-0055-4	55	128	115	75	160	150	450	55	11A6
GD800-11-0075-4	75	160	150	90	190	180			
GD800-11-0090-4	90	190	180	110	225	215	600	100	11A7
GD800-11-0110-4	110	225	215	132	265	260			
GD800-11-0132-4	132	265	260	160	310	305	600	100	11A7
GD800-11-0160-4	160	310	305	185	360	355			
GD800-11-0200-4	200	385	380	220	430	425	1650	180	11A8
GD800-11-0250-4	250	485	480	285	545	530			
GD800-11-0315-4	315	610	600	350	625	650	600	120	11B7
GD800-11-0400-4	400	715	720	450	805	810			
GD800-11-0132-4-B	132	265	260	160	310	305	600	120	11B7
GD800-11-0160-4-B	160	310	305	185	360	355			
GD800-11-0200-4-B	200	385	380	220	430	425	800	160	11B8
GD800-11-0250-4-B	250	485	480	285	545	530			
GD800-11-0315-4-B	315	610	600	350	625	650	1400	450	11B9
GD800-11-0400-4-B	400	715	720	450	805	810			
U_N =500 V									
GD800-11-0004-5	4	11	8	5.5	15	10	100	7	11A2
GD800-11-05R5-5	5.5	15	10	7.5	19	14			
GD800-11-07R5-5	7.5	19	14	11	26	20	180	8.5	11A3
GD800-11-0011-5	11	26	20	15	32	26			
GD800-11-0015-5	15	32	26	18.5	40	34	240	23	11A5
GD800-11-0018-5	18.5	40	34	22	48	42			
GD800-11-0022-5	22	48	42	30	60	53	450	55	11A6
GD800-11-0030-5	30	60	53	37	66	63			
GD800-11-0037-5	37	66	63	45	78	75	450	55	11A6
GD800-11-0045-5	45	78	75	55	95	92			
GD800-11-0055-5	55	95	92	75	126	120	450	55	11A6
GD800-11-0075-5	75	126	120	90	155	150			
GD800-11-0090-5	90	155	150	110	180	175	450	55	11A6
GD800-11-0090-5	90	155	150	110	180	175			

Model	Heavy overload application			Light overload application			Air volume (m ³ /h)	Weight (kg)	Structure
	P _{Lh} (kW)	I _{lh} (A)	I _{oh} (A)	P _L (kW)	I _i (A)	I _o (A)			
GD800-11-0110-5	110	180	175	132	215	210	600	100	11A7
GD800-11-0132-5	132	215	210	160	265	255			
GD800-11-0160-5	160	265	255	185	285	290			
GD800-11-0200-5	200	315	325	220	340	350	1650	180	11A8
GD800-11-0250-5	250	380	395	285	410	425			
GD800-11-0315-5	315	495	510	350	525	545			
GD800-11-0400-5	400	600	620	450	645	665	600	120	11B7
GD800-11-0132-5-B	132	215	210	160	265	255			
GD800-11-0160-5-B	160	265	255	185	285	290			
GD800-11-0200-5-B	200	315	325	220	340	350	800	160	11B8
GD800-11-0250-5-B	250	380	395	285	410	425			
GD800-11-0315-5-B	315	495	510	350	525	545			
GD800-11-0400-5-B	400	600	620	450	645	665	1400	450	11B9
U_N =660 V									
GD800-11-0022-6	22	35	27	30	40	35	240	23	11A5
GD800-11-0030-6	30	40	35	37	47	45			
GD800-11-0037-6	37	47	45	45	55	52			
GD800-11-0045-6	45	55	52	55	65	62			
GD800-11-0055-6	55	65	62	75	85	86	450	55	11A6
GD800-11-0075-6	75	85	86	90	95	98			
GD800-11-0090-6	90	95	98	110	118	120			
GD800-11-0110-6	110	118	120	132	145	150			
GD800-11-0132-6	132	145	150	160	165	175	600	100	11A7
GD800-11-0160-6	160	165	175	185	190	200			
GD800-11-0200-6	200	210	220	220	230	240			
GD800-11-0250-6	250	255	270	285	286	300	1650	180	11A8
GD800-11-0315-6	315	334	350	350	360	380			
GD800-11-0400-6	400	411	430	450	465	480			
GD800-11-0500-6	500	518	540	550	570	585	600	120	11B7
GD800-11-0160-6-B	160	165	175	185	190	200			
GD800-11-0200-6-B	200	210	220	220	230	240			
GD800-11-0250-6-B	250	255	270	285	286	300	800	160	11B8
GD800-11-0315-6-B	315	334	350	350	360	380			
GD800-11-0400-6-B	400	411	430	450	465	480			
GD800-11-0500-6-B	500	518	540	550	570	585	1400	450	11B9

Note: Goodrive800-11 does not have standard control units, but it needs to work with the control unit. In the light load application of GD800-11-0500-6, it is necessary to reduce the environment temperature below 30 degree or the carrier frequency below 1.5k because of the heating-releasing limit when it runs continuously at full load.

Signs:

Typical capacity of heavy load application (150% overload capacity)		Typical capacity of light application (110% overload capacity)	
P_{Lh}	Typical value of available motor power	P_L	Typical value of available motor power
I_{ih}	Continuous valid input current	I_i	Continuous valid input current
I_{oh}	Continuous valid output current	I_o	Continuous valid output current
1 minute overload operation (150% overload) in every 5 minutes is available.		1 minute overload operation (110% overload) in every 5 minutes is available.	

Note: The power supply voltage will impact the continuous valid output current.

Note: The continuous valid output current and overload current is defined at 40°C. It will derate 2% for every additional 1°C if the temperature is above 40°C (the maximum temperature will not exceed 50°C).

3.4.2 Main parameters of Goodrive800-51 series power unit

Model	Heavy overload application			Light overload application			Air volume (m ³ /h)	Weight (kg)	Structure
	Q _{ih} (kVA)	P _{Ld} (kW)	I _{oh} (A)	Q _l (kVA)	P _L (kW)	I _o (A)			
U_N =380 V									
GD800-51-0037-4	50	37	75	62	45	92	250	22	51A5
GD800-51-0045-4	62	45	92	76	55	115			
GD800-51-0055-4	76	55	115	99	75	150			
GD800-51-0075-4	99	75	150	120	90	180	400	34	51A6
GD800-51-0090-4	120	90	180	142	110	215			
GD800-51-0110-4	142	110	215	172	132	260			
GD800-51-0132-4	172	132	260	200	160	305	600	80	51A7
GD800-51-0160-4	200	160	305	235	185	355			
GD800-51-0200-4	250	200	380	280	220	425			
GD800-51-0250-4	316	250	480	350	285	530	1650	150	51A8
GD800-51-0315-4	395	315	600	430	350	650			
GD800-51-0400-4	475	400	720	535	450	810			
GD800-51-0132-4-B	172	132	260	200	160	305	600	80	51B7
GD800-51-0160-4-B	200	160	305	235	185	355			
GD800-51-0200-4-B	250	200	380	280	220	425			
U_N =500 V									
GD800-51-0037-5	55	37	63	65	45	75	250	22	51A5
GD800-51-0045-5	65	45	75	80	55	92			
GD800-51-0055-5	80	55	92	105	75	120			
GD800-51-0075-5	105	75	120	130	90	150	400	34	51A6
GD800-51-0090-5	130	90	150	152	110	175			
GD800-51-0110-5	152	110	175	182	132	210			
GD800-51-0132-5	182	132	210	220	160	255	600	80	51A7
GD800-51-0160-5	220	160	255	252	185	290			
GD800-51-0200-5	282	200	325	305	220	350			
GD800-51-0250-5	342	250	395	368	285	425	1650	150	51A8
GD800-51-0315-5	442	315	510	472	350	545			
GD800-51-0400-5	538	400	620	576	450	665			
GD800-51-0132-5-B	182	132	210	220	160	255	600	80	51B7
GD800-51-0160-5-B	220	160	255	252	185	290			
GD800-51-0200-5-B	282	200	325	305	220	350			
U_N =660 V									
GD800-51-0075-6	98	75	86	112	90	98	400	34	51A6
GD800-51-0090-6	112	90	98	138	110	120			
GD800-51-0110-6	138	110	120	172	132	150			
GD800-51-0132-6	172	132	150	200	160	175			
GD800-51-0160-6	200	160	175	230	185	200	600	80	51A7

Model	Heavy overload application			Light overload application			Air volume (m ³ /h)	Weight (kg)	Structure
	Q _{Ih} (kVA)	P _{Ld} (kW)	I _{oh} (A)	Q _I (kVA)	P _L (kW)	I _o (A)			
GD800-51-0200-6	252	200	220	275	220	240	1650	150	51A8
GD800-51-0250-6	310	250	270	345	285	300			
GD800-51-0315-6	400	315	350	435	350	380			
GD800-51-0400-6	492	400	430	550	450	480	600	80	51B7
GD800-51-0500-6	620	500	540	670	550	585			
GD800-51-0160-6-B	200	160	175	230	185	200			
GD800-51-0200-6-B	252	200	220	275	220	240	600	80	51B7
GD800-51-0250-6-B	310	250	270	345	285	300			

Note: Goodrive800-51 does not have standard control units, but it needs to work with the control unit. In the light load application of GD800-51-0500-6, it is necessary to reduce the environment temperature below 30 degree or the carrier frequency below 1.5k because of the heating-releasing limit when it runs continuously at full load.

Signs:

Typical capacity of heavy load application (150% overload capacity)		Typical capacity of light application (110% overload capacity)	
Q _{Ih}	Rated input capacity	Q _I	Rated input capacity
P _{Lh}	Typical value of available motor power	P _L	Typical value of available motor power
I _{oh}	Continuous valid output current	I _o	Continuous valid output current
1 minute overload operation (150% overload) in every 5 minutes is available.		1 minute overload operation (110% overload) in every 5 minutes is available.	

Note: The power supply voltage will impact the continuous valid output current.

Note: The continuous valid output current and overload current is defined at 40°C. It will derate 2% for every additional 1°C if the temperature is above 40°C (the maximum temperature will not exceed 50°C).

3.4.3 Main parameters of Goodrive800-61 series diode rectification unit

Model	Heavy overload application		Light overload application		Air volume (m ³ /h)	Weight (kg)	Structure
	Q _{ih} (kVA)	I _{ih} (A)	Q _l (kVA)	I _l (A)			
U_N = 380 V							
GD800-61-0200-4	265	2*200	290	2*220	200	20	61A7
GD800-61-0400-4	500	2*380	565	2*430	400	30	61A8
U_N = 500 V							
GD800-61-0200-5	285	2*165	310	2*180	200	20	61A7
GD800-61-0400-5	554	2*320	606	2*350	400	30	61A8
U_N = 660 V							
GD800-61-0250-6	320	2*140	345	2*150	200	20	61A7
GD800-61-0500-6	630	2*275	688	2*300	400	30	61A8

Note: In the light load application of GD800-61-0500-6, it is necessary to reduce the environment temperature below 30 degree or the carrier frequency below 1.5k because of the heating-releasing limit when it runs continuously at full load.

Signs:

Typical capacity of heavy load application (150% overload capacity)		Typical capacity of light application (110% overload capacity)	
Q _{ih}	Rated input capacity	Q _l	Rated input capacity
I _{ih}	Continuous valid input current	I _l	Continuous valid input current
1 minute overload operation (150% overload) in every 5 minutes is available.		1 minute overload operation (110% overload) in every 5 minutes is available.	

Note: The power supply voltage will impact the continuous valid output current.

Note: The continuous valid output current and overload current is defined at 40°C. It will derate 2% for every additional 1°C if the temperature is above 40°C (the maximum temperature will not exceed 50°C).

3.4.4 Main parameters of Goodrive800-26 series four-quadrant cabinet inverter

Model	Heavy overload application			Light overload application			Weight (kg)	Structure		
	P _{Lh} (kW)	I _{ih} (A)	I _{oh} (A)	P _L (kW)	I _l (A)	I _o (A)				
U_N =380 V										
GD800-26-0075-4	75	130	150	90	156	180	400	26S1		
GD800-26-0090-4	90	156	180	110	190	215				
GD800-26-0110-4	110	190	215	132	230	260				
GD800-26-0132-4	132	230	260	160	280	305	600	26S2		
GD800-26-0160-4	160	280	305	185	320	355				
GD800-26-0200-4	200	345	380	220	385	425				
GD800-26-0250-4-MSC	250	435	480	285	495	530	1100	26S3		
GD800-26-0250-4-MLR								26M1		
GD800-26-0250-4-MRL								26S3		
GD800-26-0315-4-MSC	315	545	600	350	605	650		26M1		
GD800-26-0315-4-MLR								26S3		
GD800-26-0315-4-MRL								26M1		
GD800-26-0400-4-MSC	400	695	720	450	780	810		26S3		
GD800-26-0400-4-MLR								26M1		
GD800-26-0400-4-MRL										
GD800-26-0500-4-MLR	500	870	960	570	990	1060	1800	26M2		
GD800-26-0500-4-MRL										
GD800-26-0630-4-MLR	630	1090	1200	700	1210	1300				
GD800-26-0630-4-MRL										
GD800-26-0800-4-MLR	800	1390	1440	900	1560	1620				
GD800-26-0800-4-MRL										
GD800-26-1000-4-MLR	1000	1635	1800	1100	1815	1950			2500	26M3
GD800-26-1000-4-MRL										
GD800-26-1200-4-MLR	1200	2085	2160	1350	2340	2430				
GD800-26-1200-4-MRL										
U_N =500 V										
GD800-26-0075-5	75	105	120	90	125	150	400	26S1		
GD800-26-0090-5	90	125	150	110	150	175				
GD800-26-0110-5	110	150	175	132	182	210				
GD800-26-0132-5	132	182	210	160	220	255	600	26S2		
GD800-26-0160-5	160	220	255	185	255	290				
GD800-26-0200-5	200	275	325	220	302	350				
GD800-26-0250-5-MSC	250	345	395	285	390	425	1100	26S3		
GD800-26-0250-5-MLR								26M1		
GD800-26-0250-5-MRL										
GD800-26-0315-5-MSC	315	430	510	350	480	545		26S3		
GD800-26-0315-5-MLR								26M1		

Model	Heavy overload application			Light overload application			Weight (kg)	Structure		
	P _{Lh} (kW)	I _{lh} (A)	I _{oh} (A)	P _L (kW)	I _l (A)	I _o (A)				
GD800-26-0315-5-MRL							1800	26S3 26M1		
GD800-26-0400-5-MS	400	550	620	450	620	665				
GD800-26-0400-5-MLR										
GD800-26-0400-5-MRL										
GD800-26-0500-5-MLR	500	690	790	570	780	850	1800	26M2		
GD800-26-0500-5-MRL										
GD800-26-0630-5-MLR	630	860	1020	700	960	1090				
GD800-26-0630-5-MRL										
GD800-26-0800-5-MLR	800	1100	1240	900	1240	1330	2500	26M3		
GD800-26-0800-5-MRL										
GD800-26-1000-5-MLR	1000	1290	1530	1100	1440	1635				
GD800-26-1000-5-MRL										
GD800-26-1200-5-MLR	1200	1650	1860	1350	1860	1995				
GD800-26-1200-5-MRL										
U_N =660 V										
GD800-26-0075-6	75	75	86	90	90	98	400	26S1		
GD800-26-0090-6	90	90	98	110	110	120				
GD800-26-0110-6	110	110	120	132	132	150				
GD800-26-0132-6	132	132	150	160	160	175				
GD800-26-0160-6	160	160	175	185	185	200	600	26S2		
GD800-26-0200-6	200	200	220	220	220	240				
GD800-26-0250-6	250	250	270	285	285	300				
GD800-26-0315-6-MS	315	315	350	350	350	380	1100	26S3		
GD800-26-0315-6-MLR								26M1		
GD800-26-0315-6-MRL										
GD800-26-0400-6-MS	400	400	430	450	450	480		26S3		
GD800-26-0400-6-MLR								26M1		
GD800-26-0400-6-MRL										
GD800-26-0500-6-MS	500	500	540	570	570	585	26S3			
GD800-26-0500-6-MLR							26M1			
GD800-26-0500-6-MRL										
GD800-26-0630-6-MLR	630	630	700	700	700	760	1800	26M2		
GD800-26-0630-6-MRL										
GD800-26-0800-6-MLR	800	800	860	900	900	960				
GD800-26-0800-6-MRL										
GD800-26-1000-6-MLR	1000	1000	1080	1100	1100	1170			2500	26M3
GD800-26-1000-6-MRL										
GD800-26-1200-6-MLR	1200	1200	1290	1350	1350	1440				
GD800-26-1200-6-MRL										
GD800-26-1500-6-MLR	1500	1500	1620	1650	1650	1755				

Model	Heavy overload application			Light overload application			Weight (kg)	Structure
	P _{Lh} (kW)	I _{ih} (A)	I _{oh} (A)	P _L (kW)	I _i (A)	I _o (A)		
GD800-26-1500-6-MRL								

Note: In the light load application of GD800-26-0500-6, GD800-26-1000-6 and GD800-26-1500-6, it is necessary to reduce the environment temperature below 30 degree or the carrier frequency below 1.5k because of the heating-releasing limit when it runs continuously at full load.

Signs:

Typical capacity of heavy load application (150% overload capacity)		Typical capacity of light application (110% overload capacity)	
P _{Lh}	Typical value of available motor power	P _L	Typical value of available motor power
I _{ih}	Continuous valid input current	I _i	Continuous valid input current
I _{oh}	Continuous valid output current	I _o	Continuous valid output current
1 minute overload operation (150% overload) in every 5 minutes is available.		1 minute overload operation (110% overload) in every 5 minutes is available.	

Note: The power supply voltage will impact the continuous valid output current.

Note: The continuous valid output current and overload current is defined at 40°C. It will derate 2% for every additional 1°C if the temperature is above 40°C (the maximum temperature will not exceed 50°C).

3.4.5 Main parameters of Goodrive800-56 series cabinet inverter

Model	Heavy overload application		Light overload application		Weight (kg)	Structure
	P _{Lh} (kW)	I _{oh} (A)	P _L (kW)	I _o (A)		
U_N =380 V						
GD800-56-0132-4	132	260	160	305	150	56S1
GD800-56-0160-4	160	305	185	355		
GD800-56-0200-4	200	380	220	525		
GD800-56-0250-4	250	480	285	530	200	
GD800-56-0315-4	315	600	350	650		
GD800-56-0400-4	400	720	450	810		
GD800-56-0500-4	500	960	570	1060	375	56S2
GD800-56-0630-4	630	1200	700	1300		
GD800-56-0800-4	800	1440	900	1620		
GD800-56-1000-4	1000	1800	1100	1950	575	56M1
GD800-56-1200-4	1200	2160	1350	2430		
Remark:						
1. Contact the company for the inverters below 380V-132kW of Goodrive800-56 series.						
2. Parallel operation is available for the inverters above 380V-1200kW of Goodrive800-56 series. For example, two GD800-56-1000-4 inverters can be parallel-connected to use as one GD800-56-2000-4 inverter.						
U_N =500 V						
GD800-56-0132-5	132	210	160	255	150	56S1
GD800-56-0160-5	160	255	185	290		
GD800-56-0200-5	200	325	220	350		
GD800-56-0250-5	250	395	285	425	200	
GD800-56-0315-5	315	510	350	545		
GD800-56-0400-5	400	620	450	665		
GD800-56-0500-5	500	790	570	850	375	56S2
GD800-56-0630-5	630	1020	700	1090		
GD800-56-0800-5	800	1240	900	1330		
GD800-56-1000-5	1000	1530	1100	1635	575	56M1
GD800-56-1200-5	1200	1860	1350	1995		
Remark:						
1. Contact the company for the inverters below 500V-132kW of Goodrive800-56 series.						
2. Parallel operation is available for the inverters above 500V-1200kW of Goodrive800-56 series. For example, two GD800-56-1000-5 inverters can be parallel-connected to use as one GD800-56-2000-5 inverter.						
U_N =660 V						
GD800-56-0160-6	160	175	185	200	150	56S1
GD800-56-0200-6	200	220	220	240		
GD800-56-0250-6	250	270	285	300		
GD800-56-0315-6	315	350	350	380	200	

Model	Heavy overload application		Light overload application		Weight (kg)	Structure
	P_{Lh} (kW)	I_{oh} (A)	P_L (kW)	I_o (A)		
GD800-56-0400-6	400	430	450	480	375	56S2
GD800-56-0500-6	500	540	570	585		
GD800-56-0630-6	630	700	700	760		
GD800-56-0800-6	800	860	900	960		
GD800-56-1000-6	1000	1080	1100	1170	575	56M1
GD800-56-1200-6	1200	1290	1350	1440		
GD800-56-1500-6	1500	1620	1650	1755		

Remark:

1. Contact the company for the inverters below 660V-160kW of Goodrive800-56 series.
2. Parallel operation is available for the inverters above 660V-1500kW of Goodrive800-56 series. For example, two GD800-56-1000-6 inverters can be parallel-connected to use as one GD800-56-2000-6 inverter.

Note: In the light load application of GD800-56-0500-6, GD800-56-1000-6 and GD800-56-1500-6, it is necessary to reduce the environment temperature below 30 degree or the carrier frequency below 1.5k because of the heating-releasing limit when it runs continuously at full load.

Signs:

Typical capacity of heavy load application (150% overload capacity)		Typical capacity of light application (110% overload capacity)	
P_{Lh}	Typical value of available motor power	P_L	Typical value of available motor power
I_{oh}	Continuous valid output current	I_o	Continuous valid output current
1 minute overload operation (150% overload) in every 5 minutes is available.		1 minute overload operation (110% overload) in every 5 minutes is available.	

Note: The power supply voltage will impact the continuous valid output current.

Note: The continuous valid output current and overload current is defined at 40°C. It will derate 2% for every additional 1°C if the temperature is above 40°C (the maximum temperature will not exceed 50°C).

3.4.6 Main parameters of Goodrive800-96 series cabinet IGBT PWM rectifier

Model	Heavy overload application		Light overload application		Weight (kg)	Structure
	Q _{ih} (kVA)	I _{ih} (A)	Q _l (kVA)	I _l (A)		
U_N = 380 V						
GD800-96-0075-4	86	130	103	156	360	26S1
GD800-96-0090-4	103	156	125	190		
GD800-96-0110-4	125	190	152	230		
GD800-96-0132-4	152	230	185	280	520	26S2
GD800-96-0160-4	185	280	212	320		
GD800-96-0200-4	230	345	255	385		
GD800-96-0250-4-MLR	286	435	326	495	950	96M1
GD800-96-0250-4-MRL						
GD800-96-0315-4-MLR	360	545	400	605		
GD800-96-0315-4-MRL						
GD800-96-0400-4-MLR	458	695	515	780		
GD800-96-0400-4-MRL						
GD800-96-0500-4-MLR	572	870	652	990	1450	96M2
GD800-96-0500-4-MRL						
GD800-96-0630-4-MLR	720	1090	800	1210		
GD800-96-0630-4-MRL						
GD800-96-0800-4-MLR	916	1390	1030	1560		
GD800-96-0800-4-MRL						
GD800-96-1000-4-MLR	1080	1635	1200	1815	1950	96M3
GD800-96-1000-4-MRL						
GD800-96-1200-4-MLR	1374	2085	1545	2340		
GD800-96-1200-4-MRL						
Remark:						
Parallel operation is available for the inverters above 380V-1200kW of Goodrive800-96 series. For example, two GD800-96-1000-4 inverters can be parallel-connected to use as one GD800-96-2000-4 inverter.						
U_N = 500 V						
GD800-96-0075-5	92	105	110	125	360	26S1
GD800-96-0090-5	110	125	130	150		
GD800-96-0110-5	130	150	158	182		
GD800-96-0132-5	158	182	190	220	520	26S2
GD800-96-0160-5	190	220	220	255		
GD800-96-0200-5	240	275	262	302		
GD800-96-0250-5-MLR	300	345	340	390	950	96M1
GD800-96-0250-5-MRL						

Model	Heavy overload application		Light overload application		Weight (kg)	Structure
	Q _{ih} (kVA)	I _{ih} (A)	Q _l (kVA)	I _l (A)		
GD800-96-0315-5-MLR	375	430	416	480	1450	96M2
GD800-96-0315-5-MRL						
GD800-96-0400-5-MLR	480	550	538	620		
GD800-96-0400-5-MRL						
GD800-96-0500-5-MLR	600	690	680	780		
GD800-96-0500-5-MRL						
GD800-96-0630-5-MLR	750	860	832	960		
GD800-96-0630-5-MRL						
GD800-96-0800-5-MLR	960	1100	1076	1240		
GD800-96-0800-5-MRL						
GD800-96-1000-5-MLR	1125	1290	1248	1440	1950	96M3
GD800-96-1000-5-MRL						
GD800-96-1200-5-MLR	1440	1650	1614	1860		
GD800-96-1200-5-MRL						
Remark:						
Parallel operation is available for the inverters above 500V-1200kW of Goodrive800-96 series. For example, two GD800-96-1000-5 inverters can be parallel-connected to use as one GD800-96-2000-5 inverter.						
U_N = 660 V						
GD800-96-0075-6	86	75	103	90	360	26S1
GD800-96-0090-6	103	90	125	110		
GD800-96-0110-6	125	110	152	132		
GD800-96-0132-6	152	132	185	160		
GD800-96-0160-6	185	160	212	185	520	26S2
GD800-96-0200-6	230	200	255	220		
GD800-96-0250-6	286	250	326	285		
GD800-96-0315-6-MLR	360	315	400	350	950	96M1
GD800-96-0315-6-MRL						
GD800-96-0400-6-MLR	458	400	515	450		
GD800-96-0400-6-MRL						
GD800-96-0500-6-MLR	572	500	630	550		
GD800-96-0500-6-MRL						
GD800-96-0630-6-MLR	720	630	800	700		
GD800-96-0630-6-MRL						
GD800-96-0800-6-MLR	916	800	1030	900	1450	96M2
GD800-96-0800-6-MRL						
GD800-96-1000-6-MLR	1144	1000	1260	1100		
GD800-96-1000-6-MRL						

Model	Heavy overload application		Light overload application		Weight (kg)	Structure
	Q_{ih} (kVA)	I_{ih} (A)	Q_l (kVA)	I_l (A)		
GD800-96-1200-6-MLR	1374	1200	1545	1350	1950	96M3
GD800-96-1200-6-MRL						
GD800-96-1500-6-MLR	1716	1500	1890	1650		
GD800-96-1500-6-MRL						

Remark:

Parallel operation is available for the inverters above 660V-1500kW of Goodrive800-96 series. For example, two GD800-96-1000-6 inverters can be parallel-connected to use as one GD800-96-2000-6 inverter.

Note: In the light load application of GD800-96-0500-6, GD800-96-1000-6 and GD800-96-1500-6, it is necessary to reduce the environment temperature below 30 degree or the carrier frequency below 1.5k because of the heating-releasing limit when it runs continuously at full load.

Signs:

Typical capacity of heavy load application (150% overload capacity)		Typical capacity of light application (110% overload capacity)	
Q_{ih}	Rated input capacity	Q_l	Rated input capacity
I_{ih}	Continuous valid input current	I_l	Continuous valid input current
1 minute overload operation (150% overload) in every 5 minutes is available.		1 minute overload operation (110% overload) in every 5 minutes is available.	

Note: The power supply voltage will impact the continuous valid output current.

Note: The continuous valid output current and overload current is defined at 40°C. It will derate 2% for every additional 1°C if the temperature is above 40°C (the maximum temperature will not exceed 50°C).

3.4.7 Main parameters of Goodrive800-01 LCL PWM filter unit

Model	Q_h (kVA)	I_h (A)	Air volume(m^3/h)	Weight (kg)	Structure
$U_N = 380 V$					
GD800-01-0250-4	326	495	680	200	01A8
GD800-01-0315-4	400	605			
GD800-01-0400-4	515	780			
$U_N = 500 V$					
GD800-01-0250-5	340	390	680	200	01A8
GD800-01-0315-5	416	430			
GD800-01-0400-5	538	620			
$U_N = 660 V$					
GD800-01-0315-6	480	350	680	200	01A8
GD800-01-0400-6	515	450			
GD800-01-0500-6	630	550			

Note: Be used with PWM rectification unit with same voltage, same power and same capacity.

Note: In the light load application of GD800-01-0500-6, it is necessary to reduce the environment temperature below 30 degree or the carrier frequency below 1.5k because of the heating-releasing limit when it runs continuously at full load.

3.4.8 Main parameters of Goodrive800-02 series sine wave filter unit

Model	I _h (A)	Air volume(m ³ /h)	Weight (kg)	Structure
U_N =380 V				
GD800-02-0250-4	480	680	200	02A8
GD800-02-0315-4	600			
GD800-02-0400-4	720			
U_N =500 V				
GD800-02-0250-5	395	680	200	02A8
GD800-02-0315-5	510			
GD800-02-0400-5	620			
U_N =660 V				
GD800-02-0315-6	350	680	200	02A8
GD800-02-0400-6	430			
GD800-02-0500-6	540			

Note: In the light load application of GD800-02-0500-6, it is necessary to reduce the environment temperature below 30 degree or the carrier frequency below 1.5k because of the heating-releasing limit when it runs continuously at full load.

3.4.9 Main parameters of Goodrive800-03 series bus capacitor energy storage / filter unit

Model	C(mF)	I _i (A)	Air volume(m ³ /h)	Weight (kg)	Structure
U_N =380 V					
GD800-03-0800-4	61.8	700	680	200	03A8
GD800-03-1000-4	75	820			
GD800-03-1200-4	90.5	960			
U_N =500 V					
GD800-03-0800-5	Reserved	Reserved	Reserved	Reserved	Reserved
GD800-03-1000-5	Reserved	Reserved			
GD800-03-1200-5	Reserved	Reserved			
U_N =660 V					
GD800-03-1000-6	27.5	468	680	200	03A8
GD800-03-1200-6	33.4	560			
GD800-03-1500-6	40.2	640			

Note: The bus capacitor energy storage / filter unit of 500V is reserved.

3.4.10 Model of Goodrive800 series control unit

3.4.10.1 Model of 380V control units

Power code	380V rectification control unit	380V variable frequency control unit
0004	/	GD800-ICU-0004-4
05R5	/	GD800-ICU-05R5-4
07R5	/	GD800-ICU-07R5-4
0011	/	GD800-ICU-0011-4
0015	/	GD800-ICU-0015-4
0018	/	GD800-ICU-0018-4
0022	/	GD800-ICU-0022-4
0030	/	GD800-ICU-0030-4
0030	/	GD800-ICU-0037-4
0045	/	GD800-ICU-0045-4
0055	/	GD800-ICU-0055-4
0075	GD800-RCU-0075-4	GD800-ICU-0075-4
0090	GD800-RCU-0090-4	GD800-ICU-0090-4
0110	GD800-RCU-0110-4	GD800-ICU-0110-4
0132	GD800-RCU-0132-4	GD800-ICU-0132-4
0160	GD800-RCU-0160-4	GD800-ICU-0160-4
0200	GD800-RCU-0200-4	GD800-ICU-0200-4
0250	GD800-RCU-0250-4	GD800-ICU-0250-4
0315	GD800-RCU-0315-4	GD800-ICU-0315-4
0400	GD800-RCU-0400-4	GD800-ICU-0400-4
0500	GD800-RCU-0500-4	GD800-ICU-0500-4
0630	GD800-RCU-0630-4	GD800-ICU-0630-4
0800	GD800-RCU-0800-4	GD800-ICU-0800-4
1000	GD800-RCU-1000-4	GD800-ICU-1000-4
1200	GD800-RCU-1200-4	GD800-ICU-1200-4
1500	GD800-RCU-1500-4	GD800-ICU-1500-4
1600	GD800-RCU-1600-4	GD800-ICU-1600-4
2000	GD800-RCU-2000-4	GD800-ICU-2000-4
2400	GD800-RCU-2400-4	GD800-ICU-2400-4
2500	/	/
3000	/	/

4 sets of Goodrive800 series products (380V-2400kW) can be parallel-connected through master-slave control.

The master-slave function is optional. Please note when ordering.

3.4.10.2 Model of 500V control units

Power code	500V rectification control unit	500V variable frequency control unit
0004	/	GD800-ICU-0004-5
05R5	/	GD800-ICU-05R5-5
07R5	/	GD800-ICU-07R5-5
0011	/	GD800-ICU-0011-5
0015	/	GD800-ICU-0015-5
0018	/	GD800-ICU-0018-5
0022	/	GD800-ICU-0022-5
0030	/	GD800-ICU-0030-5
0030	/	GD800-ICU-0037-5
0045	/	GD800-ICU-0045-5
0055	/	GD800-ICU-0055-5
0075	GD800-RCU-0075-5	GD800-ICU-0075-5
0090	GD800-RCU-0090-5	GD800-ICU-0090-5
0110	GD800-RCU-0110-5	GD800-ICU-0110-5
0132	GD800-RCU-0132-5	GD800-ICU-0132-5
0160	GD800-RCU-0160-5	GD800-ICU-0160-5
0200	GD800-RCU-0200-5	GD800-ICU-0200-5
0250	GD800-RCU-0250-5	GD800-ICU-0250-5
0315	GD800-RCU-0315-5	GD800-ICU-0315-5
0400	GD800-RCU-0400-5	GD800-ICU-0400-5
0500	GD800-RCU-0500-5	GD800-ICU-0500-5
0630	GD800-RCU-0630-5	GD800-ICU-0630-5
0800	GD800-RCU-0800-5	GD800-ICU-0800-5
1000	GD800-RCU-1000-5	GD800-ICU-1000-5
1200	GD800-RCU-1200-5	GD800-ICU-1200-5
1500	GD800-RCU-1500-5	GD800-ICU-1500-5
1600	GD800-RCU-1600-5	GD800-ICU-1600-5
2000	GD800-RCU-2000-5	GD800-ICU-2000-5
2400	GD800-RCU-2400-5	GD800-ICU-2400-5
2500	/	/
3000	/	/

4 sets of Goodrive800 series products (500V-2400kW) can be parallel-connected through master-slave control.

The master-slave function is optional. Please note when ordering.

3.4.10.3 Model of 660V control units

Power code	660V rectification control unit	660V variable frequency control unit
0004	/	/
05R5	/	/
07R5	/	/
0011	/	/
0015	/	/
0018	/	/
0022	/	GD800-ICU-0022-6
0030	/	GD800-ICU-0030-6
0030	/	GD800-ICU-0037-6
0045	/	GD800-ICU-0045-6
0055	/	GD800-ICU-0055-6
0075	GD800-RCU-0075-6	GD800-ICU-0075-6
0090	GD800-RCU-0090-6	GD800-ICU-0090-6
0110	GD800-RCU-0110-6	GD800-ICU-0110-6
0132	GD800-RCU-0132-6	GD800-ICU-0132-6
0160	GD800-RCU-0160-6	GD800-ICU-0160-6
0200	GD800-RCU-0200-6	GD800-ICU-0200-6
0250	GD800-RCU-0250-6	GD800-ICU-0250-6
0315	GD800-RCU-0315-6	GD800-ICU-0315-6
0400	GD800-RCU-0400-6	GD800-ICU-0400-6
0500	GD800-RCU-0500-6	GD800-ICU-0500-6
0630	GD800-RCU-0630-6	GD800-ICU-0630-6
0800	GD800-RCU-0800-6	GD800-ICU-0800-6
1000	GD800-RCU-1000-6	GD800-ICU-1000-6
1200	GD800-RCU-1200-6	GD800-ICU-1200-6
1500	GD800-RCU-1500-6	GD800-ICU-1500-6
1600	GD800-RCU-1600-6	GD800-ICU-1600-6
2000	GD800-RCU-2000-6	GD800-ICU-2000-6
2400	GD800-RCU-2400-6	GD800-ICU-2400-6
2500	GD800-RCU-2500-6	GD800-ICU-2500-6
3000	GD800-RCU-3000-6	GD800-ICU-3000-6

4 sets of Goodrive800 series products (660V-3000kW) can be parallel-connected through master-slave control.

The master-slave function is optional. Please note when ordering.

3.5 Loss calculation of inverters

1. Total loss of the inverter = (Bridge rectifier loss + Conduction loss of the converter bridge + Switching losses of the converter bridge)* Inverter power.

2. Current coefficient: for the rectifier bridge, it corresponds to the rated input current of the inverter; for the converter bridge, it corresponds to the rated output current of the inverter.

3. The percentage in the table below corresponds to the rated power of the inverter.

4. The total loss of the inverter is ±10% of the actual loss.

5. 1k, 2k, 3k of the switching losses of the converter bridge is the carrier frequency of the converter bridge and the carrier loss which is not in the table can be calculated by linear interpolation.

For example, if the inverter is 380V, 400kW, the current coefficient is 1 and the switching losses of the converter are 2k:

$$\text{Total loss of the inverter} = (0.47\% + 0.72\% + 0.34\%) * 400000 = 6120(\text{W}) = 6.12(\text{kW})$$

Voltage degree	Current coefficient	Bridge rectifier loss	Conduction loss of the converter bridge	Switching losses of the converter bridge							
				1k	2k	3k	4k	5k	6k	7k	8k
380V	0.5	0.18%	0.29%	0.08%	0.17%	0.25%	0.34%	0.42%	0.51%	0.59%	0.68%
	0.55	0.20%	0.32%	0.09%	0.19%	0.28%	0.37%	0.47%	0.56%	0.65%	0.75%
	0.6	0.22%	0.36%	0.10%	0.20%	0.31%	0.41%	0.51%	0.61%	0.71%	0.81%
	0.65	0.25%	0.40%	0.11%	0.22%	0.33%	0.44%	0.55%	0.66%	0.77%	0.88%
	0.7	0.28%	0.44%	0.12%	0.24%	0.36%	0.47%	0.59%	0.71%	0.83%	0.95%
	0.75	0.31%	0.48%	0.13%	0.25%	0.38%	0.51%	0.64%	0.76%	0.89%	1.02%
	0.8	0.34%	0.53%	0.14%	0.27%	0.41%	0.54%	0.68%	0.81%	0.95%	1.09%
	0.85	0.37%	0.57%	0.14%	0.29%	0.43%	0.58%	0.72%	0.86%	1.01%	1.15%
	0.9	0.40%	0.62%	0.15%	0.31%	0.46%	0.61%	0.76%	0.92%	1.07%	1.22%
	0.95	0.43%	0.67%	0.16%	0.32%	0.48%	0.64%	0.81%	0.97%	1.13%	1.29%
	1	0.47%	0.72%	0.17%	0.34%	0.51%	0.68%	0.85%	1.02%	1.19%	1.36%
	1.05	0.51%	0.77%	0.18%	0.36%	0.53%	0.71%	0.89%	1.07%	1.25%	1.42%
	1.1	0.54%	0.82%	0.19%	0.37%	0.56%	0.75%	0.93%	1.12%	1.31%	1.49%
	1.15	0.58%	0.87%	0.19%	0.39%	0.58%	0.78%	0.97%	1.17%	1.36%	1.56%
	1.2	0.62%	0.93%	0.20%	0.41%	0.61%	0.81%	1.02%	1.22%	1.42%	1.63%
	1.25	0.66%	0.99%	0.21%	0.42%	0.64%	0.85%	1.06%	1.27%	1.48%	1.70%
	1.3	0.70%	1.04%	0.22%	0.44%	0.66%	0.88%	1.10%	1.32%	1.54%	1.76%
	1.35	0.75%	1.10%	0.23%	0.46%	0.69%	0.92%	1.14%	1.37%	1.60%	1.83%
	1.4	0.79%	1.16%	0.24%	0.47%	0.71%	0.95%	1.19%	1.42%	1.66%	1.90%
	1.45	0.84%	1.23%	0.25%	0.49%	0.74%	0.98%	1.23%	1.48%	1.72%	1.97%
1.5	0.88%	1.29%	0.25%	0.51%	0.76%	1.02%	1.27%	1.53%	1.78%	2.03%	
1.55	0.93%	1.35%	0.26%	0.53%	0.79%	1.05%	1.31%	1.58%	1.84%	2.10%	
1.6	0.98%	1.42%	0.27%	0.54%	0.81%	1.09%	1.36%	1.63%	1.90%	2.17%	
1.65	1.03%	1.49%	0.28%	0.56%	0.84%	1.12%	1.40%	1.68%	1.96%	2.24%	
1.7	1.08%	1.56%	0.29%	0.58%	0.86%	1.15%	1.44%	1.73%	2.02%	2.31%	
1.75	1.13%	1.63%	0.30%	0.59%	0.89%	1.19%	1.48%	1.78%	2.08%	2.37%	
1.8	1.19%	1.70%	0.31%	0.61%	0.92%	1.22%	1.53%	1.83%	2.14%	2.44%	
1.85	1.24%	1.78%	0.31%	0.63%	0.94%	1.25%	1.57%	1.88%	2.20%	2.51%	

Voltage degree	Current coefficient	Bridge rectifier loss	Conduction loss of the converter bridge	Switching losses of the converter bridge							
				1k	2k	3k	4k	5k	6k	7k	8k
	1.9	1.30%	1.85%	0.32%	0.64%	0.97%	1.29%	1.61%	1.93%	2.26%	2.58%
	1.95	1.36%	1.93%	0.33%	0.66%	0.99%	1.32%	1.65%	1.98%	2.31%	2.65%
	2	1.41%	2.01%	0.34%	0.68%	1.02%	1.36%	1.70%	2.03%	2.37%	2.71%
500V	0.5	0.15%	0.28%	0.14%	0.29%	0.43%	0.58%	0.72%	0.87%	1.01%	1.16%
	0.55	0.17%	0.31%	0.16%	0.32%	0.48%	0.64%	0.80%	0.96%	1.11%	1.27%
	0.6	0.19%	0.35%	0.17%	0.35%	0.52%	0.69%	0.87%	1.04%	1.22%	1.39%
	0.65	0.21%	0.39%	0.19%	0.38%	0.56%	0.75%	0.94%	1.13%	1.32%	1.51%
	0.7	0.23%	0.42%	0.20%	0.41%	0.61%	0.81%	1.01%	1.22%	1.42%	1.62%
	0.75	0.25%	0.46%	0.22%	0.43%	0.65%	0.87%	1.09%	1.30%	1.52%	1.74%
	0.8	0.27%	0.50%	0.23%	0.46%	0.69%	0.93%	1.16%	1.39%	1.62%	1.85%
	0.85	0.29%	0.55%	0.25%	0.49%	0.74%	0.98%	1.23%	1.48%	1.72%	1.97%
	0.9	0.31%	0.59%	0.26%	0.52%	0.78%	1.04%	1.30%	1.56%	1.82%	2.08%
	0.95	0.34%	0.64%	0.28%	0.55%	0.83%	1.10%	1.38%	1.65%	1.93%	2.20%
	1	0.36%	0.68%	0.29%	0.58%	0.87%	1.16%	1.45%	1.74%	2.03%	2.32%
	1.05	0.38%	0.73%	0.30%	0.61%	0.91%	1.22%	1.52%	1.82%	2.13%	2.43%
	1.1	0.41%	0.78%	0.32%	0.64%	0.96%	1.27%	1.59%	1.91%	2.23%	2.55%
	1.15	0.43%	0.83%	0.33%	0.67%	1.00%	1.33%	1.67%	2.00%	2.33%	2.66%
	1.2	0.46%	0.88%	0.35%	0.69%	1.04%	1.39%	1.74%	2.08%	2.43%	2.78%
	1.25	0.48%	0.93%	0.36%	0.72%	1.09%	1.45%	1.81%	2.17%	2.53%	2.90%
	1.3	0.51%	0.99%	0.38%	0.75%	1.13%	1.51%	1.88%	2.26%	2.64%	3.01%
	1.35	0.53%	1.04%	0.39%	0.78%	1.17%	1.56%	1.95%	2.35%	2.74%	3.13%
	1.4	0.56%	1.10%	0.41%	0.81%	1.22%	1.62%	2.03%	2.43%	2.84%	3.24%
	1.45	0.59%	1.15%	0.42%	0.84%	1.26%	1.68%	2.10%	2.52%	2.94%	3.36%
	1.5	0.62%	1.21%	0.43%	0.87%	1.30%	1.74%	2.17%	2.61%	3.04%	3.47%
1.55	0.65%	1.27%	0.45%	0.90%	1.35%	1.80%	2.24%	2.69%	3.14%	3.59%	
1.6	0.68%	1.33%	0.46%	0.93%	1.39%	1.85%	2.32%	2.78%	3.24%	3.71%	
1.65	0.71%	1.40%	0.48%	0.96%	1.43%	1.91%	2.39%	2.87%	3.34%	3.82%	
1.7	0.74%	1.46%	0.49%	0.98%	1.48%	1.97%	2.46%	2.95%	3.45%	3.94%	
1.75	0.77%	1.53%	0.51%	1.01%	1.52%	2.03%	2.53%	3.04%	3.55%	4.05%	
1.8	0.80%	1.59%	0.52%	1.04%	1.56%	2.08%	2.61%	3.13%	3.65%	4.17%	
1.85	0.83%	1.66%	0.54%	1.07%	1.61%	2.14%	2.68%	3.21%	3.75%	4.29%	
1.9	0.86%	1.73%	0.55%	1.10%	1.65%	2.20%	2.75%	3.30%	3.85%	4.40%	
1.95	0.90%	1.80%	0.56%	1.13%	1.69%	2.26%	2.82%	3.39%	3.95%	4.52%	
2	0.93%	1.87%	0.58%	1.16%	1.74%	2.32%	2.90%	3.47%	4.05%	4.63%	
660V	0.5	0.11%	0.18%	0.14%	0.29%	0.43%	0.57%	0.71%	0.86%	1.00%	1.14%
	0.55	0.12%	0.21%	0.16%	0.31%	0.47%	0.63%	0.79%	0.94%	1.10%	1.26%
	0.6	0.13%	0.23%	0.17%	0.34%	0.51%	0.69%	0.86%	1.03%	1.20%	1.37%
	0.65	0.15%	0.26%	0.19%	0.37%	0.56%	0.74%	0.93%	1.11%	1.30%	1.49%
	0.7	0.16%	0.28%	0.20%	0.40%	0.60%	0.80%	1.00%	1.20%	1.40%	1.60%
	0.75	0.17%	0.31%	0.21%	0.43%	0.64%	0.86%	1.07%	1.29%	1.50%	1.71%
	0.8	0.19%	0.34%	0.23%	0.46%	0.69%	0.91%	1.14%	1.37%	1.60%	1.83%

Voltage degree	Current coefficient	Bridge rectifier loss	Conduction loss of the converter bridge	Switching losses of the converter bridge							
				1k	2k	3k	4k	5k	6k	7k	8k
0.85	0.20%	0.37%	0.24%	0.49%	0.73%	0.97%	1.21%	1.46%	1.70%	1.94%	
0.9	0.21%	0.39%	0.26%	0.51%	0.77%	1.03%	1.29%	1.54%	1.80%	2.06%	
0.95	0.23%	0.42%	0.27%	0.54%	0.81%	1.09%	1.36%	1.63%	1.90%	2.17%	
1	0.24%	0.46%	0.29%	0.57%	0.86%	1.14%	1.43%	1.71%	2.00%	2.29%	
1.05	0.26%	0.49%	0.30%	0.60%	0.90%	1.20%	1.50%	1.80%	2.10%	2.40%	
1.1	0.28%	0.52%	0.31%	0.63%	0.94%	1.26%	1.57%	1.89%	2.20%	2.51%	
1.15	0.29%	0.55%	0.33%	0.66%	0.99%	1.31%	1.64%	1.97%	2.30%	2.63%	
1.2	0.31%	0.59%	0.34%	0.69%	1.03%	1.37%	1.71%	2.06%	2.40%	2.74%	
1.25	0.33%	0.62%	0.36%	0.71%	1.07%	1.43%	1.79%	2.14%	2.50%	2.86%	
1.3	0.34%	0.66%	0.37%	0.74%	1.11%	1.49%	1.86%	2.23%	2.60%	2.97%	
1.35	0.36%	0.70%	0.39%	0.77%	1.16%	1.54%	1.93%	2.31%	2.70%	3.09%	
1.4	0.38%	0.73%	0.40%	0.80%	1.20%	1.60%	2.00%	2.40%	2.80%	3.20%	
1.45	0.40%	0.77%	0.41%	0.83%	1.24%	1.66%	2.07%	2.49%	2.90%	3.31%	
1.5	0.41%	0.81%	0.43%	0.86%	1.29%	1.71%	2.14%	2.57%	3.00%	3.43%	
1.55	0.43%	0.85%	0.44%	0.89%	1.33%	1.77%	2.21%	2.66%	3.10%	3.54%	
1.6	0.45%	0.90%	0.46%	0.91%	1.37%	1.83%	2.29%	2.74%	3.20%	3.66%	
1.65	0.47%	0.94%	0.47%	0.94%	1.41%	1.89%	2.36%	2.83%	3.30%	3.77%	
1.7	0.49%	0.98%	0.49%	0.97%	1.46%	1.94%	2.43%	2.91%	3.40%	3.89%	
1.75	0.51%	1.02%	0.50%	1.00%	1.50%	2.00%	2.50%	3.00%	3.50%	4.00%	
1.8	0.53%	1.07%	0.51%	1.03%	1.54%	2.06%	2.57%	3.09%	3.60%	4.11%	
1.85	0.55%	1.12%	0.53%	1.06%	1.59%	2.11%	2.64%	3.17%	3.70%	4.23%	
1.9	0.57%	1.16%	0.54%	1.09%	1.63%	2.17%	2.71%	3.26%	3.80%	4.34%	
1.95	0.59%	1.21%	0.56%	1.11%	1.67%	2.23%	2.79%	3.34%	3.90%	4.46%	
2	0.61%	1.26%	0.57%	1.14%	1.71%	2.29%	2.86%	3.43%	4.00%	4.57%	

Chapter 4 Electrical connection

4.1 Wiring diagram of Goodrive800-26, Goodrive800-96 and Goodrive800-56 series products

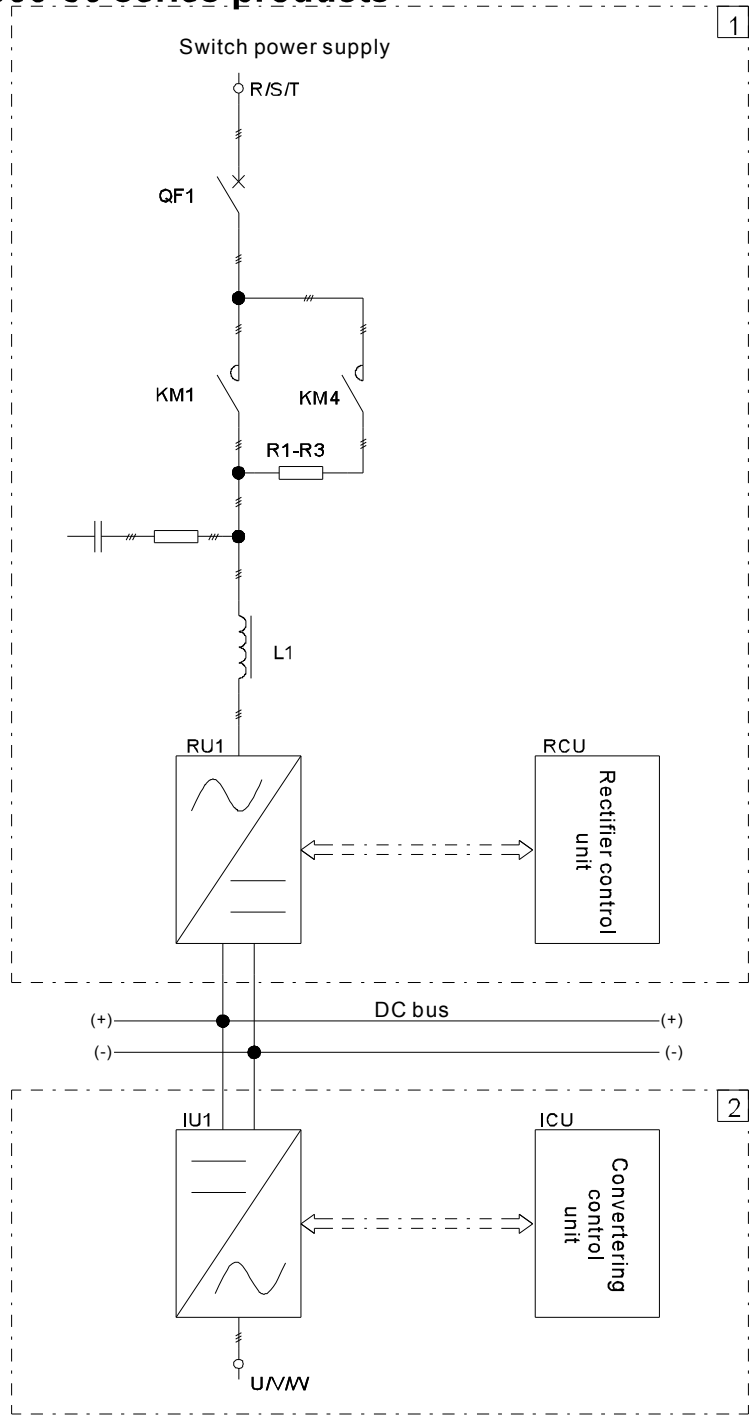

Electrical schematic diagram of the main circuit for Goodrive800-26 series 0075~0200-4, 0075~0200-5 and 0075~0250-6 is part 1 and 2 in the diagram.

Electrical schematic diagram of the main circuit for Goodrive800-96 series 0075~0200-4, 0075~0200-5 and 0075~0250-6 is part 1 in the diagram.

Electrical schematic diagram of the main circuit for Goodrive800-56 series 0132~0200-4, 0132~0200-5 and 0160~0250-6 is part 2 in the diagram.

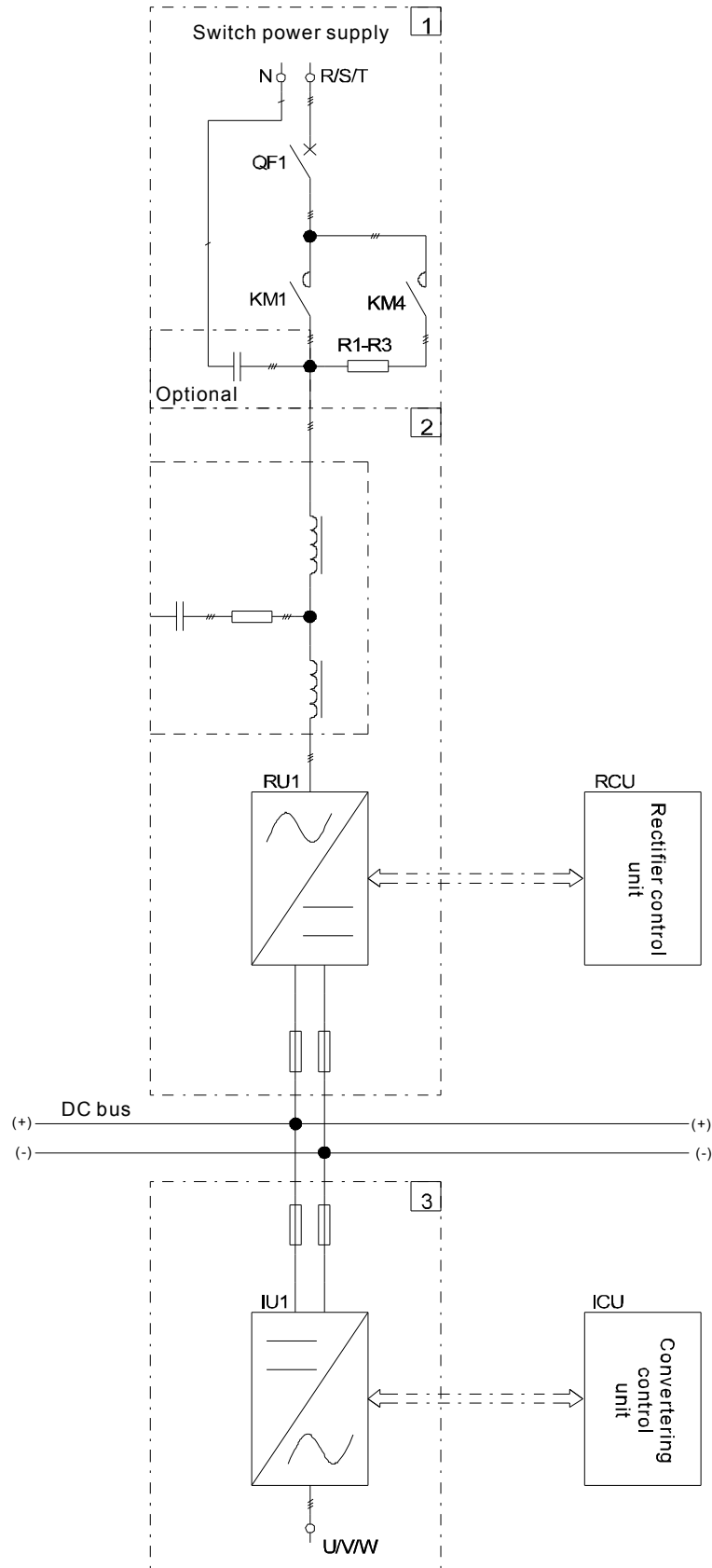

Electrical schematic diagram of the main circuit for Goodrive800-26 series 0250~0400-4, 0250~0400-5 and 0315~0500-6 is part 1, 2 and 3 in the diagram.

Electrical schematic diagram of the main circuit for Goodrive800-96 series 0250~0400-4, 0250~0400-5 and 0315~0500-6 is part 1 and 2 in the diagram.

Electrical schematic diagram of the main circuit for Goodrive800-56 series 0250~0400-4, 0250~0400-5 and 0315~0500-6 is part 3 in the diagram.

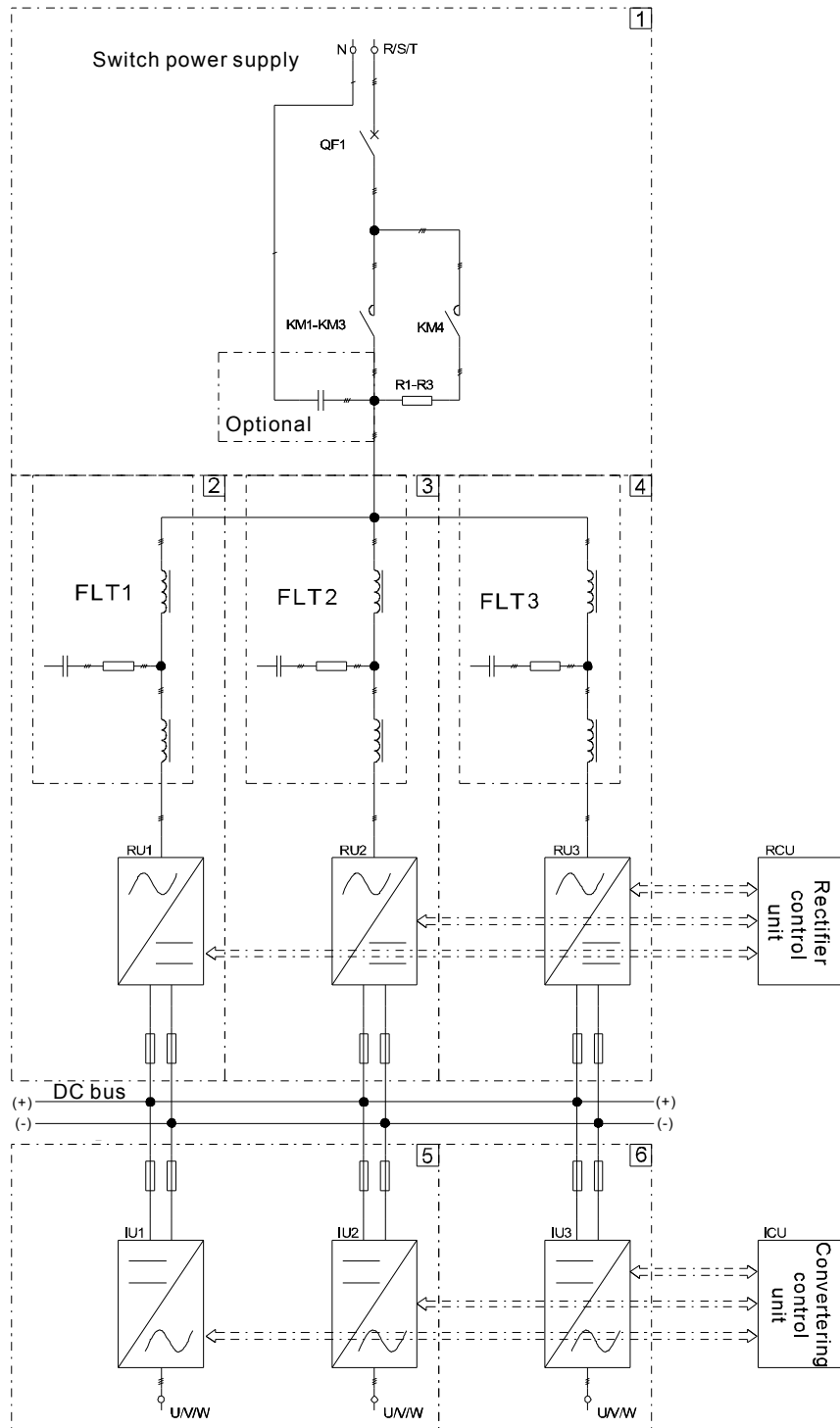

Electrical schematic diagram of the main circuit for Goodrive800-26 series 0500~0800-4, 0500~0800-5 and 0630~1000-6 is part 1, 2, 3 and 5 in the diagram.

Electrical schematic diagram of the main circuit for Goodrive800-26 series 1000~1200-4, 1000~1200-5, 1200~1500-6 is part 1, 2, 3, 4, 5 and 6 in the diagram.

Electrical schematic diagram of the main circuit for Goodrive800-96 series 0500~0800-4, 0500~0800-5 and 0630~1000-6 is part 1, 2 and 3 in the diagram.

Electrical schematic diagram of the main circuit for Goodrive800-96 series 1000~1200-4, 1000~1200-5 and 1200~1500-6 is part 1, 2, 3 and 4 in the diagram.

Electrical schematic diagram of the main circuit for Goodrive800-56 series 0500~0800-4, 0500~0800-5 and 0630~1000-6 is part 5 in the diagram.

Electrical schematic diagram of the main circuit for Goodrive800-56 series 1000~1200-4, 1000~1200-5 and 1200~1500-6 is part 5 and 6 in the diagram.

Sign	Terminal function
R,S,T and N	Three-phase and four-wire AC input terminals Connected to the grid, N line is not available for connection
U,V and W	Three-phase AC output terminals Generally connected to the motor, Note: U, V and W terminals of 250~1200-4, 250~1200-5 and 315~1500-6 are the output terminals of power unit.
(+) and (-)	DC output if ① is rectifier unit DC input if ② is inverter unit
PE	Grounding terminal Each machine needs to be grounded

4.2 Wiring diagram of Goodrive800-11 series inverter unit

4.2.1 Goodrive800-11 series 0004~0030-4 and 0004~0030-5

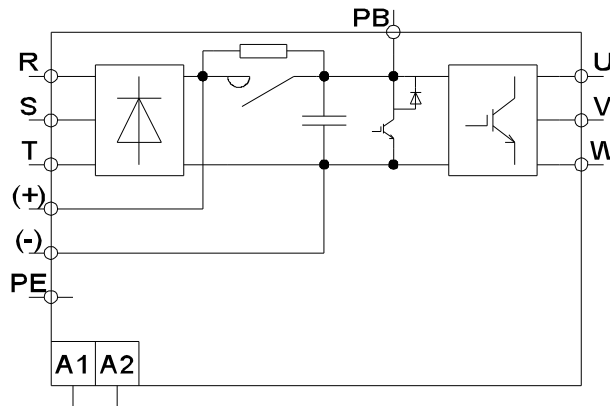

Sign	Description
R, S and T	Three-phase AC input
U, V and W	Three-phase AC output
PB and (+)	External braking resistor terminal
(+) and (-)	DC bus output
PE	Grounding terminal
A1	AC220V control power supply input L(red)
A2	AC220V control power supply input N(black)

4.2.2 Goodrive800-11 series 0037~0110-4, 0037~0110-5 and 0022~0132-6

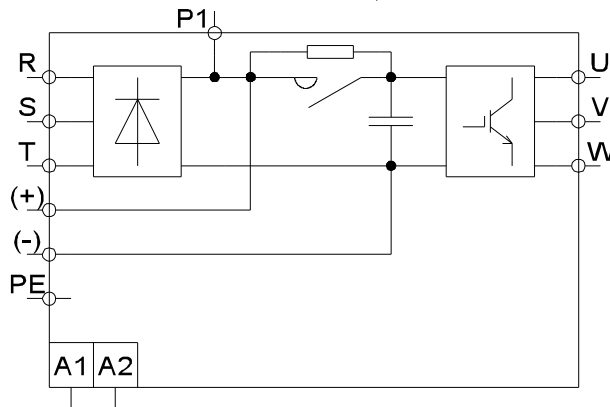

Sign	Description
R, S and T	Three-phase AC input
U, V and W	Three-phase AC output
P1 and (+)	External DC reactor terminal
(+) and (-)	DC bus output
PE	Grounding terminal
A1	AC220V control power supply input L(red)
A2	AC220V control power supply input N(black)

4.2.3 Goodrive800-11 series 0132~0200-4, 0132~0200-5 and 0160~0250-6

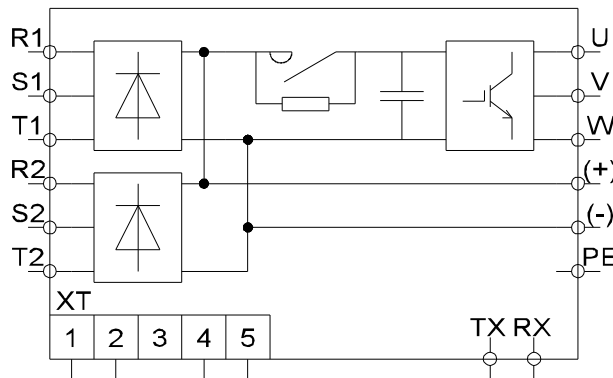

Sign	Description	
R1, S1 and T1	Three-phase AC input	
R2, S2 and T2	Three-phase AC input	
U, V and W	Three-phase AC output	
(+) and (-)	DC bus output	
PE	Grounding terminal	
XT	1	AC220V control power supply input L(red)
	2	AC220V control power supply input N(blue)
	3	Null
	4	NC contact input of reactor overtemperature. Short-connected in factory
	5	
TX	Fiber sends data, connect to RX of the control unit	
RX	Fiber receives data, connect to TX of the control unit	

Note: R1 and R2, S1 and S2 and T1 and T2 are short-connected with copper bars in factory.

4.2.4 Goodrive800-11 series 0250~0400-4, 0250~0400-5 and 0315~0500-6

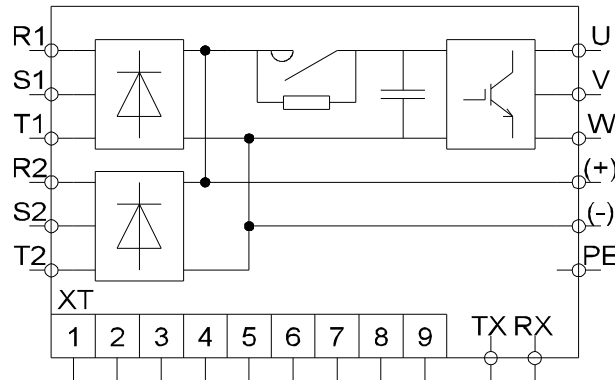

Sign	Description	Remark	
R1, S1 and T1	Three-phase AC input		
R2, S2 and T2	Three-phase AC input		
U, V and W	Three-phase AC output		
(+) and (-)	DC bus output		
PE	Grounding terminal		
XT	1	A phase of the power supply for AC380V fan (yellow)	Notice the sequence of the fan. The rotating direction is the same as the designated direction
	2	B phase of the power supply for AC380V fan (green)	
	3	C phase of the power supply for AC380V fan (red)	
	4	AC220V control power supply input L(red)	Can not be connected in reverse
	5	AC220V control power supply input N(blue)	
	6	Control power supply output L(connect to the A phase)(orange)	
	7	Control power supply output N(blue)	
	8	NC contact input of external fault. Short-connected in factory (black)	According to the application
	9		
TX	Fiber sends data, connect to RX of the control unit		
RX	Fiber receives data, connect to TX of the control unit		

Note: R1 and R2, S1 and S2 and T1 and T2 are short-connected with capper bars in factory.

4.3 Wiring diagram of Goodrive800-51 series converting unit

4.3.1 Goodrive800-51 series 0075~0110-4, 0075~0110-5 and 0075~0132-6

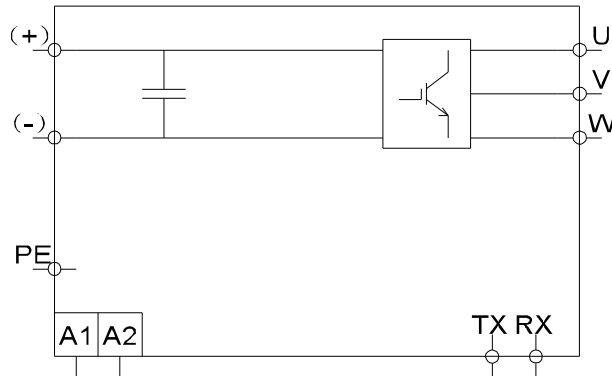

Sign	Description
U, V and W	Three-phase AC input if ① is the rectification unit Three-phase AC output if ② is the converting unit
(+) and (-)	DC bus output if ① is the rectification unit DC bus input if ② is the converting unit
PE	Grounding terminal
A1	AC220V control power supply input L(red)
A2	AC220V control power supply input N(black)
TX	Fiber sends data, connect to RX of the control unit
RX	Fiber receives data, connect to TX of the control unit

4.3.2 Goodrive800-51 series 0132~0200-4, 0132~0200-5 and 0160~0250-6

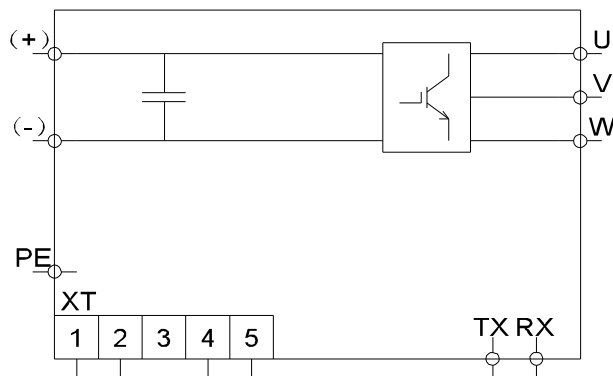

Sign	Description
U, V and W	Three-phase AC input if ① is the rectification unit Three-phase AC output if ② is the converting unit
(+) and (-)	DC bus output if ① is the rectification unit DC bus input if ② is the converting unit
PE	Grounding terminal
XT	1 AC220V control power supply input L(red)
	2 AC220V control power supply input N(blue)
	3 Null
	4 NC contact input of external fault. Short-connected in factory (black)
	5
TX	Fiber sends data, connect to RX of the control unit
RX	Fiber receives data, connect to TX of the control unit

4.3.3 Goodrive800-51 series 0250~0400-4, 0250~0400-5 and 0315~0500-6

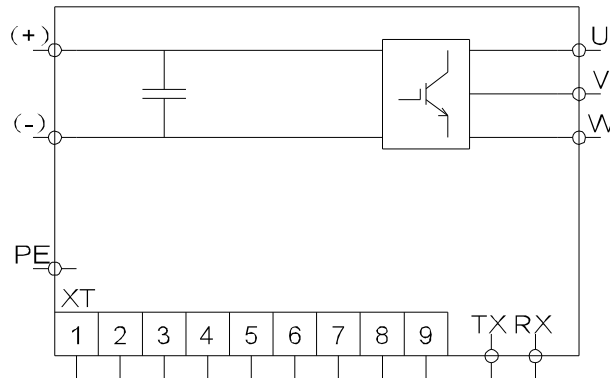

Sign	Description	Remark	
U, V and W	Three-phase AC input if ① is the rectification unit Three-phase AC output if ② is the convertering unit		
(+) and (-)	DC bus output if ① is the rectification unit DC bus input if ② is the convertering unit		
PE	Grounding terminal		
XT	1	A phase of the power supply for AC380V fan (yellow)	Notice the sequence of the fan. The rotating direction is the same as the designated direction
	2	B phase of the power supply for AC380V fan (green)	
	3	C phase of the power supply for AC380V fan (red)	
	4	AC220V control power supply input L(red)	Can not be connected in reverse
	5	AC220V control power supply input N(blue)	
	6	Control power supply output L(connect to the A phase)(orange)	Generally the control power input of filter unit
	7	Control power supply output N(blue)	
	8	NC contact input of external fault. Short-connected in factory	According to the application
	9		
TX	Fiber sends data, connect to RX of the control unit		
RX	Fiber receives data, connect to TX of the control unit		

4.4 Wiring diagram of Goodrive800-61 series diode rectification unit

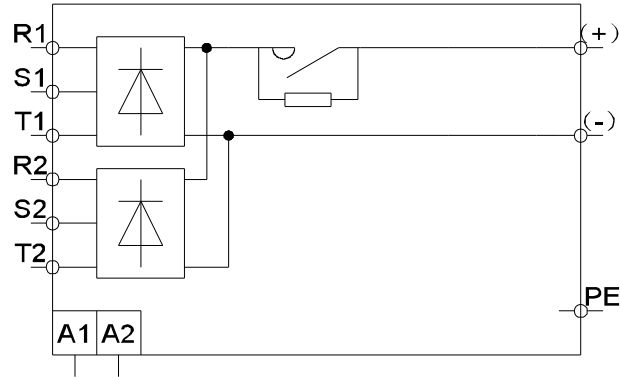

Sign	Description
R1, S1 and T1	Three-phase AC input
R2, S2 and T2	Three-phase AC input
(+) and (-)	DC bus output
PE	Grounding terminal
A1	AC220V control power supply input L(red)
A2	AC220V control power supply input N(black)

Note: R1 and R2, S1 and S2 and T1 and T2 are short-connected with copper bars in factory.

4.5 Wiring diagram of Goodrive800-71 series silicon-controlled rectification unit

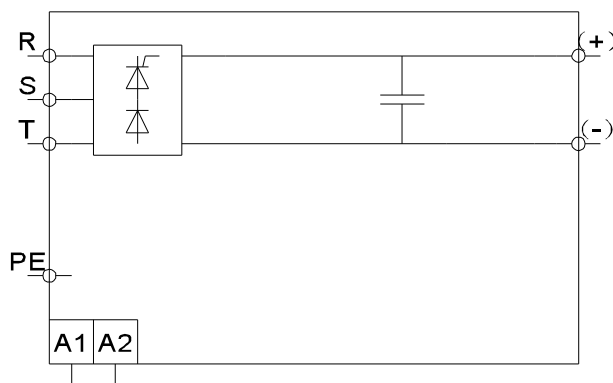

Sign	Description
R, S and T	Three-phase AC input
(+) and (-)	DC bus output
PE	Grounding terminal
A1	AC220V control power supply input L(red)
A2	AC220V control power supply input N(black)

4.6 Wiring diagram of Goodrive800-81 series IGBT synchronous rectification unit

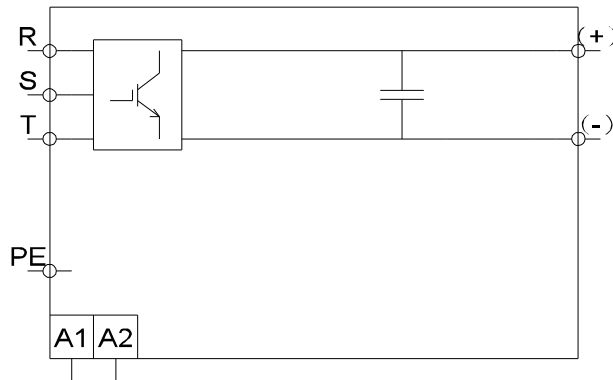

Sign	Description
R, S and T	Three-phase AC input
(+) and (-)	DC bus output
PE	Grounding terminal
A1	AC220V control power supply input L(red)
A2	AC220V control power supply input N(black)

4.7 Wiring diagram of Goodrive800-01 series LCL PWM filter unit

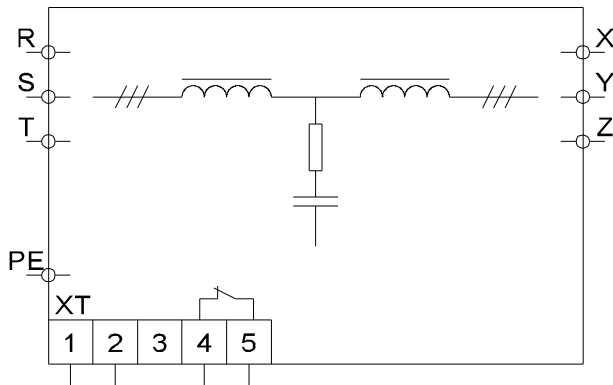

Sign	Description	
R, S and T	Reactor three-phase input at grid side	
X, Y and Z	Three-phase output at the rectification side	
XT	1	AC220V control power supply input L(red)
	2	AC220V control power supply input N(blue)
	3	Null
	4	NC contact output of reactor overtemperature.(black)
	5	

4.8 Wiring diagram of Goodrive800-02 series sine wave filter unit

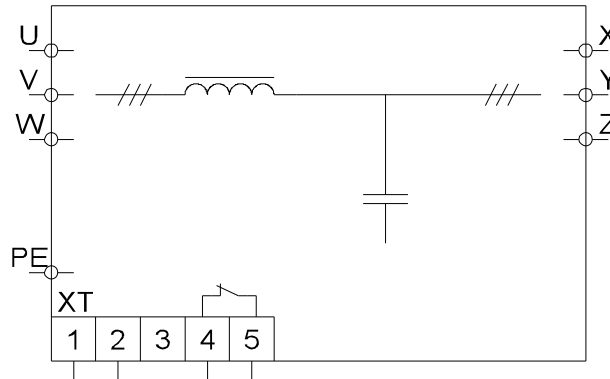

Sign	Description	
R, S and T	Reactor three-phase input at grid side	
X, Y and Z	Three-phase output	
PE	Grounding terminal	
XT	1	AC220V control power supply input L(red)
	2	AC220V control power supply input N(blue)
	3	Null
	4	NC contact output of overtemperature.(black)
	5	

4.9 Wiring diagram of Goodrive800-03 series bus capacitor energy storage/filter unit

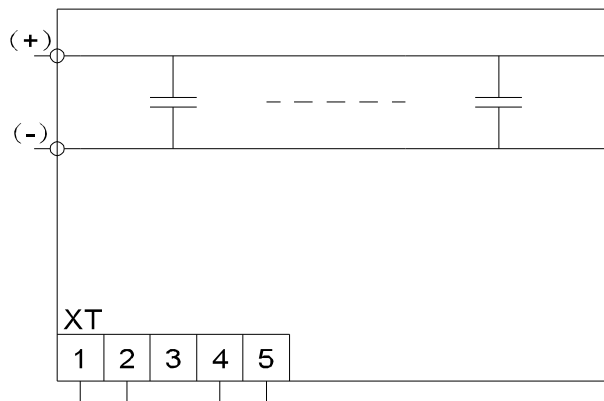

Sign	Description	
(+) and (-)	DC bus output	
XT	1	AC220V control power supply input L(red)
	2	AC220V control power supply input N(blue)
	3	Null
	4	NC contact output of overtemperature.(black)
	5	

4.10 Schematic diagram of Goodrive800 series control units

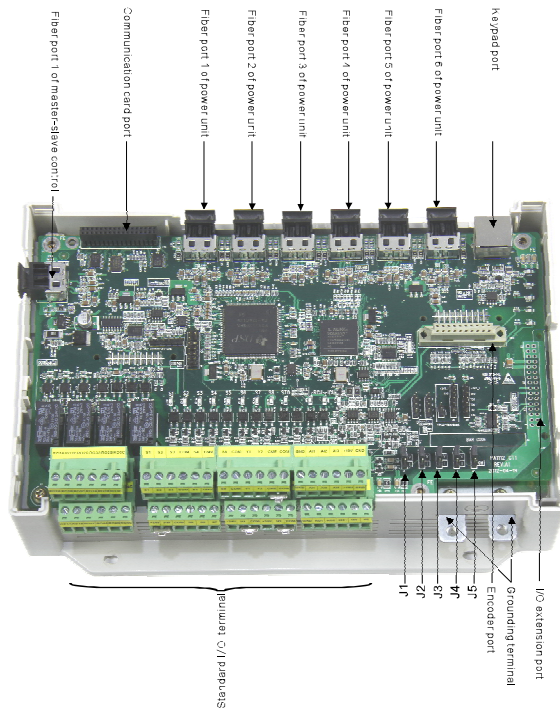
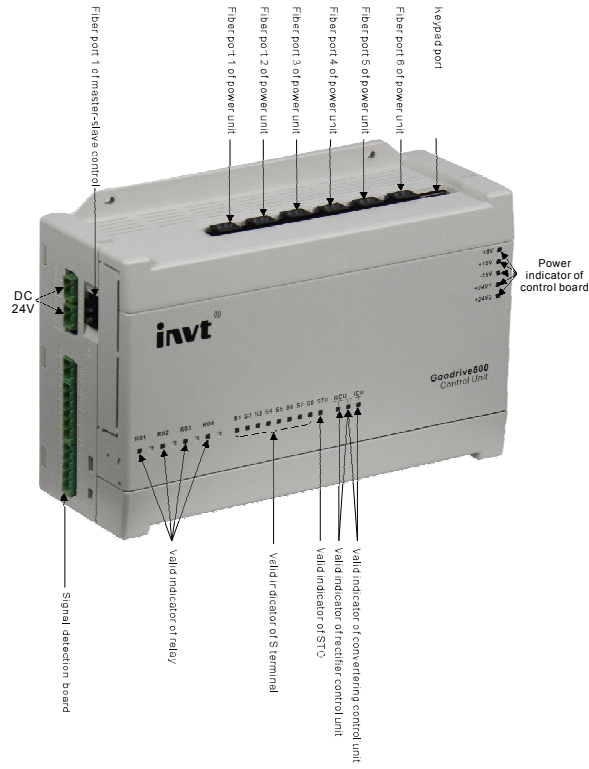

Note: The control board is installed in the control box.

4.10.1 Wiring of control circuit

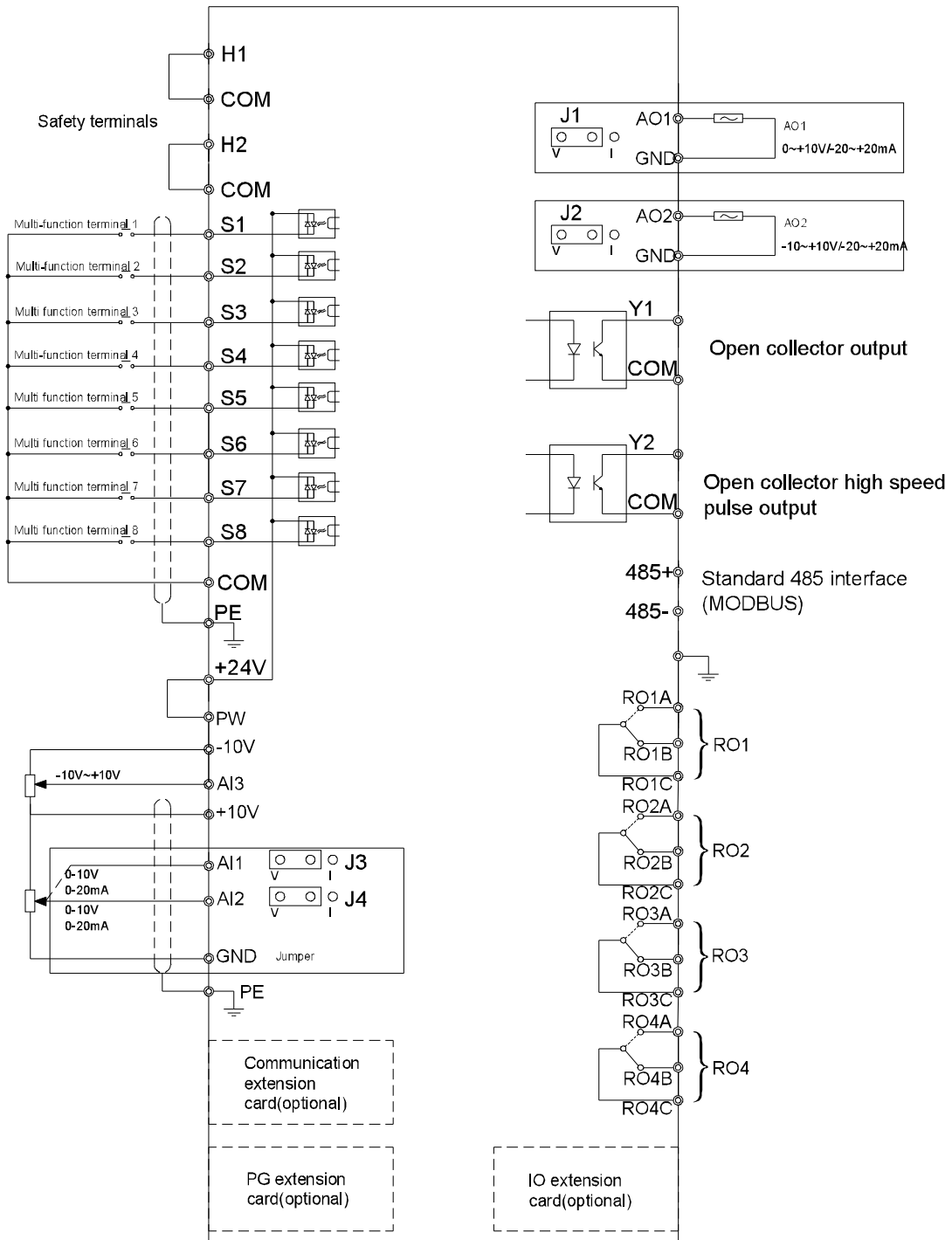

Note: Above terminals are not the terminals on extension card. It is necessary to select the communication extension card, IO extension card, PG card, RST detection board and temperature detection board according to actual requirement for Goodrive800 series products.

4.10.2 Control terminals

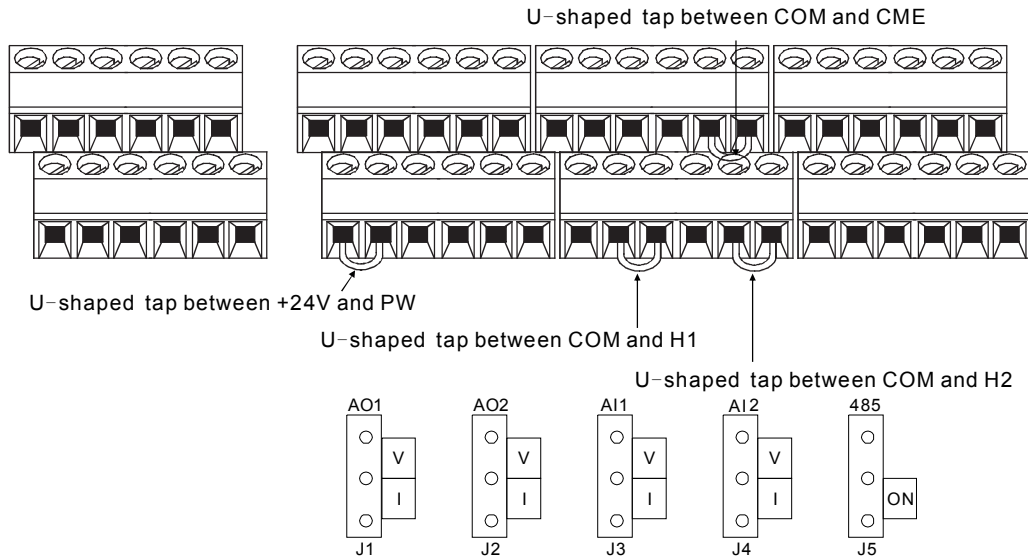

RO2A	RO2B	RO2C	RO3A	RO3B	RO3C	S1	S2	S3	COM	S4	+24V	S8	COM	Y1	Y2	CME	COM	GND	AI1	AI2	AI3	+10V	GND
RO1A	RO1B	RO1C	RO4A	RO4B	RO4C	+24V	PW	COM	S5	S6	S7	+24V	H1	COM	+24V	H2	COM	GND	AO1	AO2	485+	485-	PE

Type	Sign	Name	Function
Power supply	+10V	10V power supply	Local 10.5V reference power supply
	+24V	24V power supply	24V Max. output current 200mA
	PW	External power supply	External power supply Range: 12~24V
	GND	Ground	+10V reference zero potential
	COM	+24V common terminal	+24V common terminal
Analog input	AI1	Analog input 1	1. Input range: 0~10V or 0~20mA 2. Input/current input is determined by J3
	AI2	Analog input 2	1. Input range: 0~10V or 0~20mA 2. Input/current input is determined by J4
	AI3	Analog input 3	1. Input range: -10~10V
Analog output	AO1	Analog output 1	1. Input range: 0~10V or 0~20mA 2. Input/current input is determined by J1
	AO2	Analog output 2	1. Input range: 0~10V or 0~20mA 2. Input/current input is determined by J2
Digital input	S1	Digital input 1	1. Input impedance: 3.3kΩ 2. Voltage input range: 12~30V 3. Support NPN and PNP
	S2	Digital input 2	
	S3	Digital input 3	
	S4	Digital input 4	
	S5	Digital input 5	
	S6	Digital input 6	
	S7	Digital input 7	

Type	Sign	Name	Function
	S8	Digital input 8	Besides the function of S1~S7, it can be as the high frequency pulse input channel Maximum input frequency: 50kHz
Digital output	Y1	Collector output 1	1.Switching capacity: 200mA/30V 2.Output frequency range: 0-1kHz
	Y2	Collector output 2	1. Switching capacity: 1A/30V 2. Output frequency range: 0~50kHz
Safety function	H1	Safe input 1	Short-connected with COM terminal in factory. Remove the connection wires between H1 and COM, H2 and COM if safety input is used.
	H2	Safe input 2	
Relay output	RO1A	Relay 1 NO contact	1. Contact capacity: AC250V/3A, DC30V/1A 2. Can not be used as the high frequency switch output Note: If H1 or H2 input is valid for STO function, then RO4 is forced output and can be used as common relay.
	RO1B	Relay 1 NC contact	
	RO1C	Relay 1 common contact	
	RO2A	Relay 2 NO contact	
	RO2B	Relay 2 NC contact	
	RO2C	Relay 2 common contact	
	RO3A	Relay 3 NO contact	
	RO3B	Relay 3 NC contact	
	RO3C	Relay 3 common contact	
	RO4A	Relay 4 NO contact	
	RO4B	Relay 4 NC contact	
	RO4C	Relay 4 common contact	
Communication	485+	485 communication	485 communication terminal
	485-		Apply MODBUS protocol J5 can select whether to connect 120Ω terminal resistor

4.11 Goodrive800-51 series unit control board

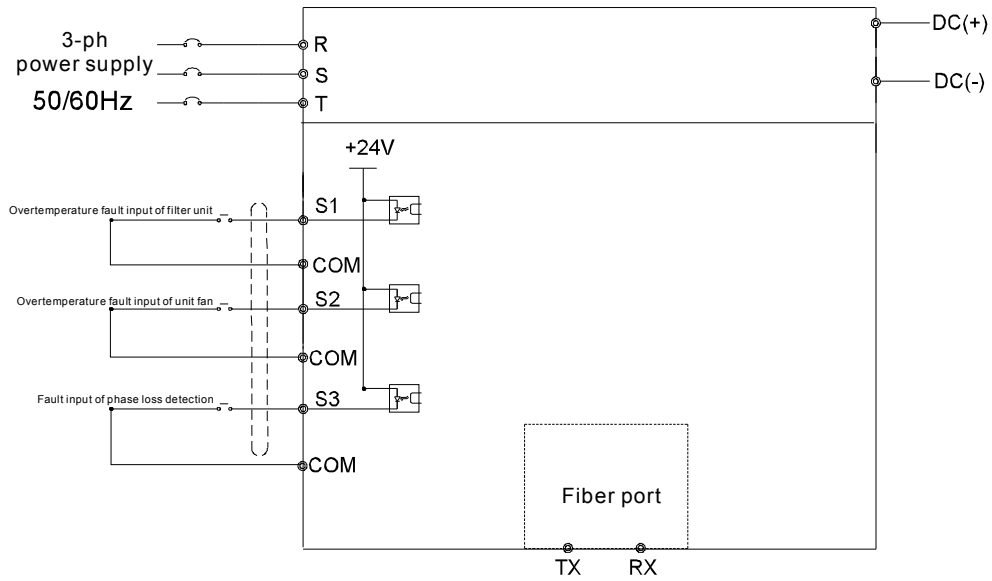

Type	Sign	Name	Function
Power supply	COM	+24V common terminal	+24V common terminal
Digital input	S1	Analog input 1	1. Input impedance: 3.3kΩ 2. Voltage input range: 12~30V 3. No need to short-connected
	S2	Analog input 2	
	S3	Analog input 3	

4.12 Goodrive800-61, Goodrive800-71, Goodrive800-81 and Goodrive800-91 series rectification control board

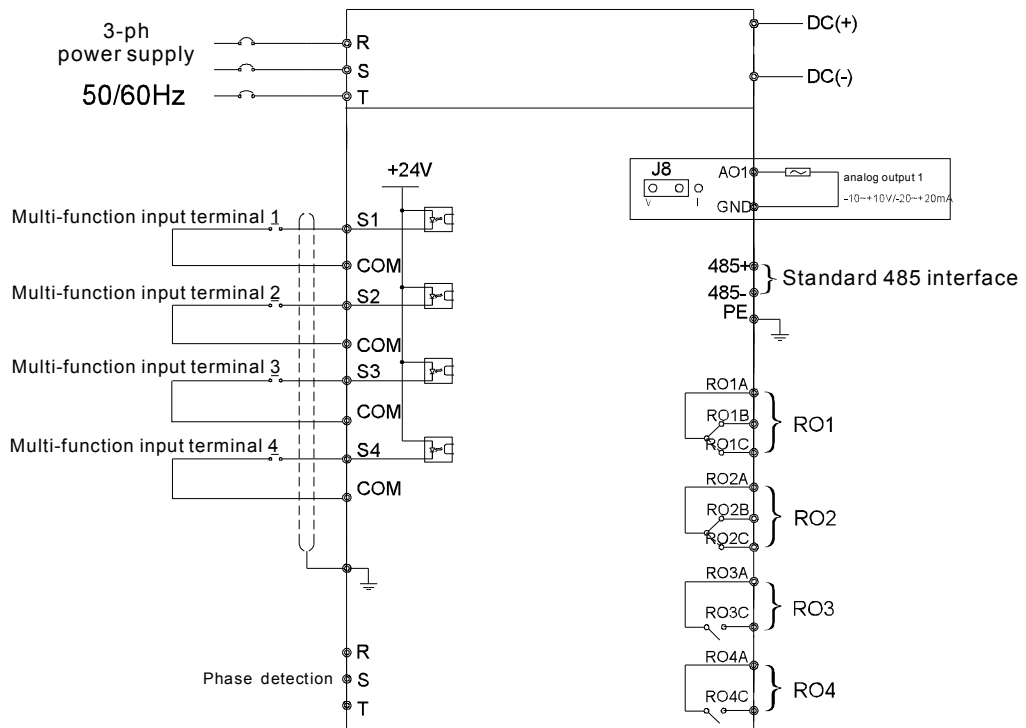

Type	Sign	Name	Function
Analog output	AO	Analog output	1. Output range: 0~10V or 0~20mA 2. The output is determined by J8
Power supply	COM	+24V common terminal	+24V common terminal
	GND	Reference grounding	Reference grounding of AO
Digital input	S1	Analog input 1	1. Input impedance: 3.3kΩ 2. Voltage input range: 12~30V
	S2	Analog input 2	
	S3	Analog input 3	
	S4	Analog input 4	
Relay output	RO1A	Relay 1 NO contact	1. Contact capacity: AC250V/6A, DC30V/6A 2. Not used as high frequency switch output (pay attention to it)
	RO1B	Relay 1 NC contact	
	RO1C	Relay 1 common contact	
	RO2A	Relay 2 NO contact	
	RO2B	Relay 2 NC contact	
	RO2C	Relay 2 common contact	
	RO3A	Relay 3 NO contact	1. Contact capacity: AC250V/6A 2. System control; RO3 is the control signal of main contactor RO4 is the control signal of buffer contactor
	RO3C	Relay 3 common contact	
	RO4A	Relay 4 NO contact	
	RO4C	Relay 4 common contact	
Communication	485+ and 485-	485 communication	485 communication terminal, apply MODBUS protocol
Phase detection	R, S and T	Phase detection	Phase detection function

Chapter 5 Configuration table of the cabinets

5.1 Configuration table of Goodrive800-26 series products

Model	Rectification		Converting	
	Quantity	Specifications	Quantity	Specifications
U_N = 380 V				
GD800-26-0075-4	GD800-96-0075-4	1	GD800-51-0075-4*	1
GD800-26-0090-4	GD800-96-0090-4	1	GD800-51-0090-4*	1
GD800-26-0110-4	GD800-96-0110-4	1	GD800-51-0110-4*	1
GD800-26-0132-4	GD800-96-0132-4	1	GD800-51-0132-4*	1
GD800-26-0160-4	GD800-96-0160-4	1	GD800-51-0160-4*	1
GD800-26-0200-4	GD800-96-0200-4	1	GD800-51-0200-4*	1
GD800-26-0250-4	GD800-96-0250-4	1	GD800-56-0250-4	1
GD800-26-0315-4	GD800-96-0315-4	1	GD800-56-0315-4	1
GD800-26-0400-4	GD800-96-0400-4	1	GD800-56-0400-4	1
GD800-26-0500-4	GD800-96-0500-4	1	GD800-56-0500-4	1
GD800-26-0630-4	GD800-96-0630-4	1	GD800-56-0630-4	1
GD800-26-0800-4	GD800-96-0800-4	1	GD800-56-0800-4	1
GD800-26-1000-4	GD800-96-1000-4	1	GD800-56-1000-4	1
GD800-26-1200-4	GD800-96-1200-4	1	GD800-56-1200-4	1
U_N = 500 V				
GD800-26-0075-5	GD800-96-0075-5	1	GD800-51-0075-5*	1
GD800-26-0090-5	GD800-96-0090-5	1	GD800-51-0090-5*	1
GD800-26-0110-5	GD800-96-0110-5	1	GD800-51-0110-5*	1
GD800-26-0132-5	GD800-96-0132-5	1	GD800-51-0132-5*	1
GD800-26-0160-5	GD800-96-0160-5	1	GD800-51-0160-5*	1
GD800-26-0200-5	GD800-96-0200-5	1	GD800-51-0200-5*	1
GD800-26-0250-5	GD800-96-0250-5	1	GD800-56-0250-5	1
GD800-26-0315-5	GD800-96-0315-5	1	GD800-56-0315-5	1
GD800-26-0400-5	GD800-96-0400-5	1	GD800-56-0400-5	1
GD800-26-0500-5	GD800-96-0500-5	1	GD800-56-0500-5	1
GD800-26-0630-5	GD800-96-0630-5	1	GD800-56-0630-5	1
GD800-26-0800-5	GD800-96-0800-5	1	GD800-56-0800-5	1
GD800-26-1000-5	GD800-96-1000-5	1	GD800-56-1000-5	1
GD800-26-1200-5	GD800-96-1200-5	1	GD800-56-1200-5	1
U_N = 660 V				
GD800-26-0075-6	GD800-96-0075-6	1	GD800-51-0075-6*	1
GD800-26-0090-6	GD800-96-0090-6	1	GD800-51-0090-6*	1
GD800-26-0110-6	GD800-96-0110-6	1	GD800-51-0110-6*	1

Model	Rectification		Convertering	
	Quantity	Specifications	Quantity	Specifications
GD800-26-0132-6	GD800-96-0132-6	1	GD800-51-0132-6*	1
GD800-26-0160-6	GD800-96-0160-6	1	GD800-51-0160-6*	1
GD800-26-0200-6	GD800-96-0200-6	1	GD800-51-0200-6*	1
GD800-26-0250-6	GD800-96-0250-6	1	GD800-51-0250-6*	1
GD800-26-0315-6	GD800-96-0315-6	1	GD800-56-0315-6	1
GD800-26-0400-6	GD800-96-0400-6	1	GD800-56-0400-6	1
GD800-26-0500-6	GD800-96-0500-6	1	GD800-56-0500-6	1
GD800-26-0630-6	GD800-96-0630-6	1	GD800-56-0630-6	1
GD800-26-0800-6	GD800-96-0800-6	1	GD800-56-0800-6	1
GD800-26-1000-6	GD800-96-1000-6	1	GD800-56-1000-6	1
GD800-26-1200-6	GD800-96-1200-6	1	GD800-56-1200-6	1
GD800-26-1500-6	GD800-96-1500-6	1	GD800-56-1500-6	1

Note: The model marked with "*" means power unit+control unit.

For example "GD800-51-0075-4*" means GD800-51-0075-4+ GD800-ICU-0075-4

5.2 Configuration table of Goodrive800-96 series products

Model	Rectification unit		LCL Filtering unit		Rectification control unit	
	Specifications	Quantity	Specifications	Quantity	Specifications	Quantity
U_N = 380 V						
GD800-96-0075-4	GD800-51-0075-4	1	/		GD800-RCU-007 5-4	1
GD800-96-0090-4	GD800-51-0090-4	1	/		GD800-RCU-009 0-4	1
GD800-96-0110-4	GD800-51-0110-4	1	/		GD800-RCU-011 0-4	1
GD800-96-0132-4	GD800-51-0132-4	1	/		GD800-RCU-013 2-4	1
GD800-96-0160-4	GD800-51-0160-4	1	/		GD800-RCU-016 0-4	1
GD800-96-0200-4	GD800-51-0200-4	1	/		GD800-RCU-020 0-4	1
GD800-96-0250-4	GD800-51-0250-4	1	GD800-01-0250-4	1	GD800-RCU-025 0-4	1
GD800-96-0315-4	GD800-51-0315-4	1	GD800-01-0315-4	1	GD800-RCU-031 5-4	1
GD800-96-0400-4	GD800-51-0400-4	1	GD800-01-0400-4	1	GD800-RCU-040 0-4	1
GD800-96-0500-4	GD800-51-0250-4	2	GD800-01-0250-4	2	GD800-RCU-050 0-4	1
GD800-96-0630-4	GD800-51-0315-4	2	GD800-01-0315-4	2	GD800-RCU-063 0-4	1
GD800-96-0800-4	GD800-51-0400-4	2	GD800-01-0400-4	2	GD800-RCU-080 0-4	1
GD800-96-1000-4	GD800-51-0315-4	3	GD800-01-0315-4	3	GD800-RCU-100 0-4	1
GD800-96-1200-4	GD800-51-0400-4	3	GD800-01-0400-4	3	GD800-RCU-120 0-4	1
U_N = 500 V						
GD800-96-0075-5	GD800-51-0075-5	1	/		GD800-RCU-007 5-5	1
GD800-96-0090-5	GD800-51-0090-5	1	/		GD800-RCU-009 0-5	1
GD800-96-0110-5	GD800-51-0110-5	1	/		GD800-RCU-011 0-5	1
GD800-96-0132-5	GD800-51-0132-5	1	/		GD800-RCU-013 2-5	1
GD800-96-0160-5	GD800-51-0160-5	1	/		GD800-RCU-016	1

Model	Rectification unit		LCL Filtering unit		Rectification control unit	
	Specifications	Quantity	Specifications	Quantity	Specifications	Quantity
					0-5	
GD800-96-0200-5	GD800-51-0200-5	1	/		GD800-RCU-020 0-5	1
GD800-96-0250-5	GD800-51-0250-5	1	GD800-01-0250-5	1	GD800-RCU-025 0-5	1
GD800-96-0315-5	GD800-51-0315-5	1	GD800-01-0315-5	1	GD800-RCU-031 5-5	1
GD800-96-0400-5	GD800-51-0400-5	1	GD800-01-0400-5	1	GD800-RCU-040 0-5	1
GD800-96-0500-5	GD800-51-0250-5	2	GD800-01-0250-5	2	GD800-RCU-050 0-5	1
GD800-96-0630-5	GD800-51-0315-5	2	GD800-01-0315-5	2	GD800-RCU-063 0-5	1
GD800-96-0800-5	GD800-51-0400-5	2	GD800-01-0400-5	2	GD800-RCU-080 0-5	1
GD800-96-1000-5	GD800-51-0315-5	3	GD800-01-0315-5	3	GD800-RCU-100 0-5	1
GD800-96-1200-5	GD800-51-0400-5	3	GD800-01-0400-5	3	GD800-RCU-120 0-5	1
U_N = 660 V						
GD800-96-0075-6	GD800-51-0075-6	1	/		GD800-RCU-007 5-6	1
GD800-96-0090-6	GD800-51-0090-6	1	/		GD800-RCU-009 0-6	1
GD800-96-0110-6	GD800-51-0110-6	1	/		GD800-RCU-011 0-6	1
GD800-96-0132-6	GD800-51-0132-6	1	/		GD800-RCU-013 2-6	1
GD800-96-0160-6	GD800-51-0160-6	1	/		GD800-RCU-016 0-6	1
GD800-96-0200-6	GD800-51-0200-6	1	/		GD800-RCU-020 0-6	1
GD800-96-0250-6	GD800-51-0250-6	1	/		GD800-RCU-025 0-6	1
GD800-96-0315-6	GD800-51-0315-6	1	GD800-01-0315-6	1	GD800-RCU-031 5-6	1
GD800-96-0400-6	GD800-51-0400-6	1	GD800-01-0400-6	1	GD800-RCU-040 0-6	1
GD800-96-0500-6	GD800-51-0500-6	1	GD800-01-0500-6	1	GD800-RCU-050 0-6	1
GD800-96-0630-6	GD800-51-0315-6	2	GD800-01-0315-6	2	GD800-RCU-063	1

Model	Rectification unit		LCL Filtering unit		Rectification control unit	
	Specifications	Quantity	Specifications	Quantity	Specifications	Quantity
					0-6	
GD800-96-0800-6	GD800-51-0400-6	2	GD800-01-0400-6	2	GD800-RCU-080 0-6	1
GD800-96-1000-6	GD800-51-0500-6	2	GD800-01-0500-6	2	GD800-RCU-100 0-6	1
GD800-96-1200-6	GD800-51-0400-6	3	GD800-01-0400-6	3	GD800-RCU-120 0-6	1
GD800-96-1500-6	GD800-51-0500-6	3	GD800-01-0500-6	3	GD800-RCU-150 0-6	1

5.3 Configuration table of Goodrive800-56 series products

Model	IGBT		Converting control unit	
	Specifications	Quantity	Specifications	Quantity
U_N =380 V				
GD800-56-0132-4	GD800-51-0132-4	1	GD800-ICU-0132-4	1
GD800-56-0160-4	GD800-51-0160-4	1	GD800-ICU-0160-4	1
GD800-56-0200-4	GD800-51-0200-4	1	GD800-ICU-0200-4	1
GD800-56-0250-4	GD800-51-0250-4	1	GD800-ICU-0250-4	1
GD800-56-0315-4	GD800-51-0315-4	1	GD800-ICU-0315-4	1
GD800-56-0400-4	GD800-51-0400-4	1	GD800-ICU-0400-4	1
GD800-56-0500-4	GD800-51-0250-4	2	GD800-ICU-0500-4	1
GD800-56-0630-4	GD800-51-0315-4	2	GD800-ICU-0630-4	1
GD800-56-0800-4	GD800-51-0400-4	2	GD800-ICU-0800-4	1
GD800-56-1000-4	GD800-51-0315-4	3	GD800-ICU-1000-4	1
GD800-56-1200-4	GD800-51-0400-4	3	GD800-ICU-1200-4	1
U_N =500 V				
GD800-56-0132-5	GD800-51-0132-5	1	GD800-ICU-0132-5	1
GD800-56-0160-5	GD800-51-0160-5	1	GD800-ICU-0160-5	1
GD800-56-0200-5	GD800-51-0200-5	1	GD800-ICU-0200-5	1
GD800-56-0250-5	GD800-51-0250-5	1	GD800-ICU-0250-5	1
GD800-56-0315-5	GD800-51-0315-5	1	GD800-ICU-0315-5	1
GD800-56-0400-5	GD800-51-0400-5	1	GD800-ICU-0400-5	1
GD800-56-0500-5	GD800-51-0250-5	2	GD800-ICU-0500-5	1
GD800-56-0630-5	GD800-51-0315-5	2	GD800-ICU-0630-5	1
GD800-56-0800-5	GD800-51-0400-5	2	GD800-ICU-0800-5	1
GD800-56-1000-5	GD800-51-0315-5	3	GD800-ICU-1000-5	1
GD800-56-1200-5	GD800-51-0400-5	3	GD800-ICU-1200-5	1
U_N =660 V				
GD800-56-0160-6	GD800-51-0160-6	1	GD800-ICU-0160-6	1
GD800-56-0200-6	GD800-51-0200-6	1	GD800-ICU-0200-6	1
GD800-56-0250-6	GD800-51-0250-6	1	GD800-ICU-0250-6	1
GD800-56-0315-6	GD800-51-0315-6	1	GD800-ICU-0315-6	1
GD800-56-0400-6	GD800-51-0400-6	1	GD800-ICU-0400-6	1
GD800-56-0500-6	GD800-51-0500-6	1	GD800-ICU-0500-6	1
GD800-56-0630-6	GD800-51-0315-6	2	GD800-ICU-0630-6	1
GD800-56-0800-6	GD800-51-0400-6	2	GD800-ICU-0800-6	1
GD800-56-1000-6	GD800-51-0500-6	2	GD800-ICU-1000-6	1
GD800-56-1200-6	GD800-51-0400-6	3	GD800-ICU-1200-6	1
GD800-56-1500-6	GD800-51-0500-6	3	GD800-ICU-1500-6	1

Chapter 6 Main components

6.1 Goodrive800 series cabinet products

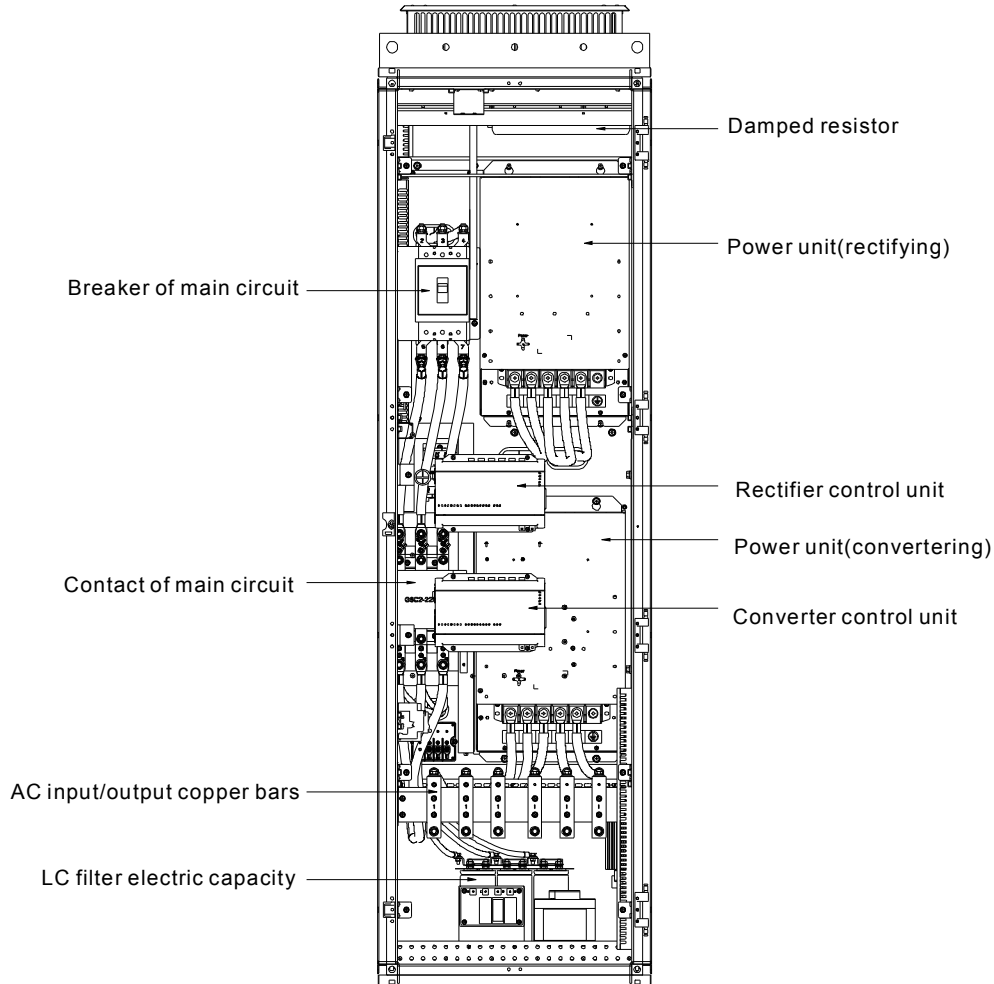

Components layout diagram of Goodrive800-26 series 0075~0110-4, 0075~0110-5 and 0075~0132-6

Components layout diagram of Goodrive800-96 series 0075~0110-4, 0075~0110-5 and 0075~0132-6 is the diagram without IGBT, convertering control unit and AC output copper bars

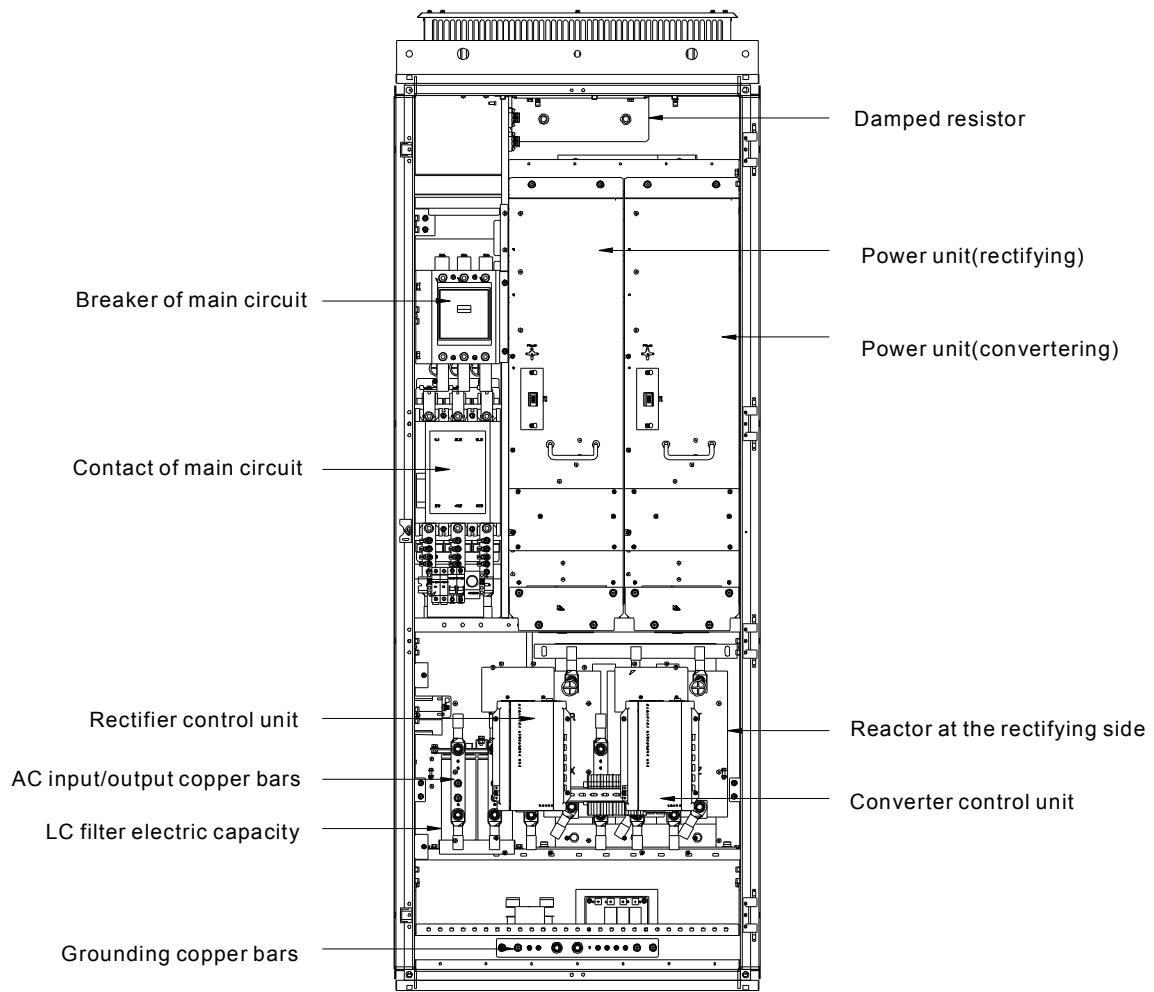

Components layout diagram of Goodrive800-26 series 0132~0200-4, 0132~0200-5 and 0160~0250-6

Components layout diagram of Goodrive800-96 series 0132~0200-4, 0132~0200-5 and 0160~0250-6 is the diagram without power unit, convertering control unit and AC output copper bars.

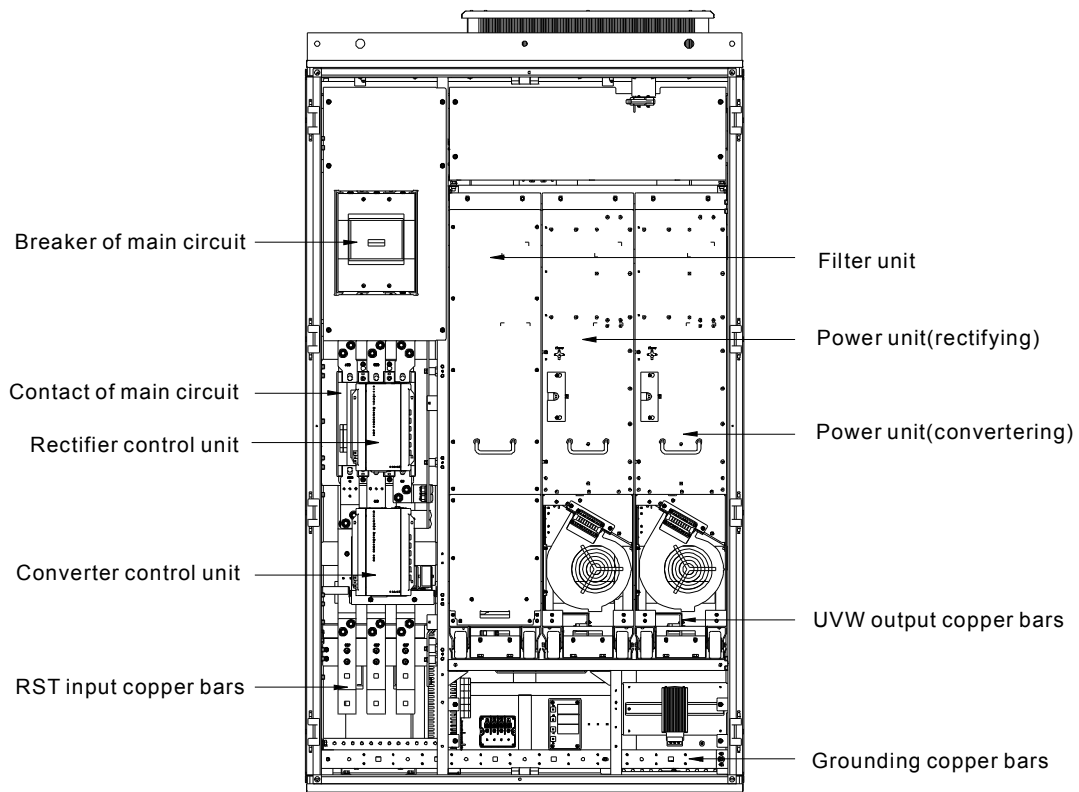

Components layout diagram of Goodrive800-26 series 0250~0400-4, 0250~0400-5 and 0315~0500-6

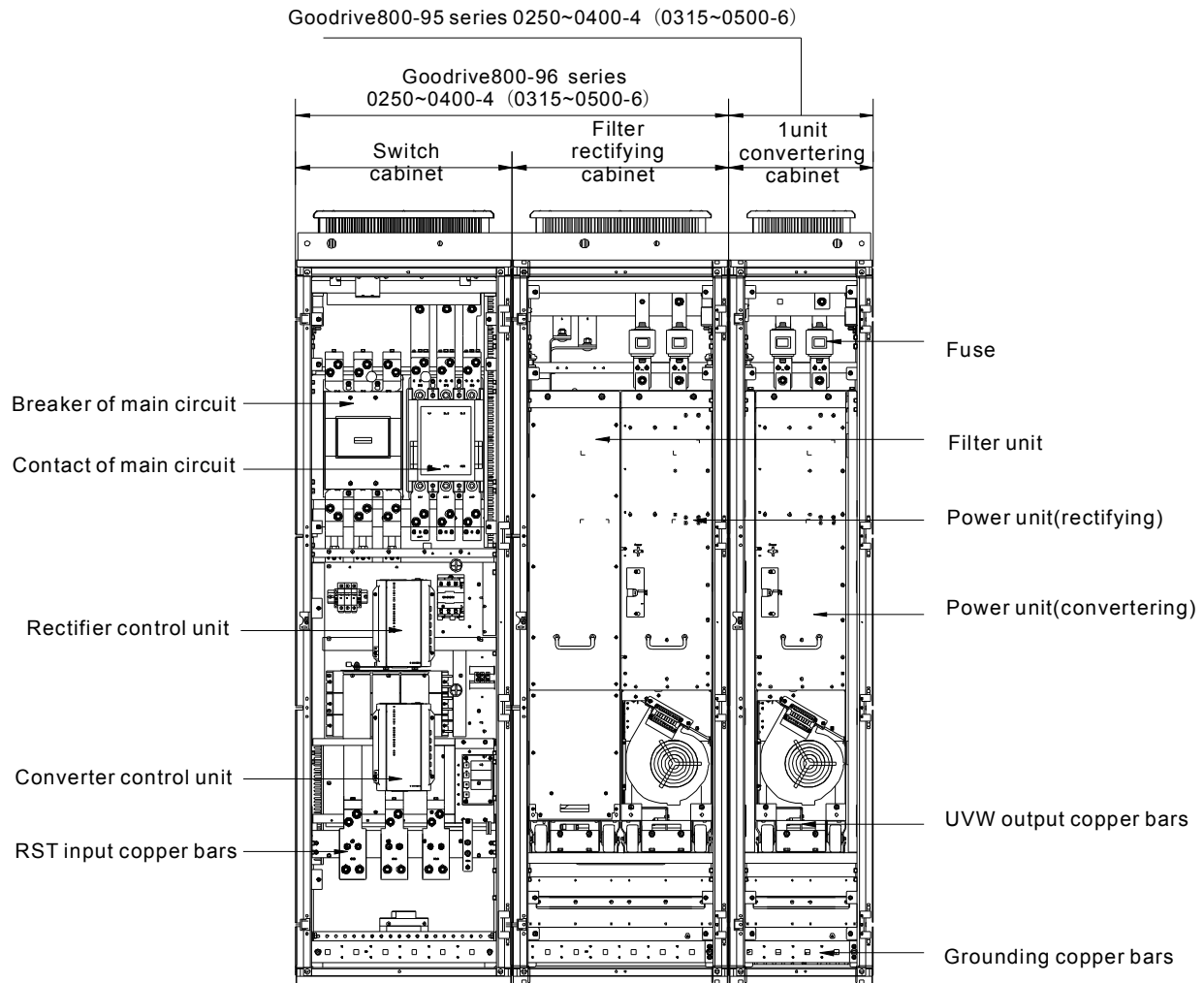

Components layout diagram of Goodrive800-26 series 0250~0400-4, 0250~0400-5 and 0315~0500-6

Components layout diagram of Goodrive800-96 series 0250~0400-4, 0250~0400-5 and 0315~0500-6 is the diagram without converting cabinet and converting control unit

Components layout diagram of Goodrive800-56 series 0250~0400-4, 0250~0400-5 and 0315~0500-6 is the diagram without filter rectifier cabinet and switch cabinet

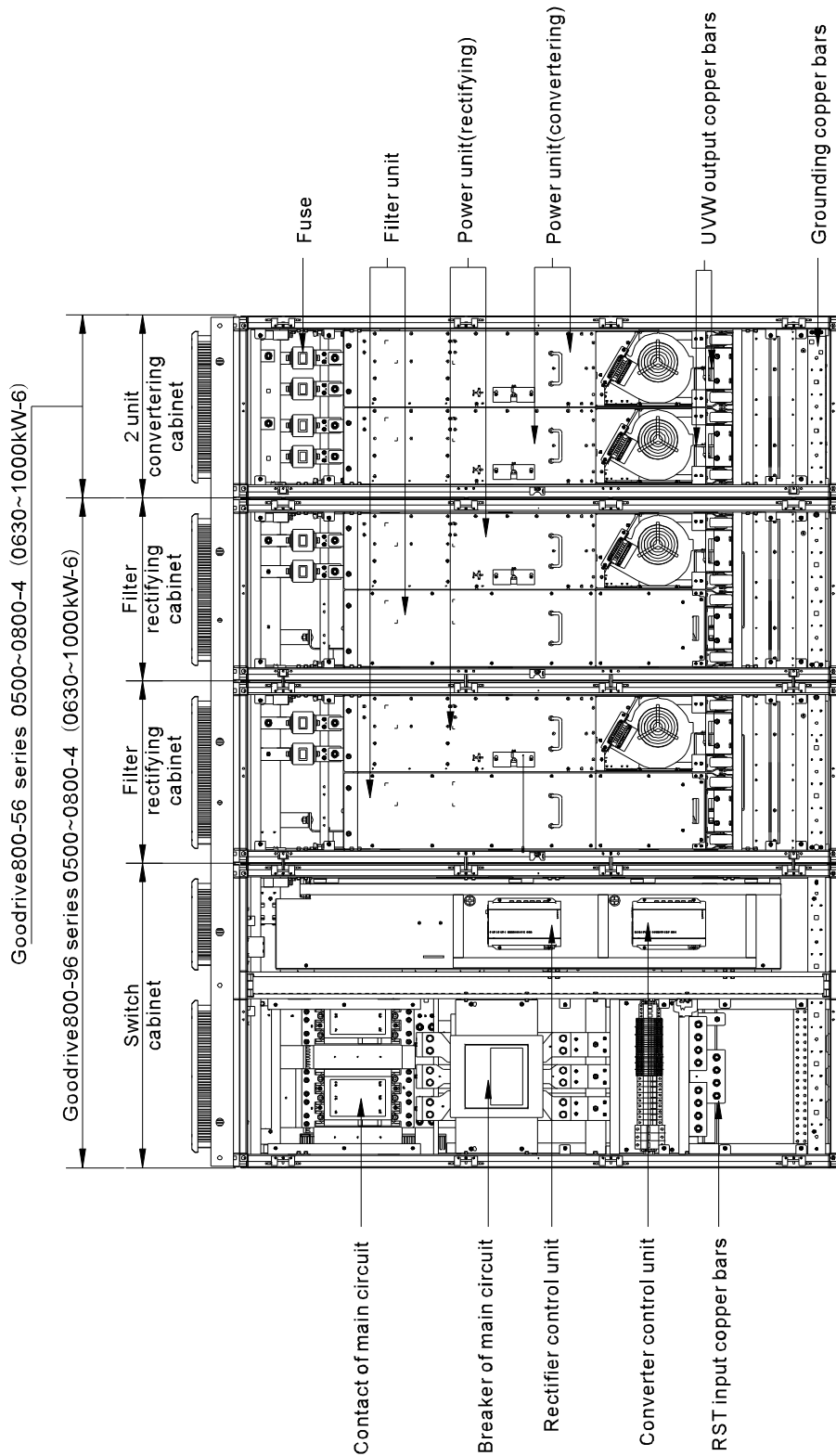

Components layout diagram of Goodrive800-26 series 0500~0800-4, 0500~0800-5 and 0630~1000-6

Components layout diagram of Goodrive800-96 series 0500~0800-4, 0500~0800-5 and 0630~1000-6 is the diagram without converting cabinet and converting control unit

Components layout diagram of Goodrive800-56 series 0500~0800-4, 0500~0800-5 and 0630~1000-6 is the diagram without filter rectifier cabinet and switch cabinet

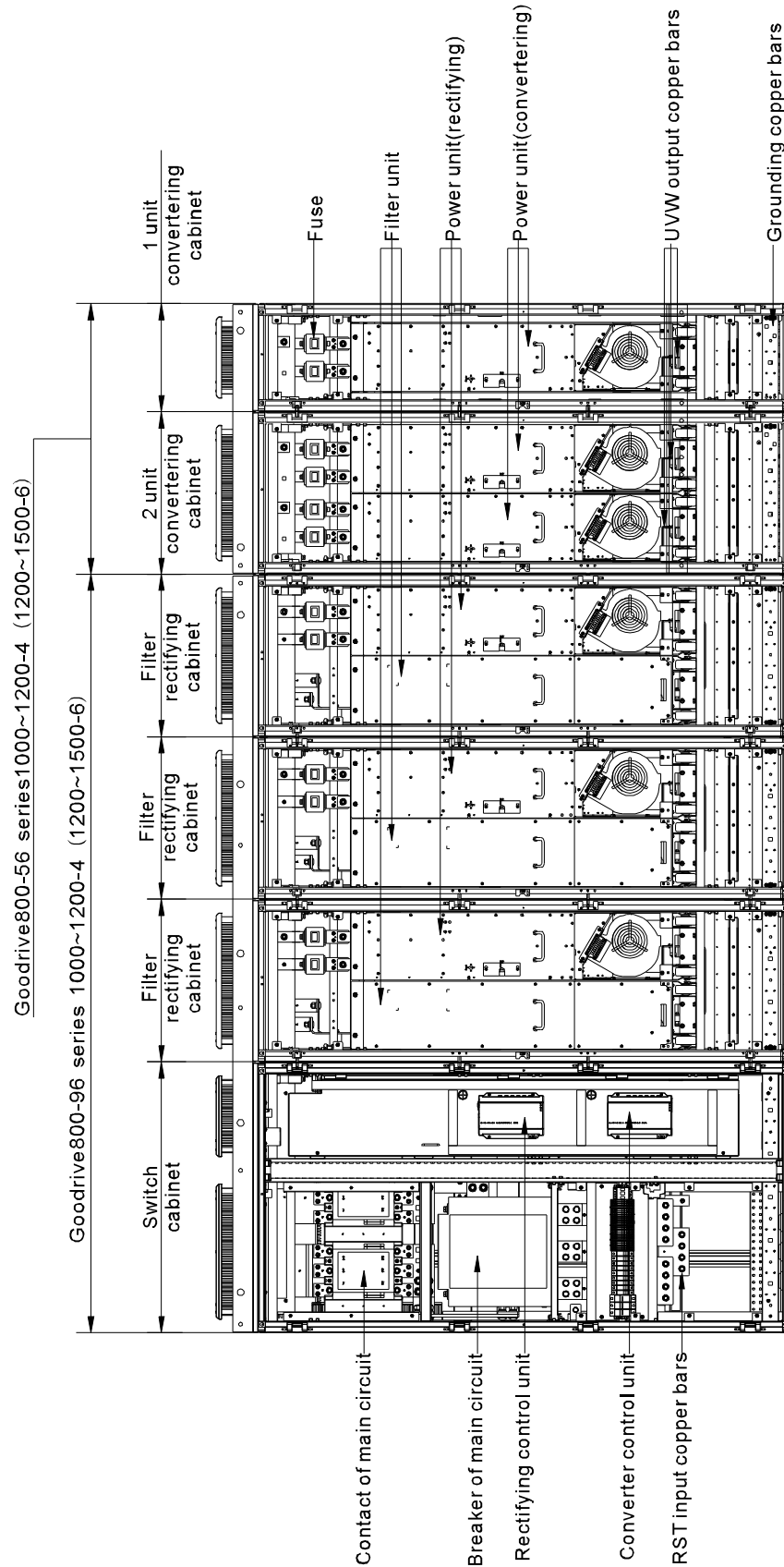

Components layout diagram of Goodrive800-26 series 1000~1200-4, 1000~1200-5 and 1200~1500-6

Components layout diagram of Goodrive800-96 series 1000~1200-4, 1000~1200-5 and 1200~1500-6 is the diagram without converting cabinet and converting control unit

Components layout diagram of Goodrive800-56 series 1000~1200-4, 1000~1200-5 and 1200~1500-6 is the diagram without filter rectifier cabinet and switch cabinet

6.2 Goodrive800 series control cabinets

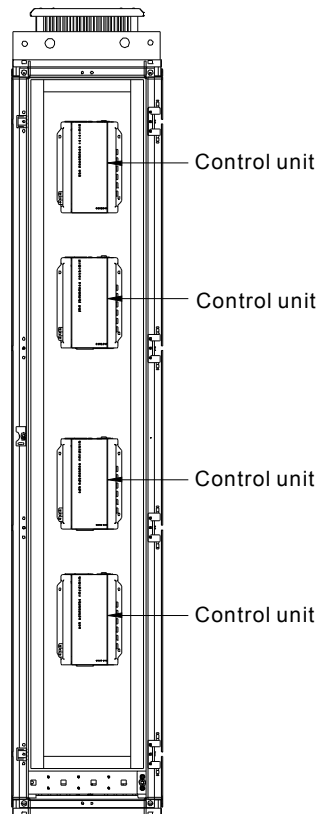

Goodrive800 series control cabinets are optional.

Chapter 7 Dimensions

7.1 Dimension of Goodrive800-26, Goodrive800-96 and Goodrive800-56

7.1.1 26S1 dimensions

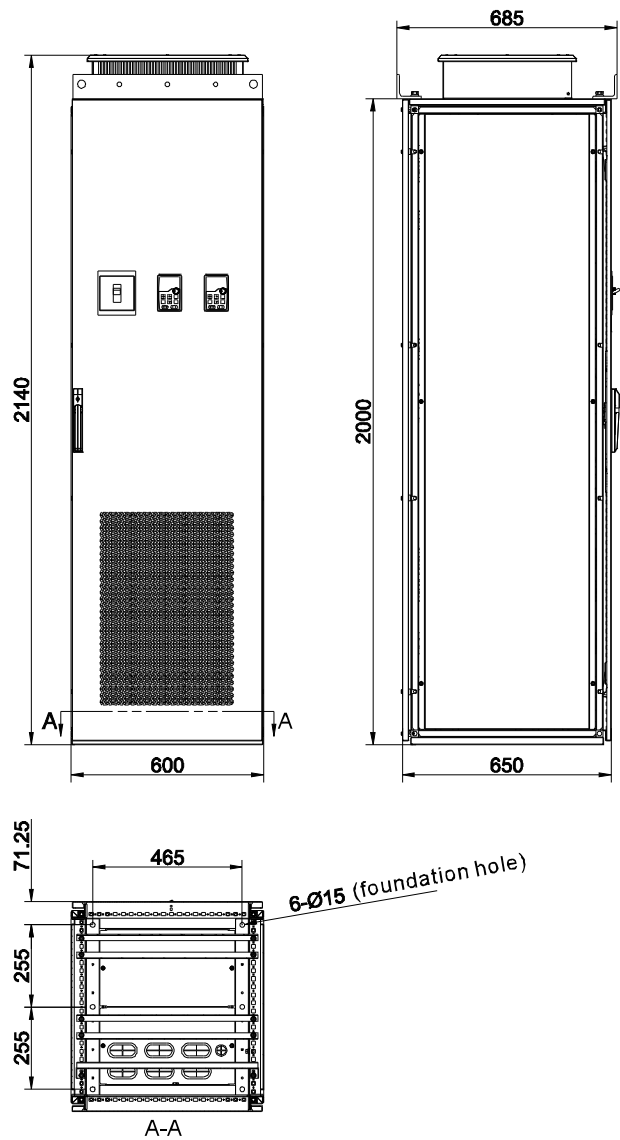

7.1.2 26S2 dimensions

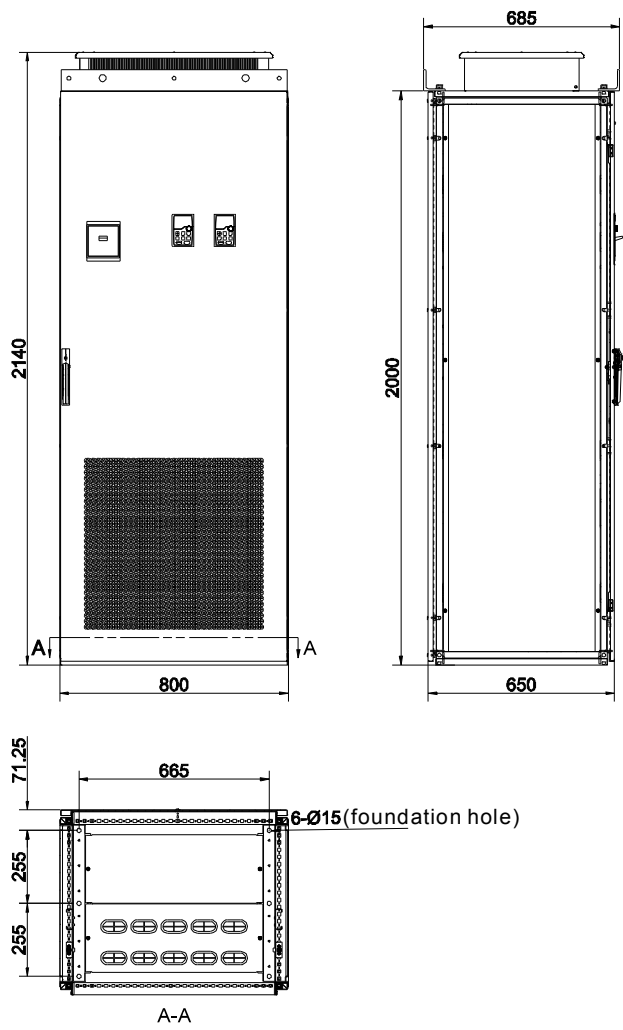

7.1.3 26S3 dimensions

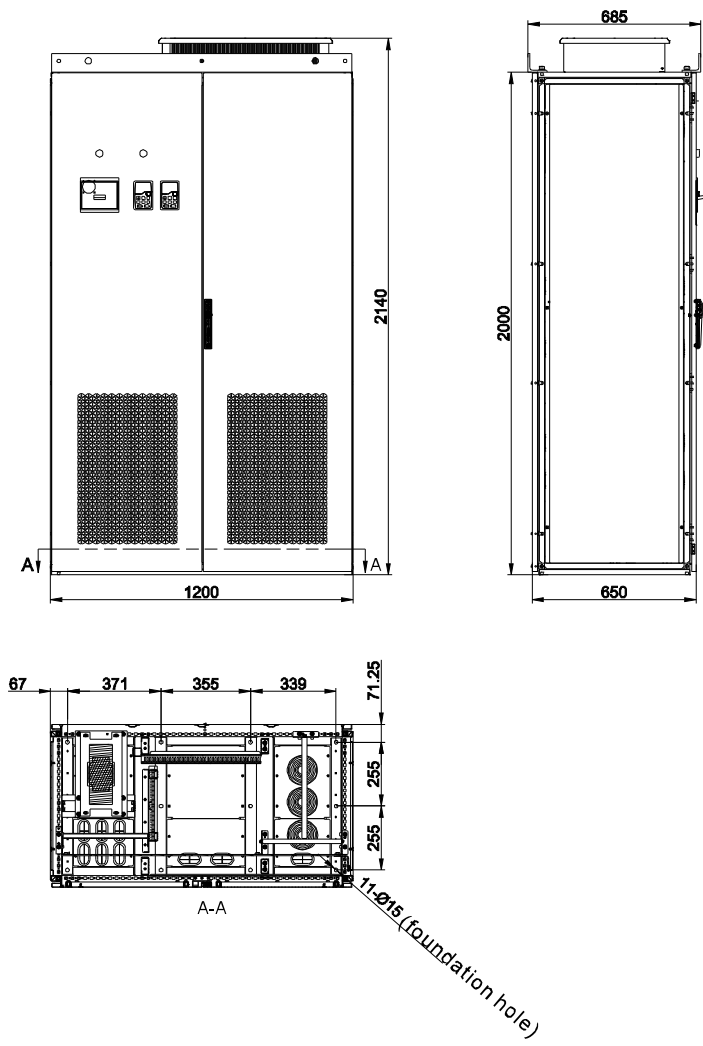

7.1.4 26M1, 56S1 and 96M1 dimensions

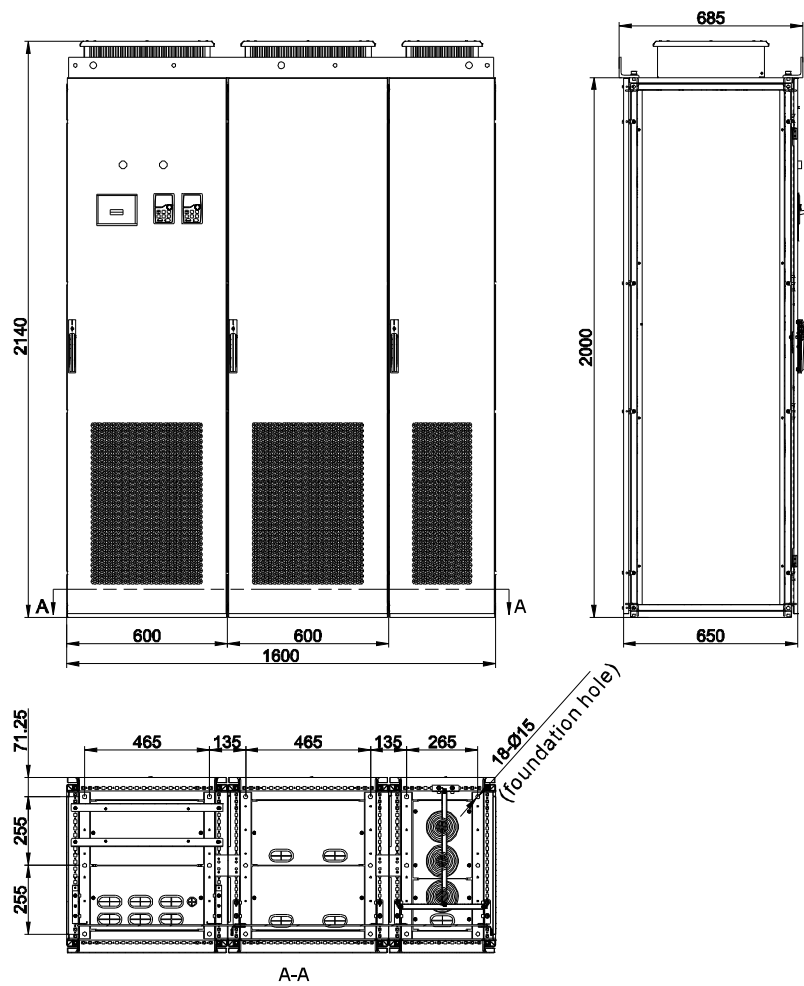

26M1, 56S1 and 96M1 dimensions

7.1.5 26M2, 56S2 and 96M2 dimensions

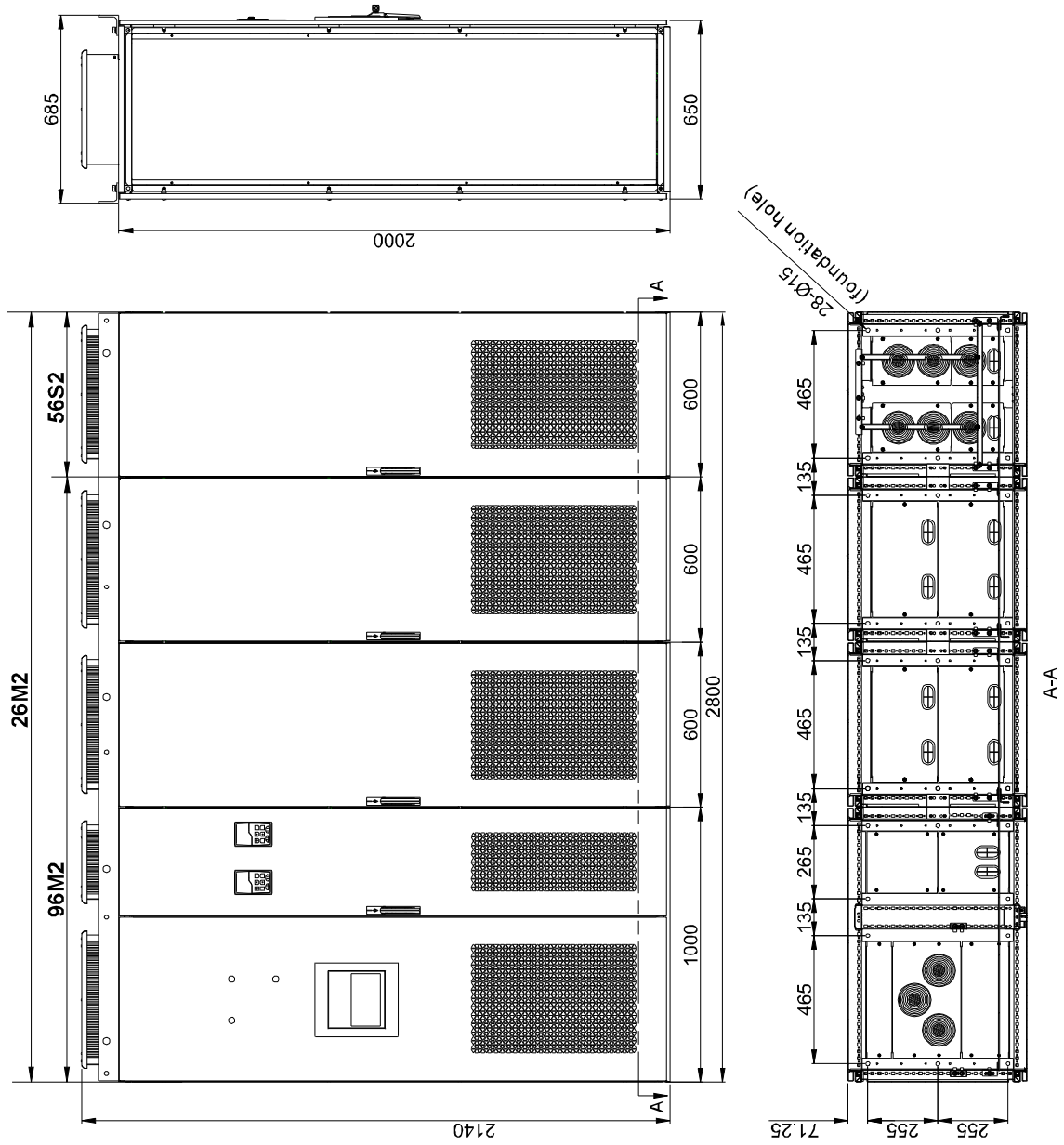

26M2, 56S2 and 96M2 dimensions

7.1.6 26M3, 56M1 and 96M3 dimensions

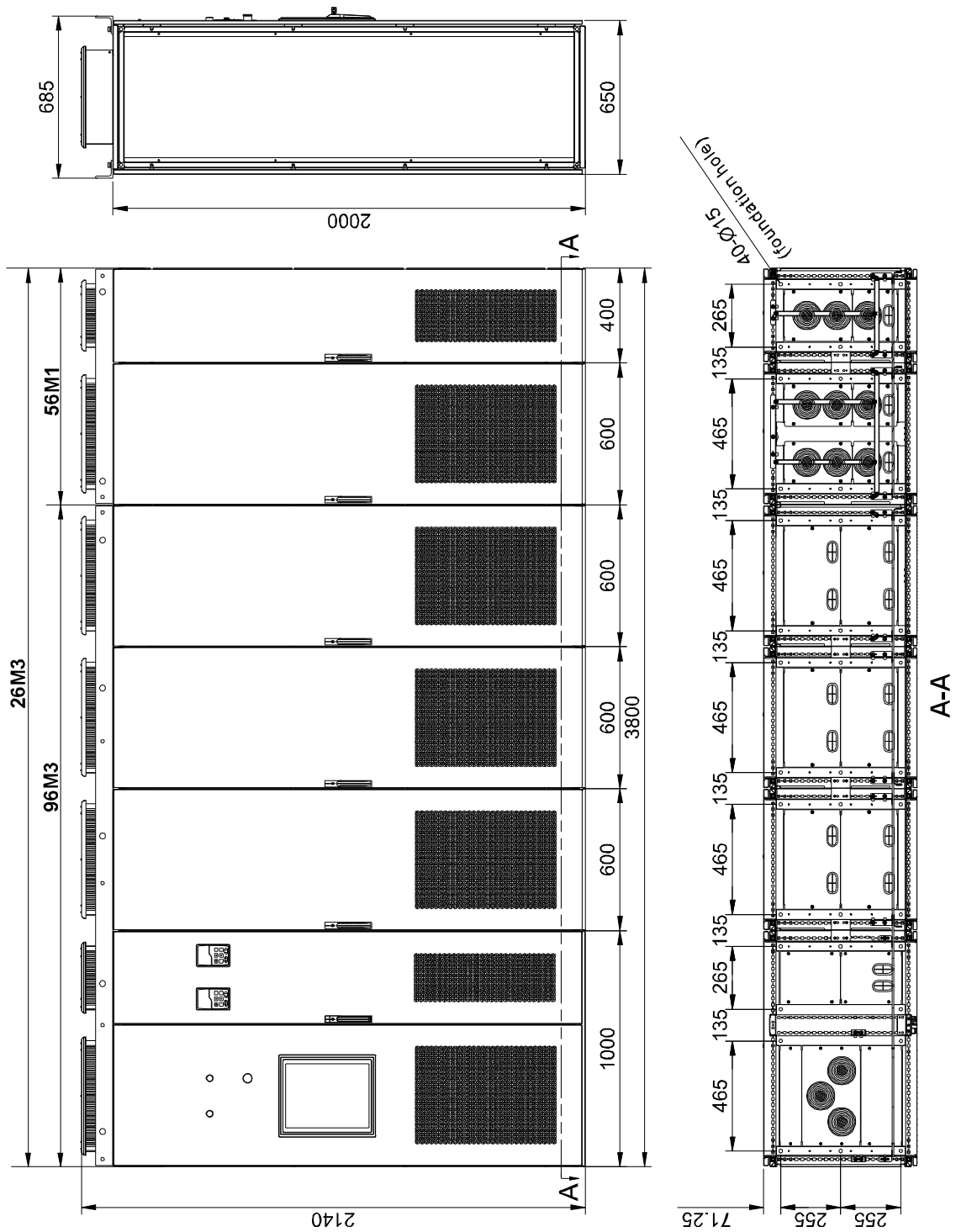

26M3, 56M1 and 96M3 dimensions

7.2 Goodrive800-11 series

7.2.1 Dimension of Goodrive800-11 series 11A1~11A6 for wall installation

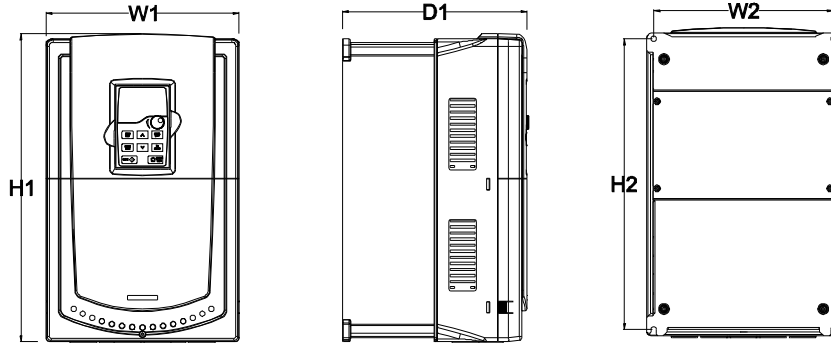

Dimension of wall installation for 11A1~11A4

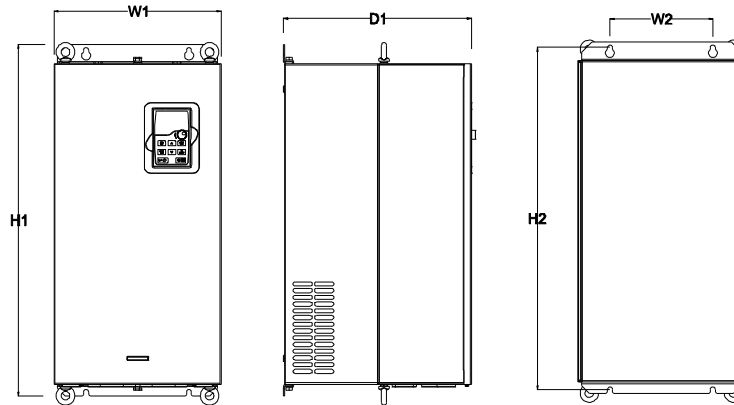

Dimension of wall installation for 11A5~11A6

Wall installation of 11A1~11A6

Structure	W1	W2	H1	H2	D1	Installation hole
11A1	146	131	263	243.5	181	6
11A2	170	151	331.5	303.5	216	6
11A3	230	210	342	311	216	6
11A4	255	237	407	384	245	7
11A5	270	130	555	540	325	7
11A6	325	200	680	661	365	9.5

7.2.2 Dimension of Goodrive800-11 series 11A1~11A6 for flange installation

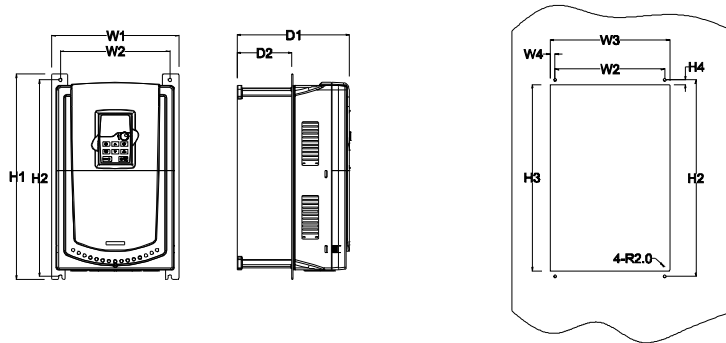

Flange installation of 11A1~11A4

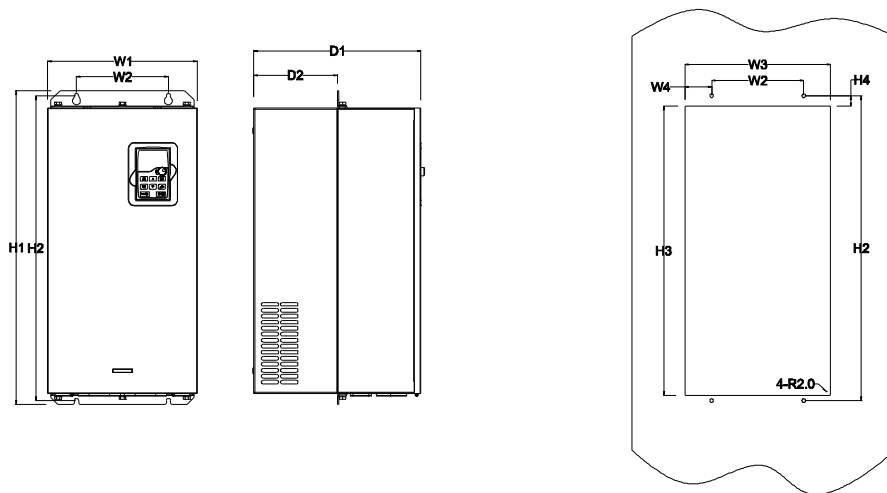

Flange installation of 11A5~11A6

Flange installation of 11A1~11A6

Structure	W1	W2	W3	W4	H1	H2	H3	H4	D1	D2	Installation hole
11A1	170	131	150	9.5	292	276	260	10	181	79.5	6
11A2	191	151	174	11.5	370	351	324	15	216.2	113	6
11A3	250	210	234	12	375	356	334	10	216	108	6
11A4	275	237	259	11	445	426	404	10	245	119	7
11A5	270	130	261	65.5	555	540	516	17	325	167	7
11A6	325	200	317	58.5	680	661	626	23	363	182	9.5

7.2.4 Dimension of Goodrive800-11 series 11A8

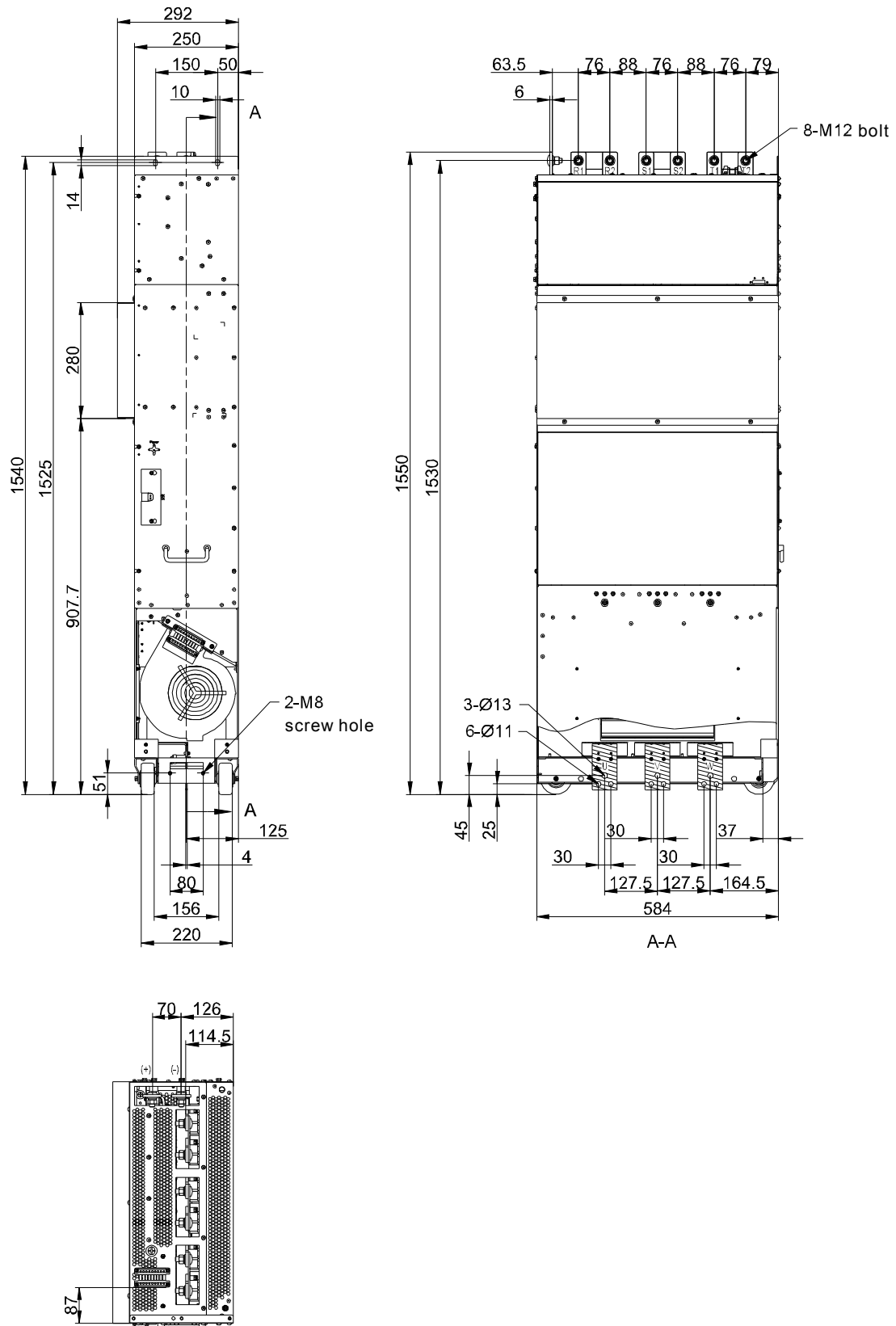

7.2.5 Dimension of Goodrive800-11 series 11B7~11B8

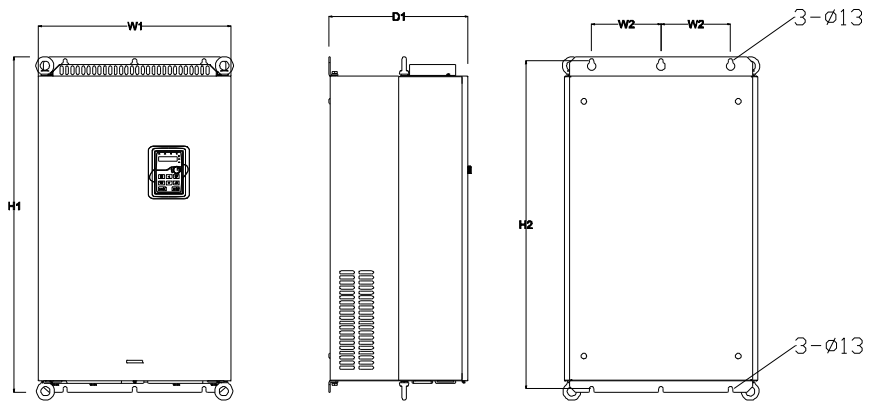

Wall installation of 11B7

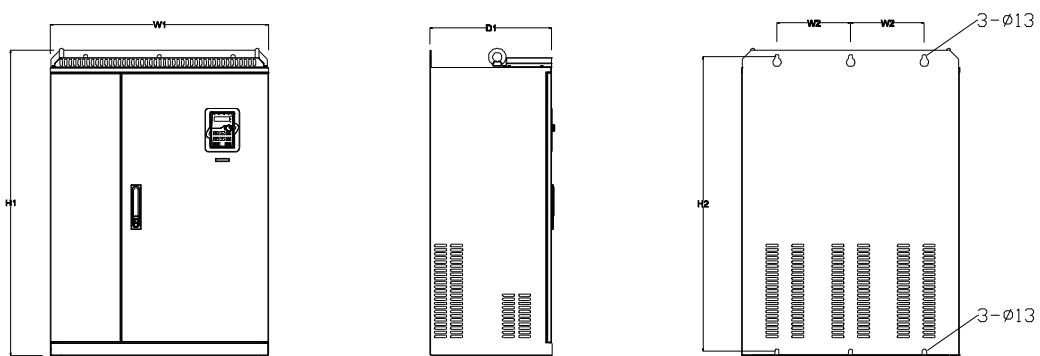

Wall installation of 11B8

Wall installation of 11B7~11B8 (unit: mm)

Structure	W1	W2	H1	H2	D1	Installation hole
11B7	500	180	870	850	360	11
11B8	680	230	960	926	380	13

7.2.6 Dimension of Goodrive800-11 series 11B7

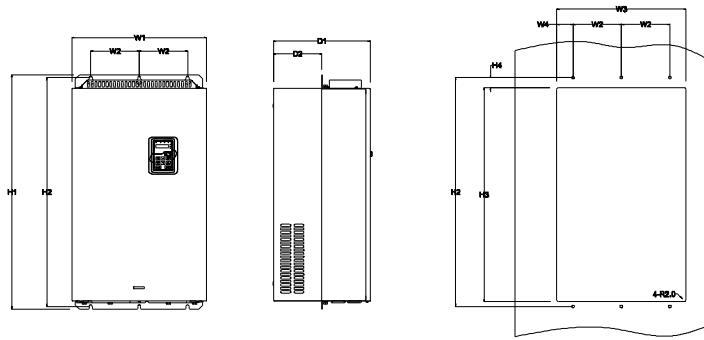

Flange installation of 11B7
Flange installation of 11B7 (unit: mm)

Structure	W1	W2	W3	W4	H1	H2	H3	H4	D1	D2	Installation hole
11B7	500	180	480	60	870	850	796	37	358	178.5	11

7.2.7 Dimension of Goodrive800-11 series 11B8~11B9

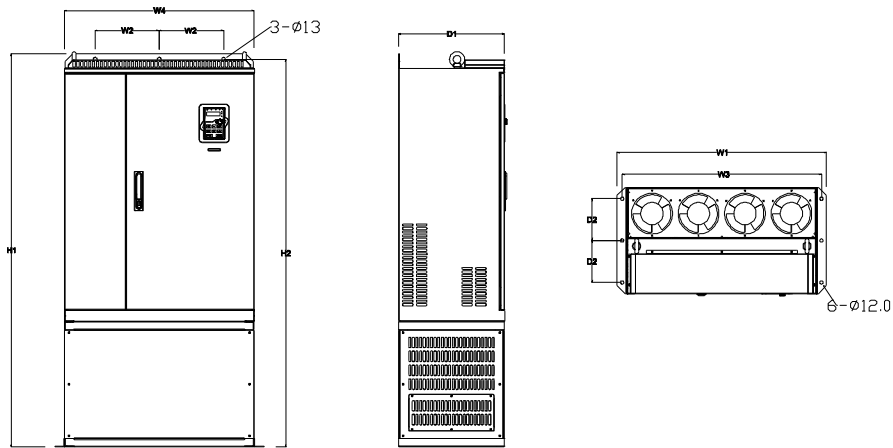

Floor installation of 11B8

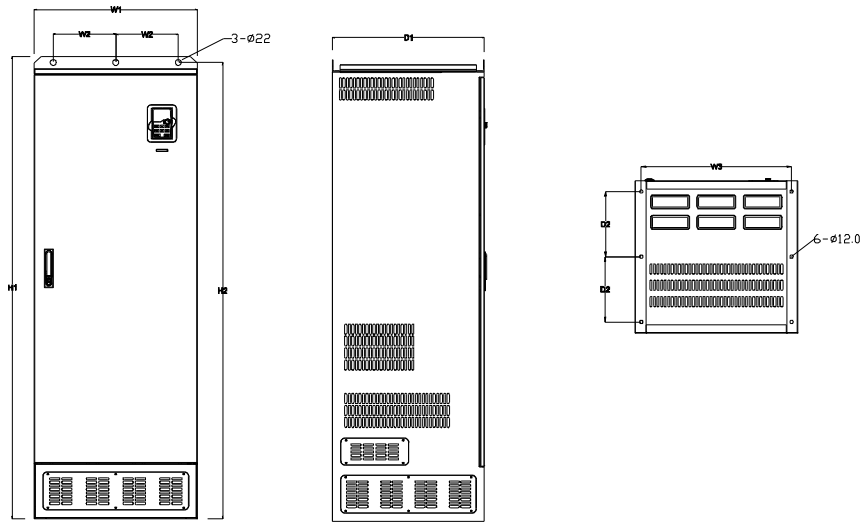

Floor installation of 11B9

Floor installation of 11B8~11B9

Structure	W1	W2	W3	W4	H1	H2	D1	D2	Installation hole
11B8	750	230	714	680	1410	1390	380	150	13\12
11B9	620	230	573	\	1700	1678	560	240	22\12

7.3 Goodrive800-51 series

7.3.1 Dimensions of Goodrive800-51 series 51A5

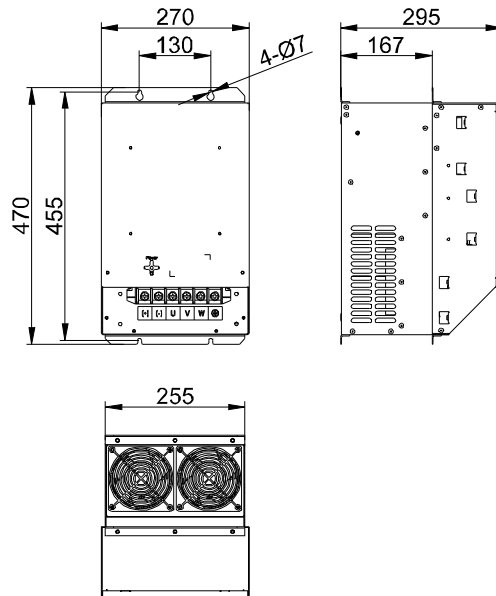

7.3.2 Dimensions of Goodrive800-51 series 51A6

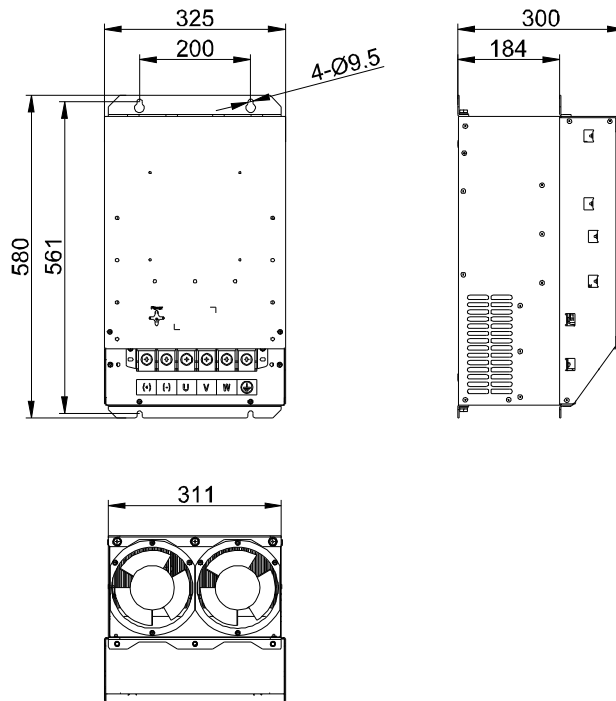

7.3.3 Dimensions of Goodrive800-51 series 51A7

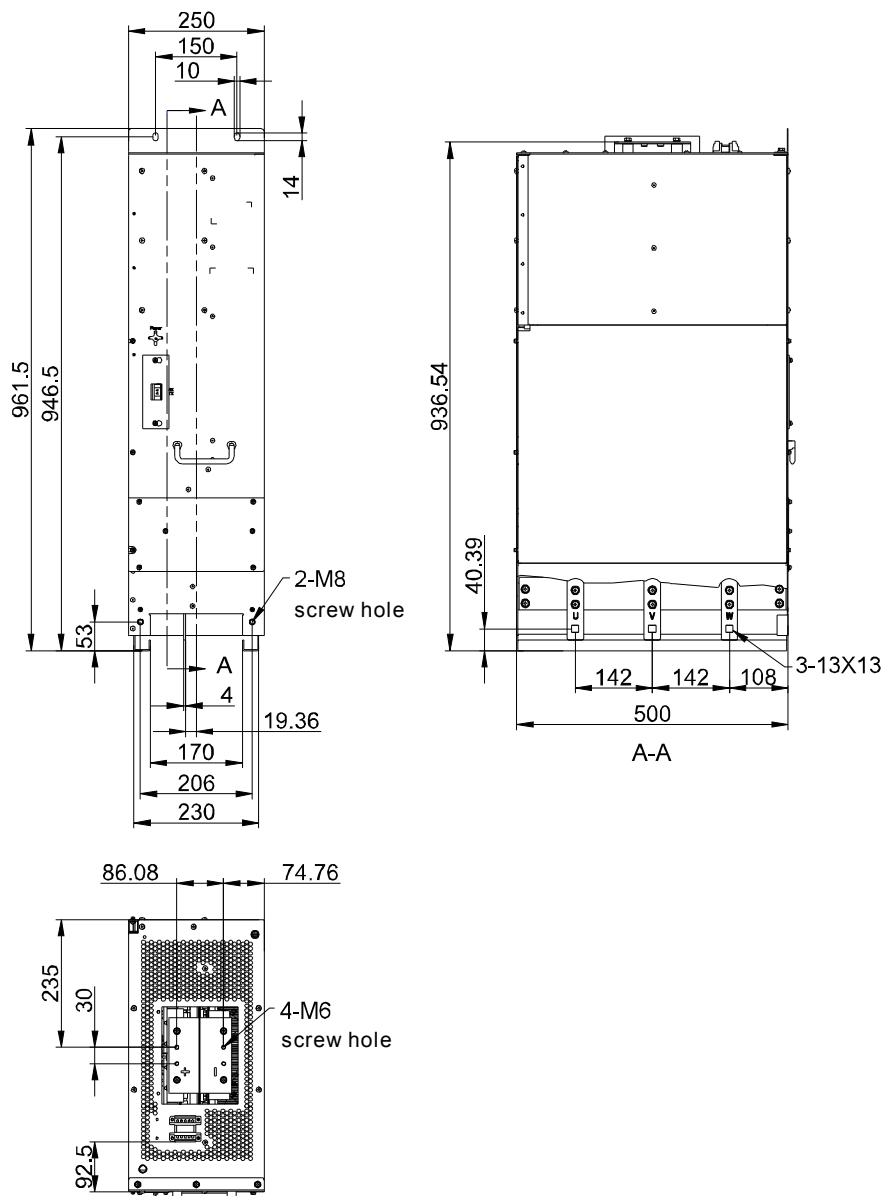

7.3.4 Dimensions of Goodrive800-51 series 51A8

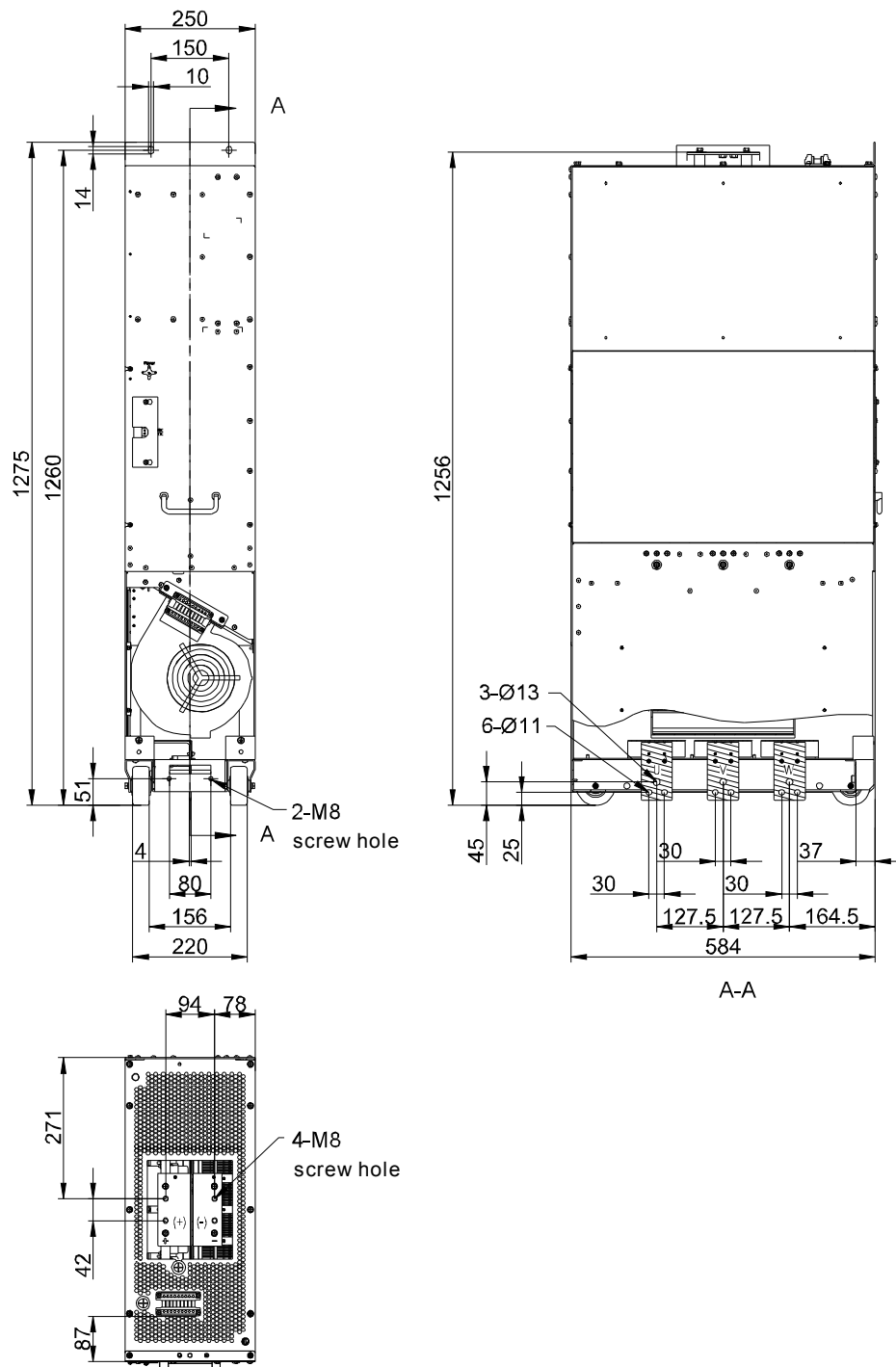

7.3.5 Dimensions of Goodrive800-51 series 51B7

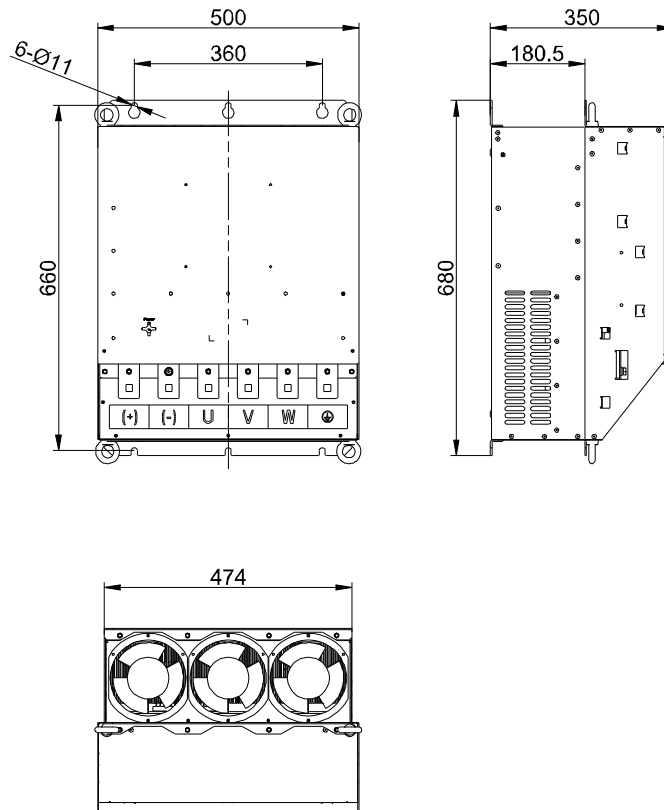

7.5 Goodrive800-01 series

7.5.1 Dimensions of Goodrive800-01 series 01A8

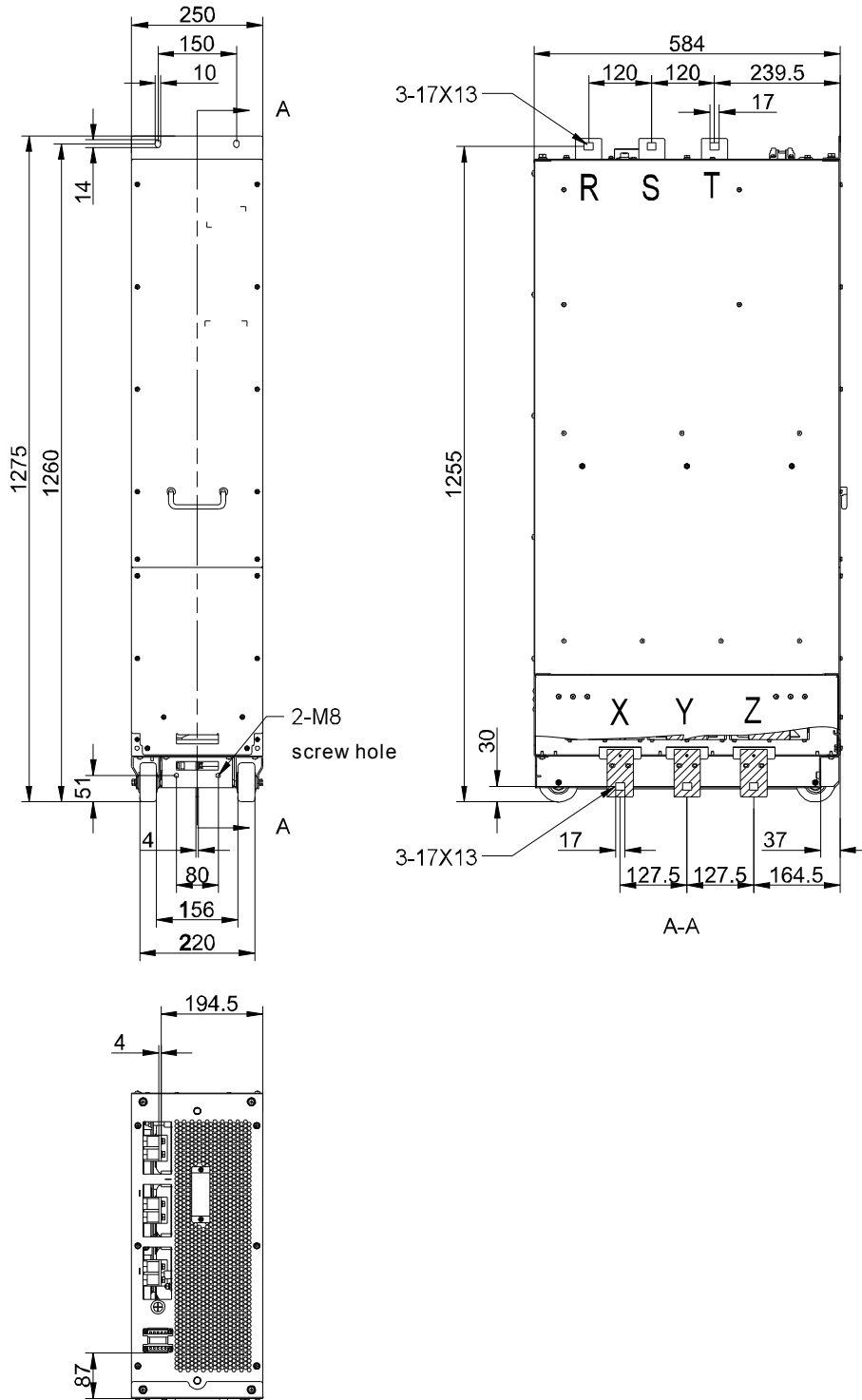

7.6 Goodrive800-02 series

7.6.1 Dimensions of Goodrive800-02 series 02A8

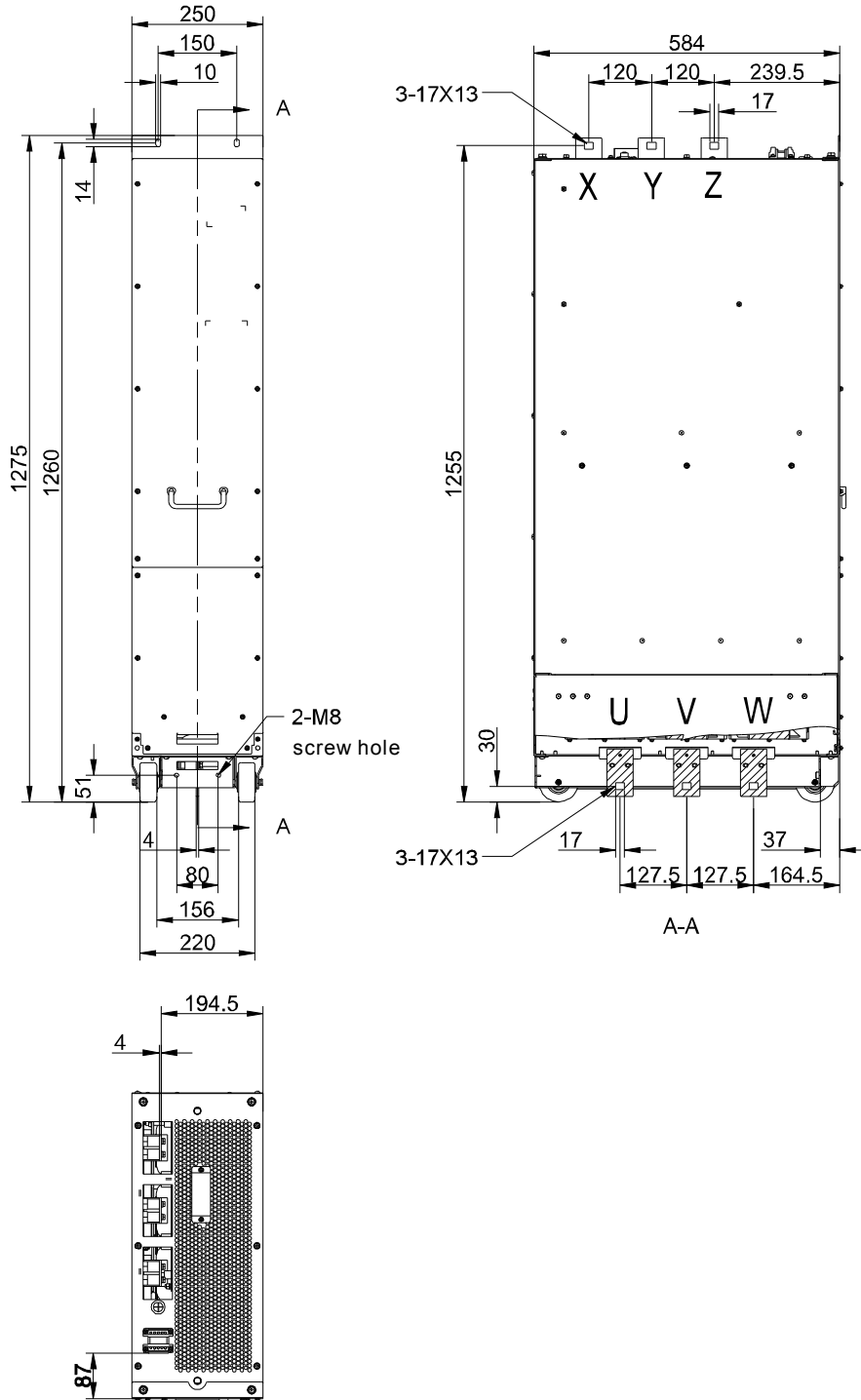

7.7 Goodrive800-03 series

7.7.1 Dimensions of Goodrive800-03 series 03A8

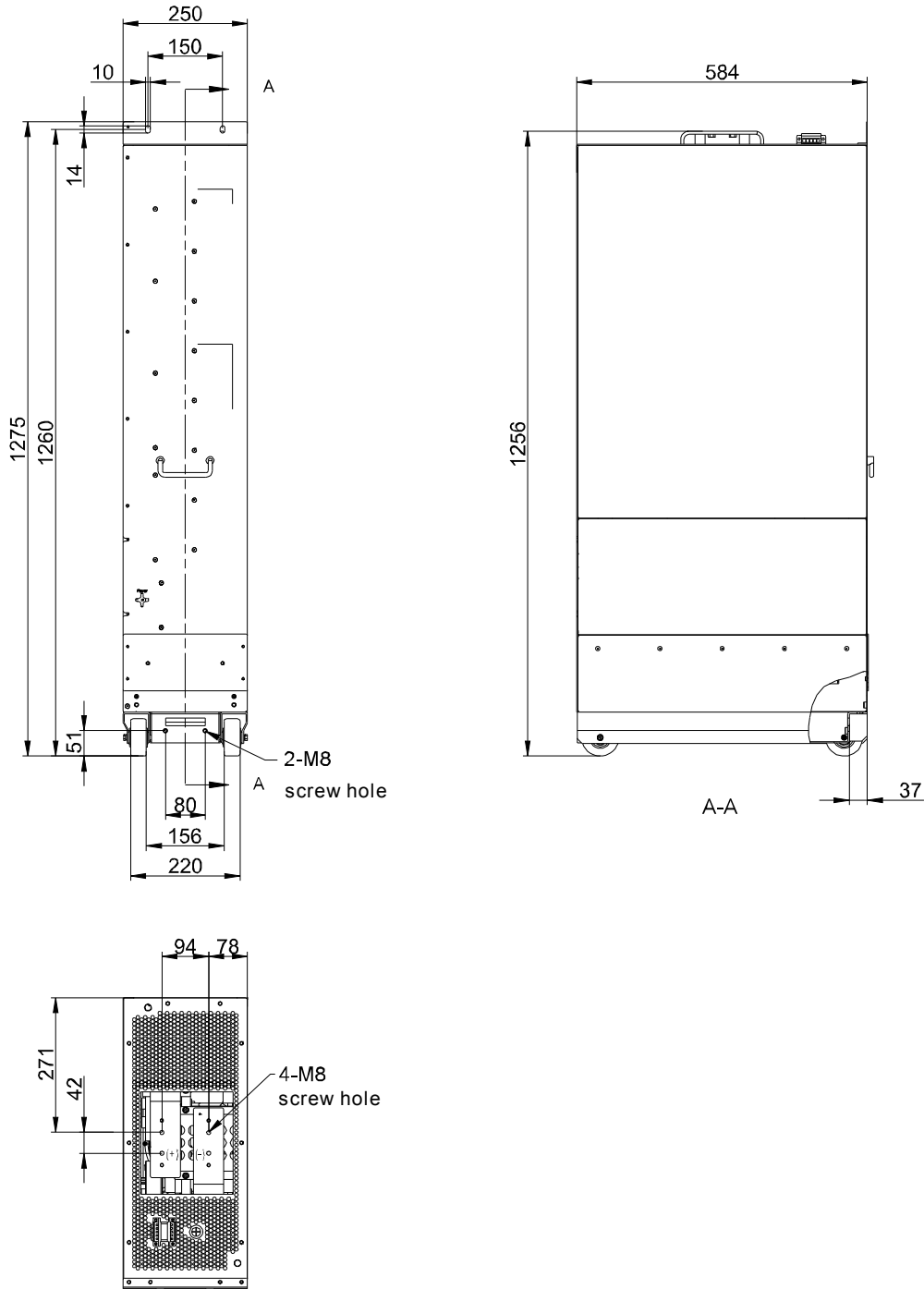

7.8 Goodrive800 series control cabinet

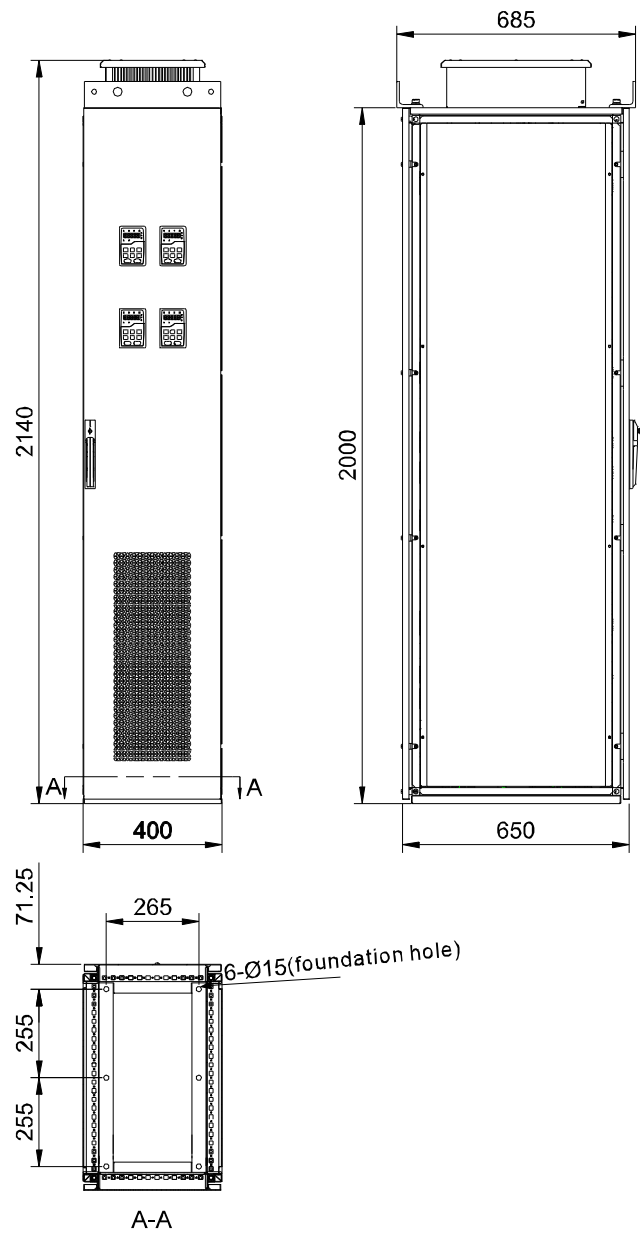

7.9 Goodrive800 series engineering IP20 standard cabinet

7.9.1 400mm standard cabinet

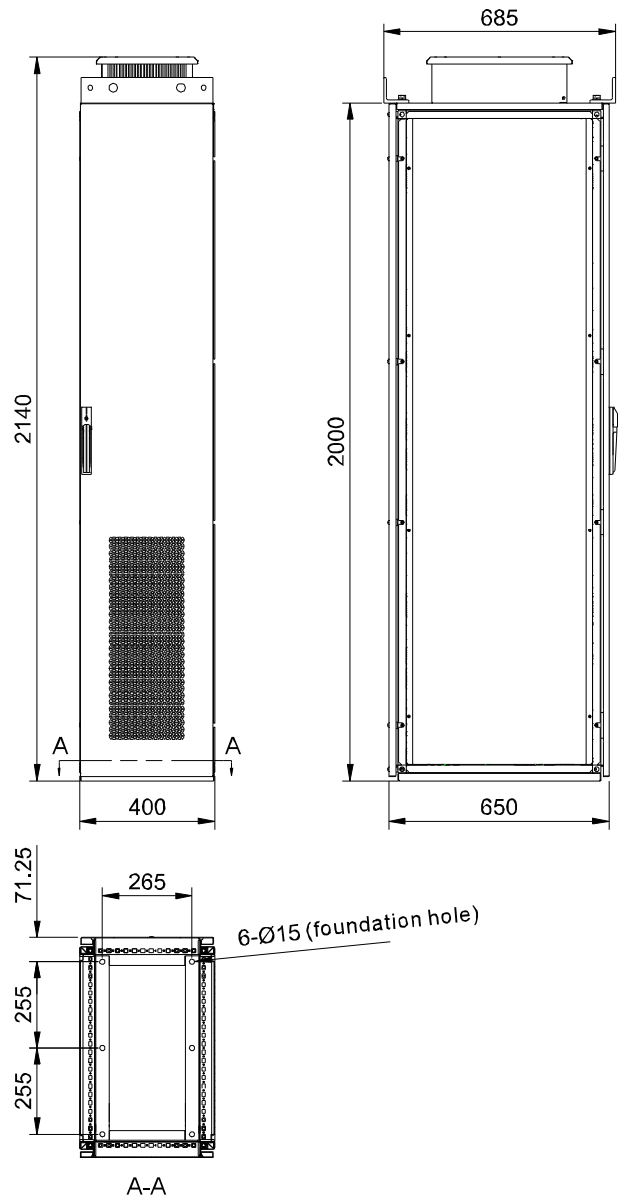

7.9.2 600mm standard cabinet

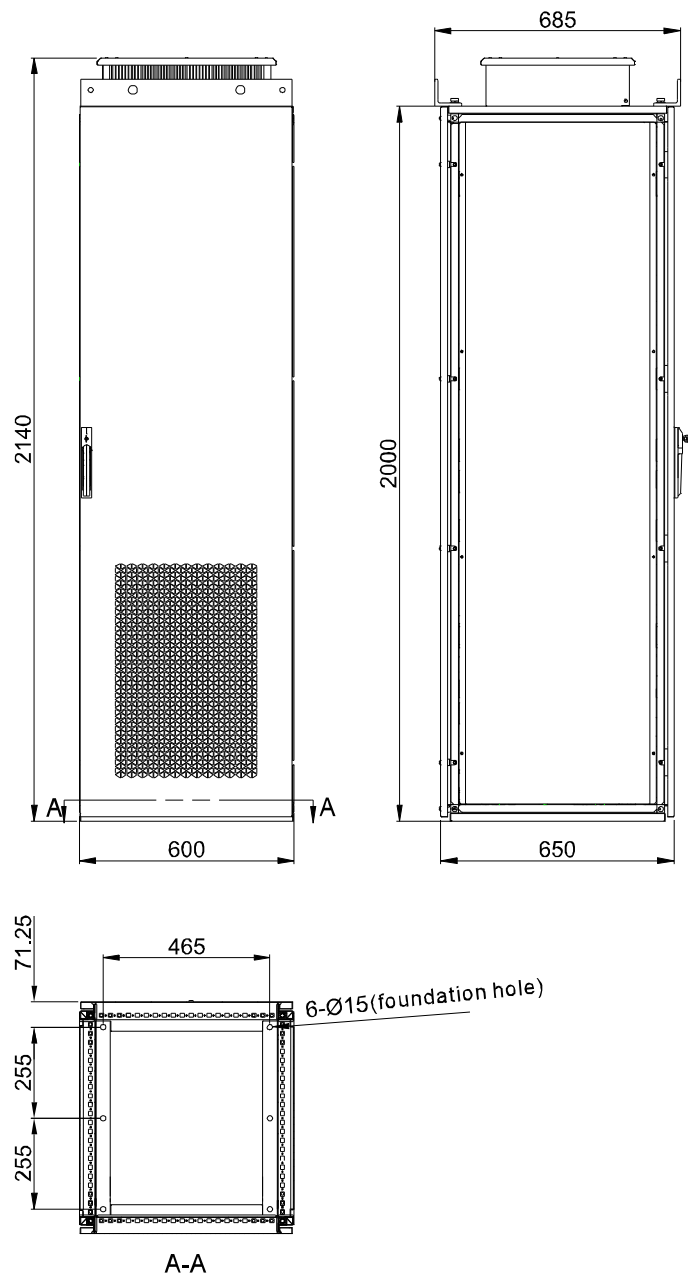

7.9.3 800mm standard cabinet

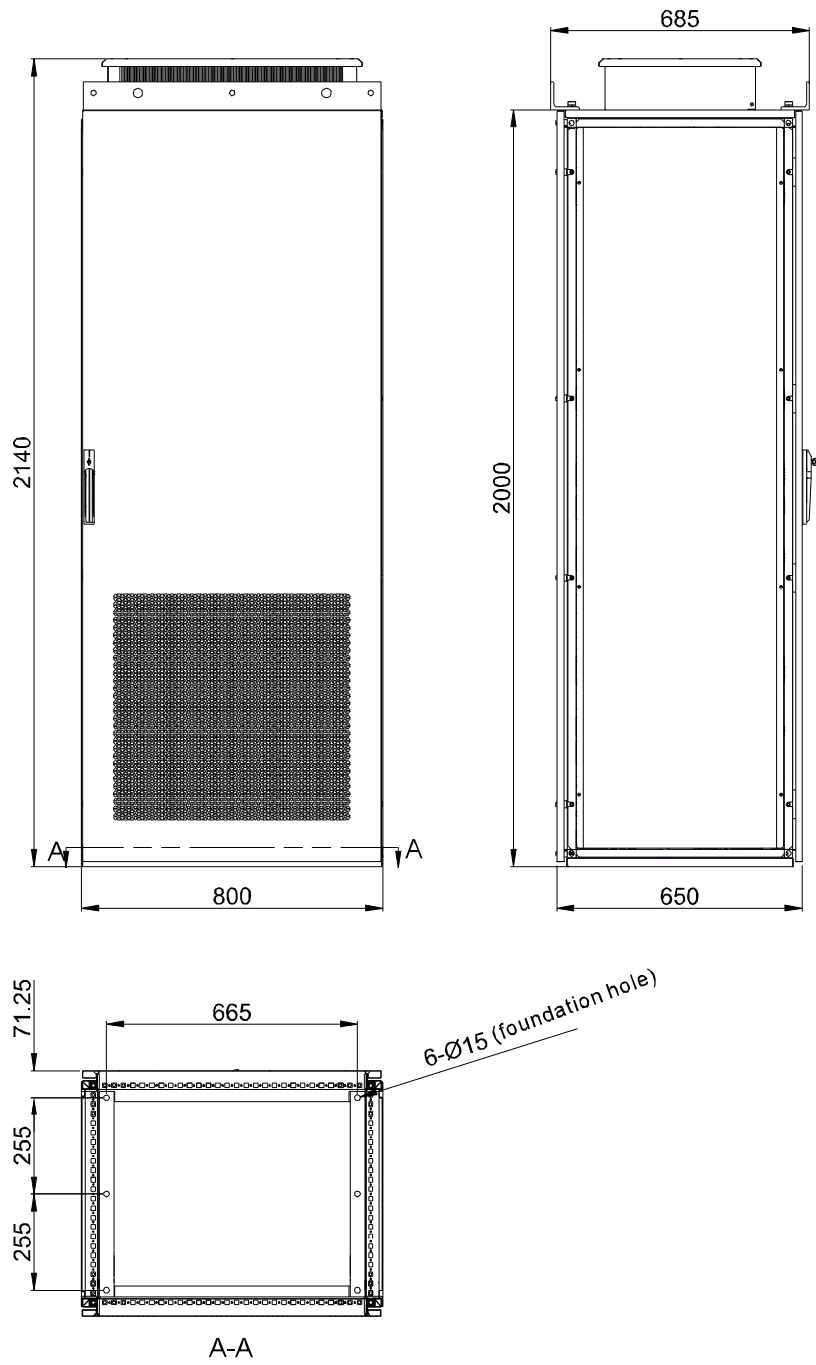

7.9.4 1000mm standard cabinet

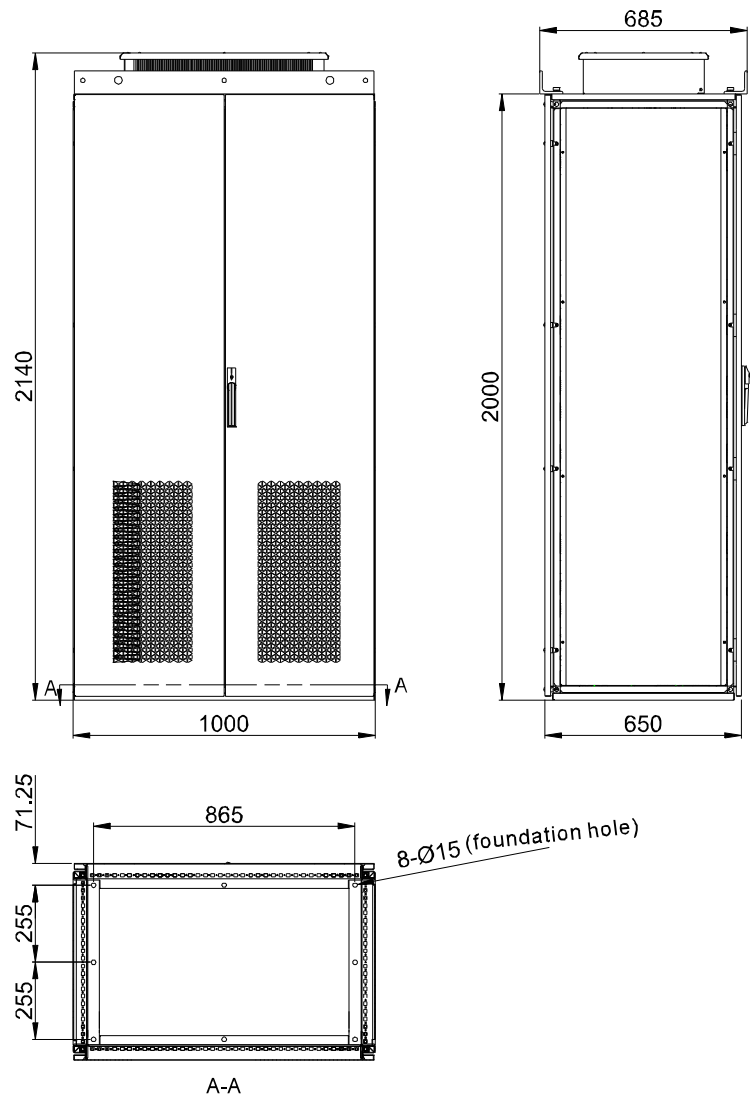

7.9.5 1200mm standard cabinet

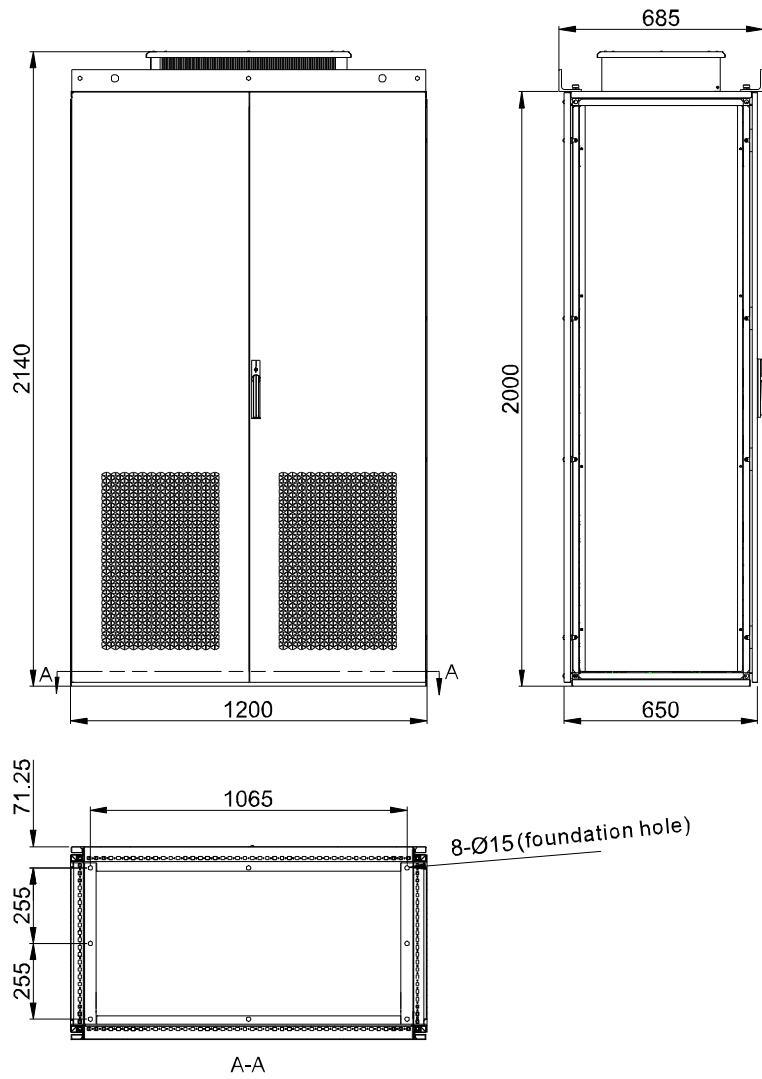

7.10 Goodrive800 series control unit

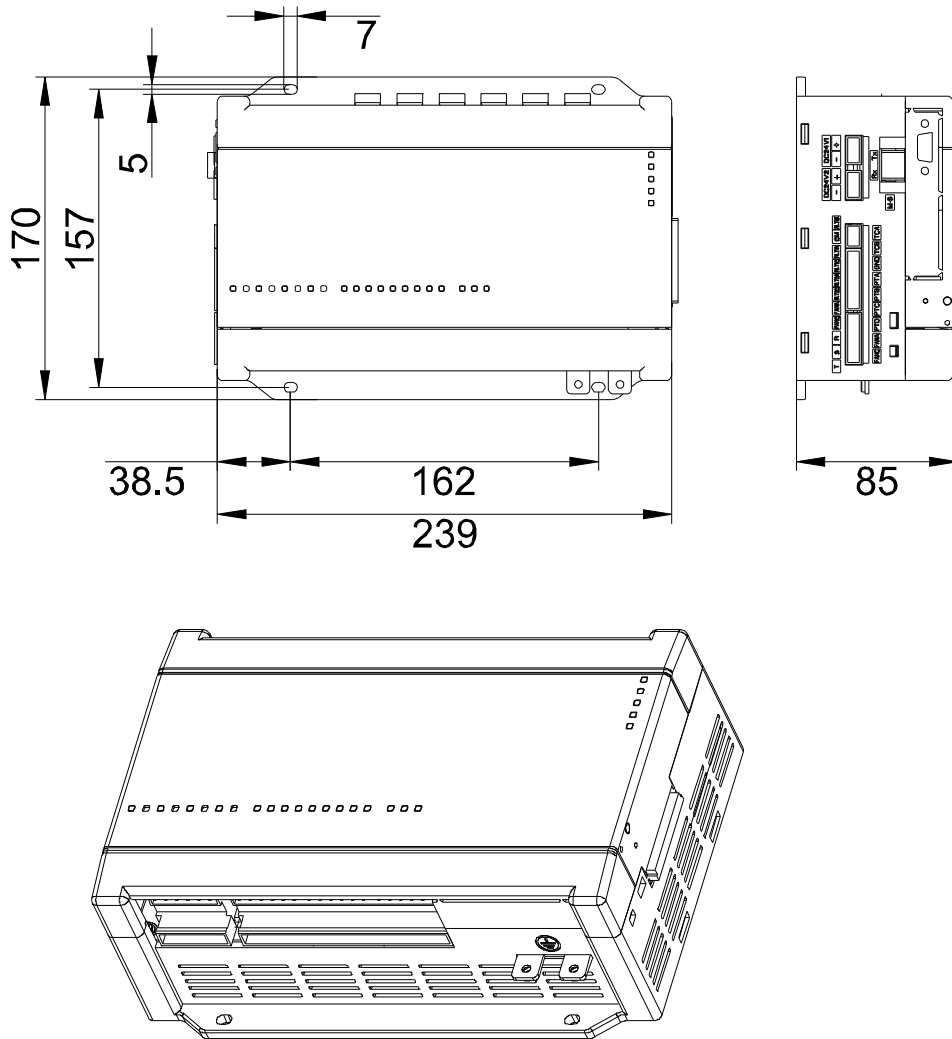

7.11 Goodrive800 series keypad

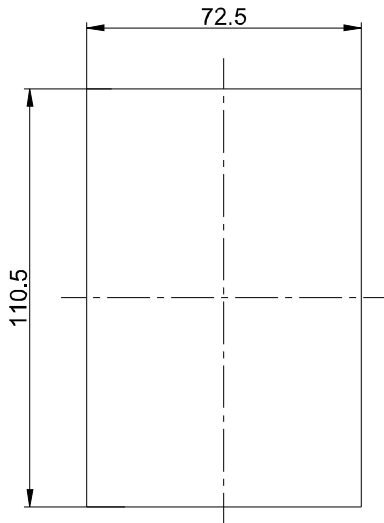
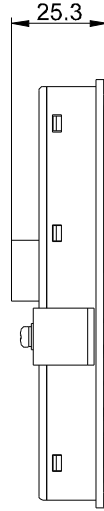
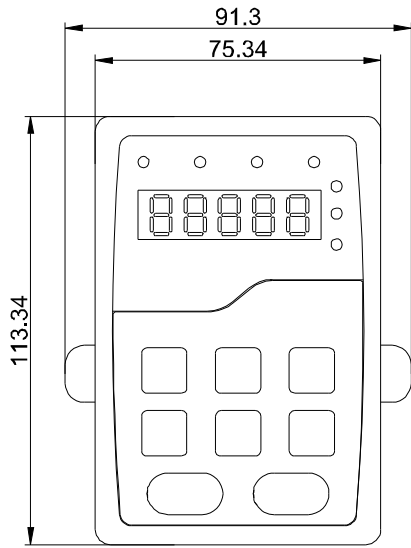

Hole size

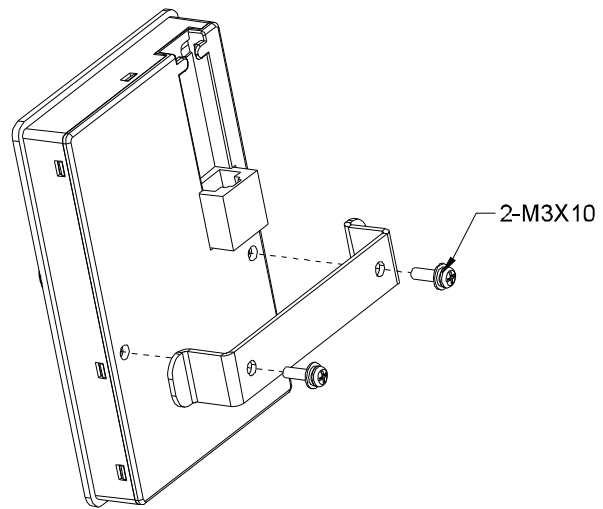

Chapter 8 Peripheral options

8.1 Optional card

8.1.1 IO extension card (reserved)

8.1.2 Communication extension card

8.1.2.1 Outline drawing

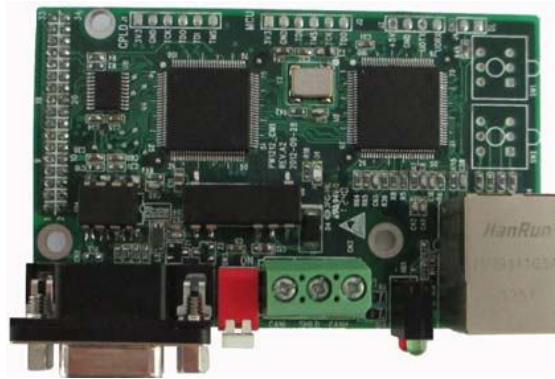

ETHERNET+ CANopen communication card

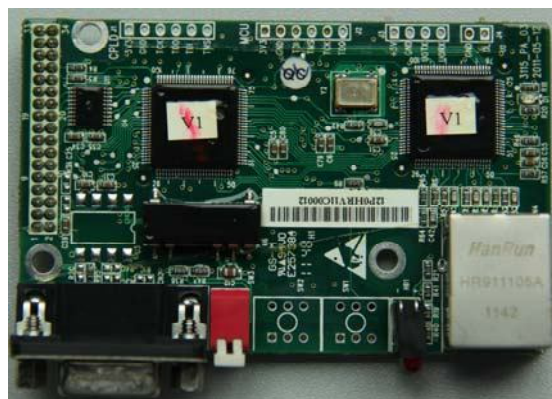

ETHERNET +PROFIBUS communication card

8.1.2.2 Product name

EC-TX 1 03

① ② ③ ④

No.	Description	Details
①	Product type	EC: Extension card
②	Card type	TX: Communication card
③	Technology version	Odds such as 1,3,5,7 stands for the 1 st , 2 nd , 3 rd ,4 th technical version
④	Difference	03: PROFIBUS+ETHERNET communications card 04: ETHERNET+CANopen communications card

8.1.2.3 Structure of EC-TX series communication card

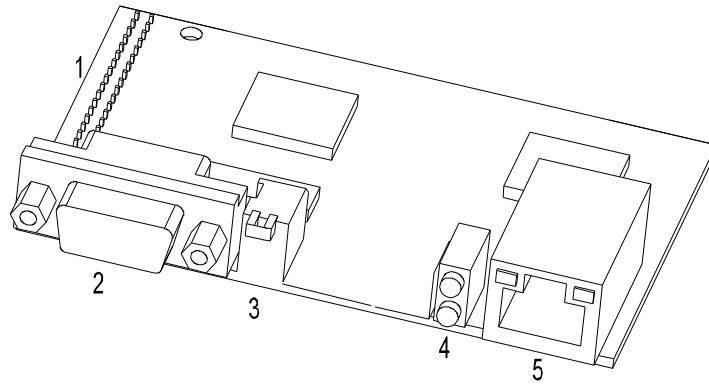

Outline drawing of EC-TX series communication card

Serial No.	Name	Description																																																
1	Interface with the control board	Connected to the control board																																																
2	Bus communication interface	<p>Shielded twisted-pair copper wire is widely used for PROFIBUS and CAN transmission.</p> <p>Pin arrangements when PROFIBUS protocol is available:</p> <table border="1"> <thead> <tr> <th>Connector pins</th> <th>Description</th> <th>Connector pins</th> <th>Description</th> </tr> </thead> <tbody> <tr> <td>1</td> <td>-</td> <td>2</td> <td>-</td> </tr> <tr> <td>3</td> <td>B-Line</td> <td>4</td> <td>RTS</td> </tr> <tr> <td>5</td> <td>GND_BUS</td> <td>6</td> <td>+5V BUS</td> </tr> <tr> <td>7</td> <td>-</td> <td>8</td> <td>A-Line</td> </tr> <tr> <td>9</td> <td>-</td> <td>Housing</td> <td>SHLD</td> </tr> </tbody> </table> <p>Pin arrangements when CAN protocol is available:</p> <table border="1"> <thead> <tr> <th>Connector pins</th> <th>Description</th> <th>Connector pins</th> <th>Description</th> </tr> </thead> <tbody> <tr> <td>1</td> <td>-</td> <td>2</td> <td>CANL</td> </tr> <tr> <td>3</td> <td>GNDBUS</td> <td>4</td> <td>-</td> </tr> <tr> <td>5</td> <td>SHLD</td> <td>6</td> <td>GNDBUS</td> </tr> <tr> <td>7</td> <td>CANH</td> <td>8</td> <td>-</td> </tr> <tr> <td>9</td> <td>-</td> <td>Housing</td> <td>SHLD</td> </tr> </tbody> </table>	Connector pins	Description	Connector pins	Description	1	-	2	-	3	B-Line	4	RTS	5	GND_BUS	6	+5V BUS	7	-	8	A-Line	9	-	Housing	SHLD	Connector pins	Description	Connector pins	Description	1	-	2	CANL	3	GNDBUS	4	-	5	SHLD	6	GNDBUS	7	CANH	8	-	9	-	Housing	SHLD
Connector pins	Description	Connector pins	Description																																															
1	-	2	-																																															
3	B-Line	4	RTS																																															
5	GND_BUS	6	+5V BUS																																															
7	-	8	A-Line																																															
9	-	Housing	SHLD																																															
Connector pins	Description	Connector pins	Description																																															
1	-	2	CANL																																															
3	GNDBUS	4	-																																															
5	SHLD	6	GNDBUS																																															
7	CANH	8	-																																															
9	-	Housing	SHLD																																															
3	Bus terminator	<p>For EC-TX103 and valid in PROFIBUS communication</p> <p>There is a bus terminal in each heading and ending to avoid error during operation. The bus terminals can avoid the signal feedback from the bus cables. If the module is the first or last one in the internet, the bus terminal should be set as ON. Please disconnect EC-TX terminals when the PROFIBUS D-sub connector with internal</p>																																																

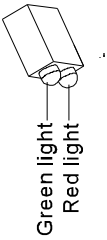
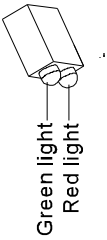
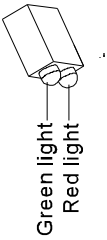
Serial No.	Name	Description									
		terminals is in use.									
5	LEDs	Display faults									
		<table border="1"> <thead> <tr> <th>LED No.</th> <th>Name</th> <th>Color</th> <th>Function</th> </tr> </thead> <tbody> <tr> <td rowspan="2">  </td> <td>Online</td> <td>Green</td> <td>ON-module online and data can be exchanged. OFF-module is not in "online" state.</td> </tr> <tr> <td>Offline/ Fault</td> <td>Red</td> <td>ON-module offline and data can not be exchanged. OFF-module is not in "offline" state. Flicker frequency 1Hz-configuration error: The length of user parameter data sets is different from that of network configuration process during module initialization process. Flicker frequency 2Hz-user parameter data error: The length or content of user parameter data sets is different from that of network configuration process during module initialization process. Flicker frequency 4Hz-communication ASIC initialization error.</td> </tr> </tbody> </table>	LED No.	Name	Color	Function		Online	Green	ON-module online and data can be exchanged. OFF-module is not in "online" state.	Offline/ Fault
LED No.	Name	Color	Function								
	Online	Green	ON-module online and data can be exchanged. OFF-module is not in "online" state.								
	Offline/ Fault	Red	ON-module offline and data can not be exchanged. OFF-module is not in "offline" state. Flicker frequency 1Hz-configuration error: The length of user parameter data sets is different from that of network configuration process during module initialization process. Flicker frequency 2Hz-user parameter data error: The length or content of user parameter data sets is different from that of network configuration process during module initialization process. Flicker frequency 4Hz-communication ASIC initialization error.								
6	ETHERNET interface	Connected to ETHERNET									

8.1.2.4 Structure of EC-TX105 series communication card

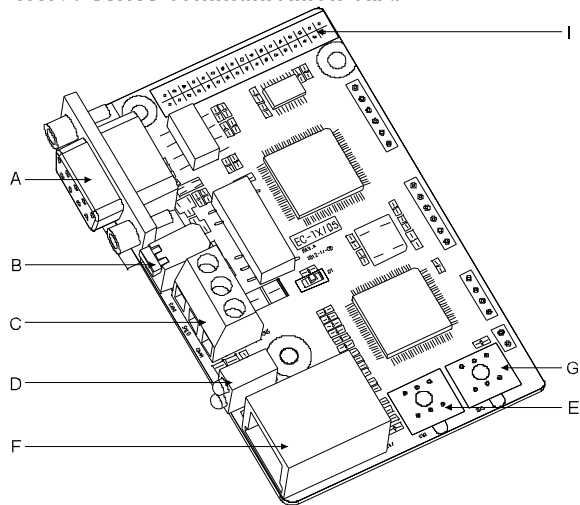

No.	Name	Description						
A	CANopen communication interface (DB9 female)	Two interfaces: DB9 female(A) and a 3pin terminal (C)						
		<table border="1"> <thead> <tr> <th>CANopen communication interface (DB9 female)</th> <th>Pin</th> <th>Function</th> <th>Description</th> </tr> </thead> <tbody> <tr> <td></td> <td>1</td> <td>-</td> <td></td> </tr> </tbody> </table>	CANopen communication interface (DB9 female)	Pin	Function	Description		1
CANopen communication interface (DB9 female)	Pin	Function	Description					
	1	-						

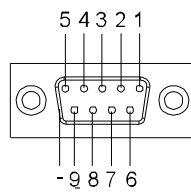
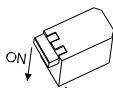
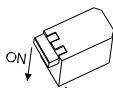
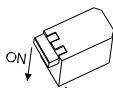
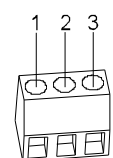
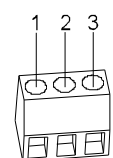
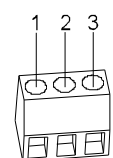
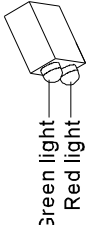
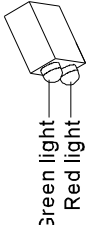
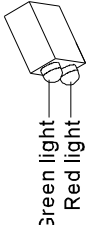
No.	Name	Description																													
		 <table border="1"> <tr> <td>4</td> <td>-</td> <td></td> </tr> <tr> <td>5</td> <td>CAN_SHLD</td> <td>CANopen bus shielding</td> </tr> <tr> <td>6</td> <td>-</td> <td></td> </tr> <tr> <td>7</td> <td>CAN_H</td> <td>CANopen bus high level signal</td> </tr> <tr> <td>8</td> <td>-</td> <td></td> </tr> <tr> <td>9</td> <td>-</td> <td></td> </tr> <tr> <td>-</td> <td>CAN_SHLD</td> <td>CANopen bus shielding</td> </tr> </table>	4	-		5	CAN_SHLD	CANopen bus shielding	6	-		7	CAN_H	CANopen bus high level signal	8	-		9	-		-	CAN_SHLD	CANopen bus shielding								
4	-																														
5	CAN_SHLD	CANopen bus shielding																													
6	-																														
7	CAN_H	CANopen bus high level signal																													
8	-																														
9	-																														
-	CAN_SHLD	CANopen bus shielding																													
B	CANopen terminal switch	<p>The functions are as below:</p> <table border="1"> <thead> <tr> <th>Terminal switch</th> <th>Position</th> <th>Function</th> <th>Description</th> </tr> </thead> <tbody> <tr> <td rowspan="2"></td> <td>Up</td> <td>OFF</td> <td>No terminal resistor for CAN_H and CAN_L</td> </tr> <tr> <td>Down</td> <td>ON</td> <td>120 ohm</td> </tr> </tbody> </table>	Terminal switch	Position	Function	Description		Up	OFF	No terminal resistor for CAN_H and CAN_L	Down	ON	120 ohm																		
Terminal switch	Position	Function	Description																												
	Up	OFF	No terminal resistor for CAN_H and CAN_L																												
	Down	ON	120 ohm																												
C	CANopen communication terminals (3pin)	<p>C Two interfaces: DB9 female(A) and a 3pin terminal (C)</p> <table border="1"> <thead> <tr> <th>3pin terminal</th> <th>Pin</th> <th>Function</th> <th>Description</th> </tr> </thead> <tbody> <tr> <td rowspan="3"></td> <td>1</td> <td>CAN_L</td> <td>CANopen bus low level signal</td> </tr> <tr> <td>2</td> <td>CAN_SHLD</td> <td>CANopen bus shielding</td> </tr> <tr> <td>3</td> <td>CAN_H</td> <td>CANopen bus high level signal</td> </tr> </tbody> </table>	3pin terminal	Pin	Function	Description		1	CAN_L	CANopen bus low level signal	2	CAN_SHLD	CANopen bus shielding	3	CAN_H	CANopen bus high level signal															
3pin terminal	Pin	Function	Description																												
	1	CAN_L	CANopen bus low level signal																												
	2	CAN_SHLD	CANopen bus shielding																												
	3	CAN_H	CANopen bus high level signal																												
D	CANopen LEDs	<p>Display faults</p> <table border="1"> <thead> <tr> <th>LED No.</th> <th>Name</th> <th>Color</th> <th>Function</th> <th>State</th> <th>Description</th> </tr> </thead> <tbody> <tr> <td rowspan="4"></td> <td rowspan="4">RUN LEDs</td> <td rowspan="4">Green</td> <td>Blink once and off</td> <td>Stop</td> <td>In stop state</td> </tr> <tr> <td>Blink</td> <td>Pre-operation</td> <td>In pre-operation state</td> </tr> <tr> <td>On</td> <td>Operation</td> <td>In operation state</td> </tr> <tr> <td>Off</td> <td>Fault</td> <td>Check the communication card and the power connection</td> </tr> <tr> <td rowspan="2">ERROE LEDs</td> <td rowspan="2">Red</td> <td>Off</td> <td>No fault</td> <td>In running state</td> </tr> <tr> <td>On</td> <td>Bus off or inverter fault</td> <td>Bus off or inverter fault</td> </tr> </tbody> </table>	LED No.	Name	Color	Function	State	Description		RUN LEDs	Green	Blink once and off	Stop	In stop state	Blink	Pre-operation	In pre-operation state	On	Operation	In operation state	Off	Fault	Check the communication card and the power connection	ERROE LEDs	Red	Off	No fault	In running state	On	Bus off or inverter fault	Bus off or inverter fault
LED No.	Name	Color	Function	State	Description																										
	RUN LEDs	Green	Blink once and off	Stop	In stop state																										
			Blink	Pre-operation	In pre-operation state																										
			On	Operation	In operation state																										
			Off	Fault	Check the communication card and the power connection																										
ERROE LEDs	Red	Off	No fault	In running state																											
		On	Bus off or inverter fault	Bus off or inverter fault																											

No.	Name	Description					
					Blink	Initialization error	Wrong address setting
E	ETHERNET interface	Connect to ETHERNET communication					
F	CANopen high address knob (spare)	Note: The two knobs are not installed. And the communication address is set by the function codes.					
G	CANopen low address knob (spare)						
H	LEDs of the communication power supply						
I	Control board port	Connect to the control board port					

8.1.2.5 Installation

1. Insert the communication card into the designated position on the control board:

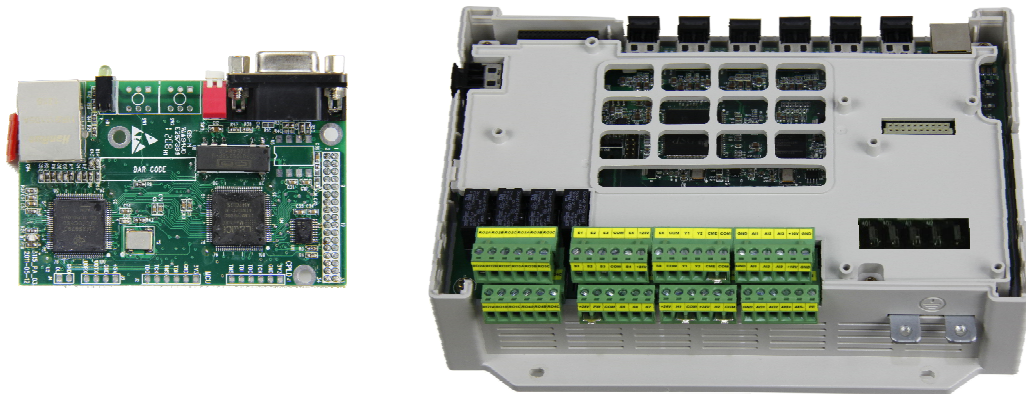

- 2 Fix it on the board:



Note:

Disconnect all power supplied before installation and wait at least 3 minutes until the capacitor is discharged enough. Disconnect the dangerous voltage of the unit input/output from external control circuit.

Some electronic components on the communication card are sensitive to electrostatic discharge. Do not touch the board with hand and do wear grounding wrist strap if inevitable operation is needed to the board.

8.1.3 PG extension card

8.1.3.1 Incremental encoder PG card

(1) Model and specification

EC-PG 1 01 - 05

① ② ③ ④ ⑤

No.	Sign	Example
①	Product type	EC-extension card
②	Card type	PG: P/G card
③	Technical versions	Odds such as 1, 3 and 5 stands for the 1 st , 2 nd and 3 rd generation.
④	Code	01: Incremental encoder PG card 02: Cosine encoder PG card 03: UVW encoder PG card 04: The resolver PG card
⑤	Power supply	05: 5V 12: 12~15V 24: 24V

Technical specifications

Model	EC-PG101-12	EC-PG101-24
Output power supply	Support 11.75V~16V output, the factory value is 12V±5%, Max. Output current is 350mA.	24V±5% output, Max. Output current is 300mA
Input signal	Support the differential open-collector push-pull encoder A, B, Z signal input, the response speed of 0 ~ 100kHz	Support the differential open-collector push-pull encoder A, B, Z signal input, the response speed of 0 ~ 100kHz
Output signal	Output frequency: 0~80kHz Output: Differential output, push-pull output, open collector output, frequency division output Range: 1~256 Output impedance :70Ω	Output frequency: 0~80kHz Output: Differential output, push-pull output, open collector output, frequency division output Range: 1~256 Output impedance :70Ω

(2) Installation and dimension of incremental PG card

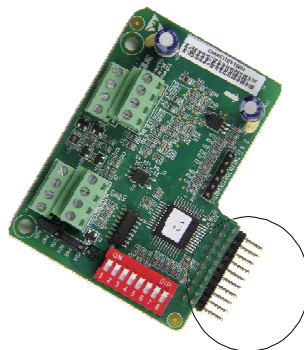

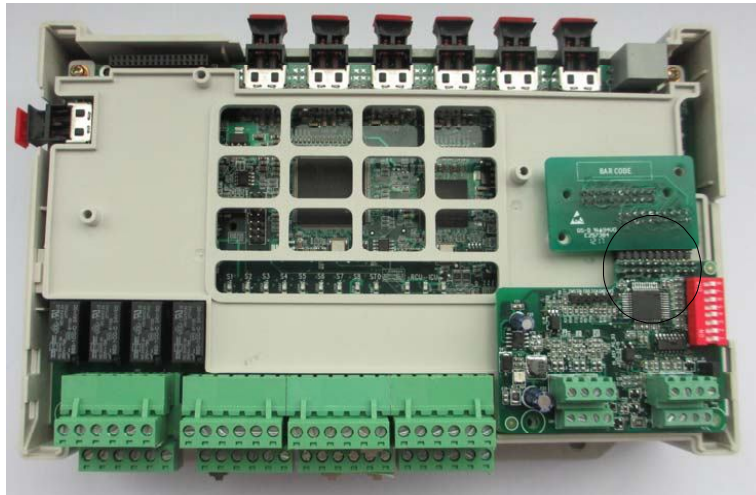

Note: CN3 lower pins are valid when use incremental encoder PG card.

(3) Function

It is necessary to select PG card in PG vector control. The function of the PG card includes processing circuits for two channels of orthogonal coder signals, being capable of receiving signals from differential output, open-circuit collector output and push-pull output encoders, coder power supply. In addition, it can output in frequency-division the inputted encoder signals (output are two channels of orthogonal signals). The user can select by J1 and J2 according to actual utilization.

(4) Description of terminals and DIP switch

There are 2 2*4P wiring terminal on the PG card.

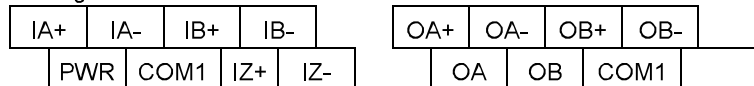

Of which, PWR and COM1 are working voltage output for the encoder; IA+, IA-, IB+, IB-, IZ+ and IZ- are signal input terminals for the encoder; OA+, OA-, OB+ and OB- are output terminals for frequency-division signals; OA, OB and COM1 are the output terminal of frequency - division push-pull signal and open collector signal; the user can grounded the PG by themselves.

The frequency division factor is determined by the DIP switch on the card. The DIP switch consists of 8 bits. When the binary digits are displayed by DIP switch pluses 1, the relative value is frequency division factor. The bit marked as “1” on the DIP switch is the lower binary bit, while “8” is the higher binary bit. When the DIP switch is switched to ON, the bit is valid, indicating “1” ; otherwise, it indicates “0” .

Decimal digit	Binary digit	Frequency division factor
0	00000000	1
1	00000001	2
2	00000010	3
...
m	...	m+1
255	11111111	256

(5) Wiring diagram

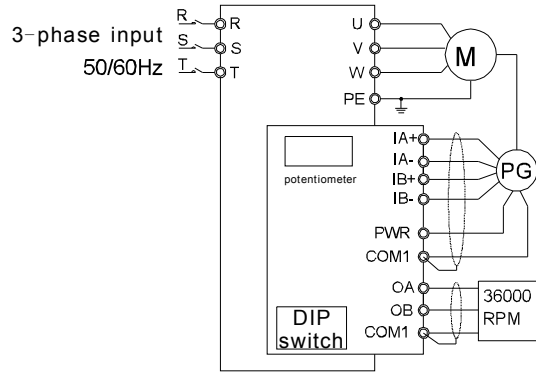

(6) Wiring notes

1. The signal line of PG card should be separated from the power line. Parallel wiring is forbidden.
2. Select shielded cables as the signal lines of PG card to prevent coder signals from disturbance.
3. The shielding layer of shielded cable of PG card should be grounded (such as terminal PE of the inverter), and furthermore, only one end is grounded, to prevent signal from disturbance.
4. If the frequency-division output of PG card is connected to the user power supply, the voltage should be less than 24V; otherwise, the PG card may be damaged.
5. The user can adjust 12~15V incremental encoder PG card potentiometer based on actual demand. Operate gently when setting the output voltage and rotating.

(7) Input application connection

① Wiring diagram of differential output encoder

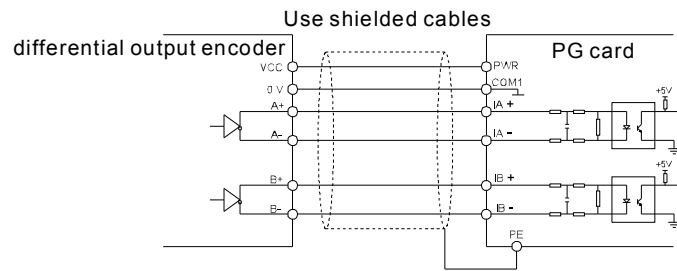

② Wiring diagram of open collector output encoder

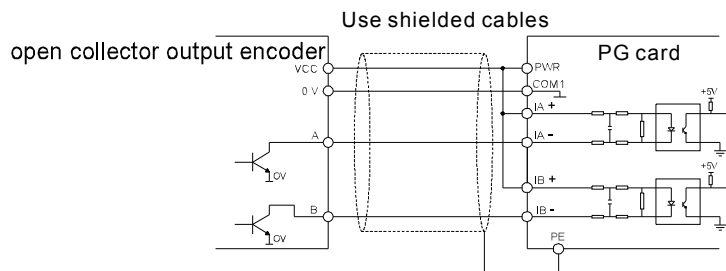

③ Wiring diagram of push-pull input encoder

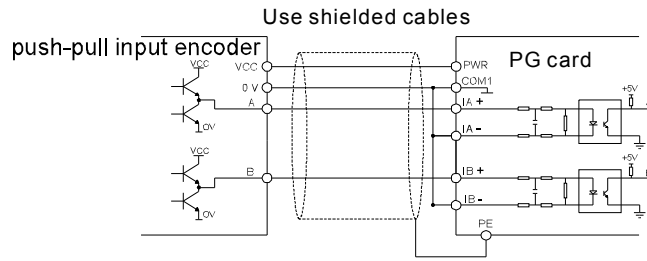

Note: Connect Z signal if supporting spindle positioning inverter, and the wiring is the same as A and B signal.

(8) Output application connection

① Wiring diagram of frequency division differential output of PG card

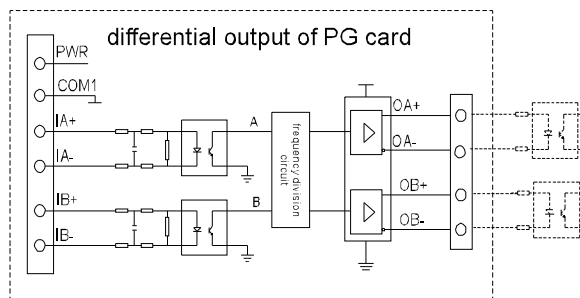

② Wiring diagram of frequency division open collector output of PG card

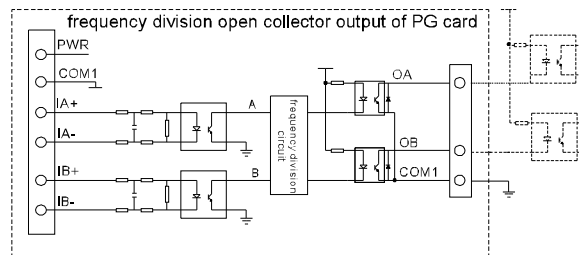

Note: PWR at J1 and J2 are short-connected with COA and COB in open collector output.

③ Wiring diagram of push-pull output of PG card

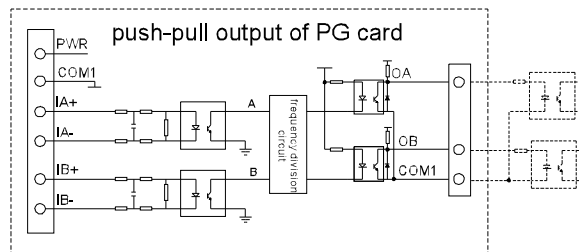

Note:

- ① PWR is short-connected with HOA and HOB at J1 and J2 in pull-push output.
- ② Incremental encoder PG card is mainly used in asynchronous motor closed-loop vector control.

8.1.3.2 Cosine encoder PG card and UVW encoder PG card

(1) Model and specifications

The technical features are as below:

Model	EC-PG102-05	EC-PG103-05
Frequency division factor	1 (No DIP switch)	1~256 (With DIP switch)
Output power supply	Voltage range: 4.75V~7V Factory setting: 5V/±5% Max. output current: 300mA	Voltage range: 4.75V~7V Factory setting: 5V/±5% Max. output current: 300mA
Output signal	Output: Two orthogonal frequency division differential output, open collector output Open collector output impedance: 70Ω	Output: Two orthogonal frequency division differential output, open collector output Open collector output impedance: 70Ω

The user can select the output voltage according to actual working, and in long-distance transmission, the power voltage can be adjusted through potentiometer to prolong the wiring distance.

(2) Dimensions and installation of UVW encoder PG card

Note:

- ① The installation and position of UVW encoder PG card is the same as that of incremental encoder PG card, corresponds to two rows of 2×10 pins.
- ② The installation and position of cosine encoder PG card is the same as that of UVW encoder PG card, but there is no DIP switch and the position of potentiometer is R101.

(3) Description of terminals and DIP switch

There are 1 signal interface and 7 wiring terminals on UVW encoder PG card and cosine encoder PG card.

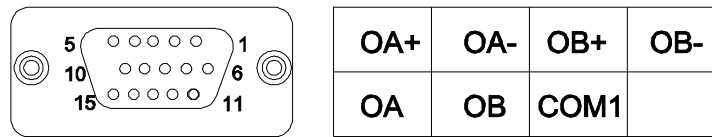

DB15

Frequency division output interface

Figure E-12 Interfaces and wiring terminal of PG card

OA+, OA-, OB+ and OB- are the signal frequency division output terminals. OA, OB and COM1 are open collector output terminals.

Note: The PE terminal of PG Card has not been connected to the earth; the user must connect the card to earth by themselves.

DB15 is the port of the encoder input signal. The order of the ports signal is as follow:

Ports	SIN/COS	UVW
5	A+	A+
6	A-	A-
8	B+	B+
1	B-	B-
3	R+	Z+
4	R-	Z-
11	C+	U+
10	C-	U-
12	D+	V+
13	D-	V-
9	PWR	PWR
7	GND	GND
14	Null	W

Ports	SIN/COS	UVW
15	Null	W-
2	Null	Null

During the application of above PG cards, insert the corresponding connecting wires of the signal arrangement of SIN/COS or UVW encoder and the synchronous PG card into DB15.

The frequency division factor of UVW encoder PG card is the same as that of the incremental encoder. Please refer to table 1-3.

Note :

- ① SIN/COS or UVW encoder PG card are mainly used on the close loop vector control of SM.
- ② UVW encoder PG card can process the 5V incremental encoder signal and the wiring is the same as that of the incremental encoder. The main wiring ports are A, B, Z, PWR and GND on DB15.

8.1.4 RST signal detection board

Note: RST signal detection board is used in Goodrive800 series rectifier control units. The lot No. is 17001-01058(380V) and 17001-01077(660V).

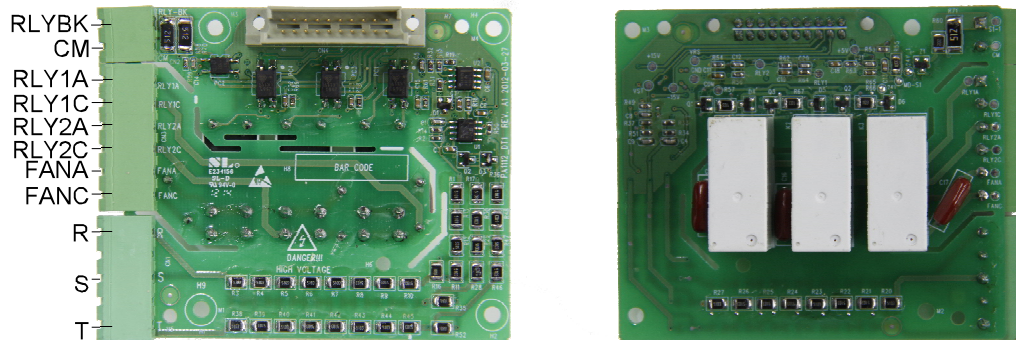

On the back of the control board.

Terminal structure:

RLYBK	CM	RLY1A	RLY1C	RLY2A	RLY2A	FANA	FANC	R	S	T
-------	----	-------	-------	-------	-------	------	------	---	---	---

Terminal description:

Sign	Description
R	Detect the input voltage R,S,T
S	
T	
FANA	External fan control
FANC	FANA NO, FANC common terminal
RLY1A	Main contact control
RLY1C	RLY1A NO, RLY1C common terminal
RLY2A	Buffer contact control
RLY2C	RLY2A NO, RLY2C common terminal
CM	Common feedback terminal of main contact
RLYBK	Feedback signal of main contact

8.1.5 Temperature detection board

Note: Temperature detection board is used in Goodrive800 series inverter control units. The lot No. is 17001-01024.

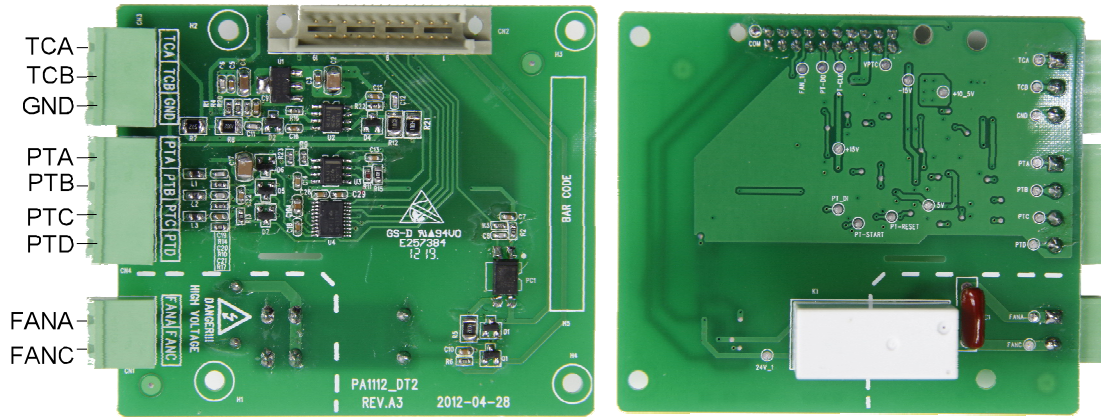

On the back of the control board with the RST signal detection board.

Terminal structure:

TCA	TCB	GND	PTA	PTB	PTC	PTD	FANA	FANC
-----	-----	-----	-----	-----	-----	-----	------	------

Terminal description:

Sign	Description
FANC	External fan control
FANA	FANA NO, FANC common terminal
PTA	PT100 temperature detection signal input port PTB, PTC and PTD connect to three-wire PT100
PTB	
PTC	
PTD	
GND	Grounding reference
TCA	NTC,PTC temperature detection signal input port
TCB	



Service line:86-755-86312859 E-mail:overseas@invt.com.cn Website:www.invt.com

SHENZHEN INVT ELECTRIC CO., LTD.

No. 4 Building, Gaofa Scientific Industrial Park, Longjing, Nanshan District, Shenzhen, China

- | | | | | |
|---------------------|--------------------------|---------------------------------------|------------------|-----------------------------------|
| Electric Drive: | ■ Frequency Inverter | ■ Intelligent Elevator Control System | ■ Traction Drive | |
| Industrial Control: | ■ Servo & Motion Control | ■ Motor & Electric Spindle | ■ PLC | ■ HMI |
| New Energy: | ■ SVG | ■ Solar Inverter | ■ UPS | ■ Online Energy Management System |



66001-00131