

Oil & Gas applications

Content

The company	02
Our vision	03
Our mission	03
Marelli Motori Group of companies	04
Core markets	06
Our commitment to quality	08
Inspired solutions	10
No compromise on quality	11
Highest efficiency standard	11
Reliable expertise	12
Serviceability	12
Sustainable approach	12
Oil & Gas applications	14
Motor applications	15
Generator applications	15
AVRs	16
Services	17
Industry standard	18
Motor applications	40
Product map	41
Motor range	41
Selection table	42
TEFC Non sparking motors Ex nA II C T3 Gc:	43
• B5N - B5L	
TEFC Flameproof motors Ex d/(de) II B T4 Gb:	46
• D5H - D5L - D6C - D5C - D5F - D6X - D5X - D5S	
TEFC Flameproof motors Ex d/(de) I Mb:	49
• D5T - D5U	
TEFC Flameproof motors Ex d/(de) II C T4 Gb:	51
• D6K - D5K - D5R - D5Y- D6Y - D5V - D5Y - D6Y	
Generator applications	54
Product map	55
Generator range	55
ODP generators: MJH	56
TEAAC generators: MJHV	60
ODP generators: MJB	65
TEAAC generators: MJV	69
Testing facilities	74
Facilities	75
Routine test and type test	75
Special testing	76
Services	78
Our service team	79
Aftersales services	79



The company

Our vision	03
Our mission	03
Marelli Motori Group of Companies	04
Core markets	06
Our commitment to quality	08

Vision

To become the global market leader of electric rotating machines in all our core markets.

Mission

Our mission is to aid the sustainable growth of our customers' businesses.

We will provide innovative solutions inspired by relentless efforts to understand our customers' needs and their specific applications.

We will leverage our extensive technical knowledge, product performance and service to increase the competitiveness, efficiency and productivity of our partners worldwide.



Marelli Motori Group of Companies

The Marelli Motori Group is one of the world's leading designers and manufacturers of generators and electric motors. The company was founded in 1891 and nowadays enjoys worldwide brand recognition thanks to its extended sales, distribution and service networks across four continents and two manufacturing facilities, based in Italy and Malaysia, which produce technologically advanced products sold in more than 120 countries.

Our business model is based on a successful combination of four key elements that enable Marelli Motori to offer innovative and inspired solutions which create value for our customers:

- wide range of innovative products
- skilled people providing sales & support globally
- local for local approach
- continuous investment in R&D.



SOUTH AFRICA
Johannesburg

GERMANY
Elze

UNITED KINGDOM
Leicester

UAE
Dubai

USA
Norcross

ITALY - HEADQUARTERS
Arignano

MALAYSIA
Kuala Lumpur

SPAIN
Barcelona

Core markets

Marelli Motori operates in six key markets:

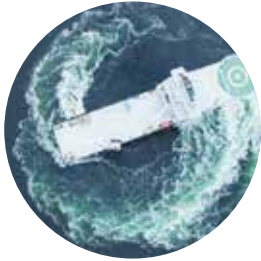

Marine

Marelli Motori manufactures electric motors and generators for all marine applications where power is required.

Our product applications include:

- propulsion, thrusters, FI-FI system, auxiliaries, dredge pumps, winch and PTO-PTI system
- shaft generators, hybrid machines, offshore, generators at variable speed and emergency.

Motors up to 10.000 kW

Generators up to 12.500 kVA



Power generation

Marelli Motori manufactures generators for all applications where energy is required.

Our product applications include:

- Prime Rated Power (PRP) and Continuous Operating Power (COP)
- stand by
- emergency
- Uninterruptible Power Supply (UPS)
- telecom.

Generators up to 12.500 kVA



Cogeneration (CHP)

Marelli Motori manufactures electric generators for combined heat and power applications.

Our product applications include:

- internal combustion (diesel and gas) engines
- steam and gas turbines.

Generators up to 12.500 kVA



Oil & Gas

Marelli Motori manufactures electric motors and generators for the oil and gas market.

Our product applications include:

- power generation, auxiliary generators and emergency
- centrifugal & reciprocating compressor motors
- heat exchangers & blowers
- pumps (pipeline, water, transfer, cooling, booster)
- extruders / expanders, conveyor system
- mixers, mills and cranes.

Motors up to 1.600 kW

Generators up to 12.500 kVA



Hydropower

Marelli Motori manufactures electric synchronous and asynchronous generators for hydro power plants which can be utilized in any turbine installation.

Our product applications include:

- Pelton turbines
- Francis turbines
- Kaplan turbines
- Turgo turbines
- Cross-Flow turbines.

Asynchronous generators up to 2.800 kW

Synchronous generators up to 9.000 kVA



Industrial

Marelli Motori manufactures electric motors for a wide variety of industrial applications.

Our product applications include:

- power
- metals
- pulp and paper
- cement
- sugar mill
- water pumping and treatments
- manufacturing processes
- mining
- chemical.

Motors up to 10.000 kW

Our commitment to quality

Quality certifications

The Marelli Motori Group uses an Integrated Management System (IMS) which monitors quality, health and safety and environment standards according to ISO 9001, ISO 14001 and OHSAS 18001.

Our quality certifications guarantee the highest standards in all areas of our operations to ensure:

- outstanding product quality allied to best-in-class service performance
- market leading customer satisfaction by ensuring compliance with all customer requirements from product reliability through to durability and ease of maintenance
- a safe place to work in
- minimal environmental impact in all our operations.



Our quality strategy

The Marelli Motori commitment to quality involves all employees from the boardroom to the shopfloor. Our aim is to help our employees to:

- develop a culture of quality, heightening awareness of quality issues, skills with appropriate and information
- ensure all employees comply with relevant quality regulations and procedures for the highest product quality, health and safety, and environmental standards
- plan and organise their activities with customer-oriented logic with customer satisfaction the ultimate goal at all times
- continuous evaluation of employee proposals for the improvement of processes defining key objectives and goals for the minimisation of environmental impact and health and safety risks of the personnel involved
- develop a culture where individual behavior leads to a safer and healthier workplace
- increase the awareness and involvement of all employees in work-related safety issues
- promote the Marelli Motori commitment to health and safety amongst the entire supply base ensuring a mutually beneficial relationship, enhancing the ability of both to create value.





Inspired solutions

No compromise on quality	11
Highest efficiency standard	11
Reliable expertise	12
Serviceability	12
Sustainable approach	12

No compromise on quality

Vertical manufacturing

Marelli Motori's manufacturing process is vertically integrated which ensures we retain control of our supply chain both upstream and downstream.

High quality materials

Our products are manufactured using the highest quality materials and components from internationally recognised brands which are regularly audited to maintain standards.

Our electrical machines are designed and engineered to ensure a long production life, using components, which have been developed for the most demanding environmental conditions requirements.

Outstanding vibration resistance

Our products are required to work in very harsh environments, whilst maintaining the highest standards of reliability and efficiency. As a result, we have developed a range of sturdier mechanical designs, able to withstand extreme vibration levels and shock, above 16 mm/sec RMS.

Special impregnation process

The durability of our electrical core components is vitally important in maintaining uptime and productivity. As a result we have developed our own VPI (Vacuum Pressure Impregnation) process in-house, which ensures that the machine windings are sealed against moisture and vibration, in turn aiding mechanical strength and reliability.

Specific coatings are applied on external surfaces in order to ensure that our products are fully protected when installed in harsh and aggressive environments.

International certifications

Independent accreditation is important for your peace of mind. Our motors comply with IECEx, ATEX directive 94/9/EC, SABS and Cu-Tr (formerly Gost) and are certified by third party international societies, such as CESI, BV, TUV etc. Our testing activities can be witnessed first-hand by customers.

Highest efficiency standards

We specialise in offering customers the highest levels of generator and motor efficiency via the use of technologically advanced solutions.

Our motors and generators are specifically designed to reach exceptionally high performance standards at any speed and during partial load operations.

Machine arrangements are suitable for variable speed applications, offering best-in-class energy efficiency levels to keep energy costs under control with no compromise on productivity.

Marelli Motori dedicated solutions can exceed 98% efficiency.

Reliable expertise

Extensive and diverse product range

Our comprehensive range of motors and generators have been specifically designed to match the diverse requirements of our customers, offering state-of-the-art solutions backed by outstanding application expertise.

Continuous enhancement through R&D

Our R&D focus is driven by a deep customer understanding which is then converted into product development and continuous range enhancement. We often develop projects in partnership with customers, for example developing very compact designs to suit narrow spaces.

Design flexibility

Our flexibility even reaches final assembly, a point at which customers are still able to adapt a design to meet the requirements of their specific application.

Once in the field, our products can be equipped with a range of retrofit devices enabling the continuous refinement and upgrading of machine performance.

Reliable performance

Non-stop operations can be undertaken during ancillaries replacement and mirror system devices for back-up are standard features.

All of our products are extensively tested in our in-house laboratories, with tests including the string test type, to ensure the correct evaluation of electrical and mechanical performances in any working conditions.

Serviceability

Our motors and generators have been specifically designed for ease-of-maintenance, offering quick access to key components to facilitate MRO activities and reduce servicing costs.

All of our products have a friendly user-interface which, together with a global service network available worldwide, ensures best-in-class performance and high ROI.

Sustainable approach

Safety first

All Marelli Motori manufacturing sites comply with the International Standards for Safety OH SAS ISO 18000 (Occupational Health and Safety Assessment Series).

Low carbon footprint

Marelli Motori products are designed to deliver maximum performance and high energy efficiency to achieve the lowest carbon footprint possible.

For example, the energy recovery process in place during test room activities enables us to reduce the impact on the environment and mitigate global warming.

Social responsibility

Marelli Motori's approach to social responsibility is based upon minimising our impact on the environment and preserving the world's natural resources.

A key part of this approach is engage, with all of our stakeholders, including our supply chain and customers, partnering with universities for research and development and supporting local communities with charity activities.





Oil & Gas applications

Motor applications	15
Generator applications	15
AVRs	16
Services	17
Industry standard	18

Motor applications

Our motors are suitable for the following Oil & Gas applications:

- centrifugal & reciprocating compressor
- heat exchangers and blowers
- pumps
- extruders and expanders
- conveyor systems
- mixers
- mills
- cranes.



TEFC
Non sparking
motors
Ex nA II C T3 Gc
B5N - B5L
up to 1.600 kW



TEFC
Flameproof motors
Ex d/(de) II B T4 Gb
D6C - D5C - D5F - D5H
D6X - D5X - D5S - D5L
up to 925 kW



TEFC
Flameproof motors
Ex d/(de) I Mb
D5T
D5U
up to 240 kW



TEFC
Flameproof motors
Ex d/(de) II C T4 Gb
D6K - D5K -D5R
D6Y - D5Y - D5V
up to 200 kW

Generator applications

Our generators are suitable for the following Oil & gas applications:

- power generation
- auxiliary generators
- emergency.



ODP
MJH
up to 12.500 kVA



TEAAC
MJHV
up to 8.750 kVA



ODP
MJB
up to 6.500 kVA



TEAAC
MJV
up to 4.550 kVA

Key

ODP Open Drip Proof

TEFC Totally Enclosed Fan Cooled

TEAAC Totally Enclosed Air to Air Cooled

AVRs

Digital Regulators

Marelli Motori digital regulation systems provide functional and reliable solutions for the excitation control of synchronous generators. These highly integrated and robust AVRs are fully configurable and guarantee easy commissioning, monitoring and maintenance by user-friendly proprietary HMI (human-machine interface) software.

A wide range of built-in control functions, protections and operating modes make Marelli Motori digital AVRs flexible and suitable for a wide range of applications, including marine, hydro and cogeneration. Our automatic voltage regulator, MEC 100 is DNV type approved.

MEC 100

MEC 20
Three Phase

Analogue Voltage Regulators

Marelli Motori analogue regulation systems are suitable for low and medium voltage machines. The regulators are fully insulated in order to maintain high reliability also with severe ambient conditions (high level of humidity, dust, salt atmosphere) and in case of high vibration level. The AVRs can work both for single and three phase operations.

MARK V
Single Phase

MGC I
Single Phase

MGC II
Single Phase

MARK X*
Three Phase

* Dedicated for PMG.

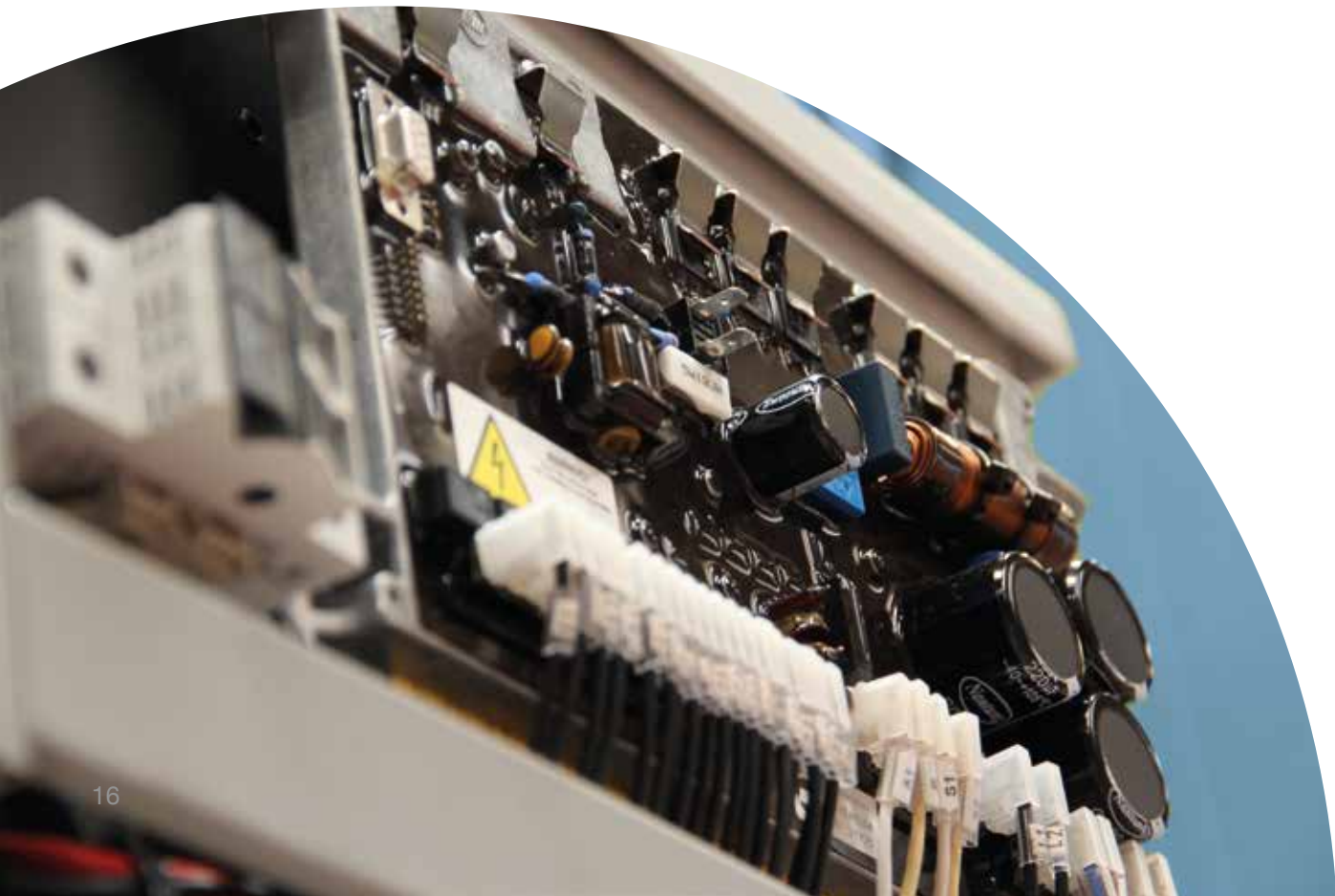

Services

When you partner with Marelli Motori, customers not only gain access to our outstanding portfolio of motors and generators but also world class aftersales support.



Technical support

Marelli Motori prides itself on providing outstanding technical and application support for all its products.

Qualified technical support personnel are always on hand to help with design, retrofitting and revamping solutions for machines and voltage/control systems.



Field Service

Our highly trained aftersales service technicians are capable of deploying, at short notice, anywhere in the world, rapidly diagnosing faults and ensuring fast and efficient maintenance and repair.



Spare parts

Genuine Marelli Motori spare parts are available at the Marelli headquarters, branch offices and service centres located all over the world.



Repairs

When a machine fails it is vital that a repair is performed quickly to ensure a swift return to operation. Marelli Motori can perform repairs of low, medium and high voltage machines either at our manufacturing facility or at the customer premises.



Commissioning

We understand that correct machine commissioning is vital in ensuring that our generators work to the best of their ability from day one.

Marelli Motori provides hands-on assistance during the commissioning phase, guaranteeing that start-up takes place safely and that correct functional parameters for each machine are applied.



Training

Training courses are available all year to users and maintenance people to ensure the correct operation and maintenance of our electrical machines.

Industry standards

EN / IEC standars

Marelli Motori refers to the IEC and EN standars which have been recently updated.

Standards for non - sparking atmosphere

Rating and Performance	IEC 60034 - 1
Classification of degrees of protection (IP code)	IEC 60034 - 5
Methods of cooling (IC code)	IEC 60034 - 6
Classification of type of construction and mounting arrangement (IM code)	IEC 60034 - 7
Terminal markings and direction of rotation	IEC 60034 - 8
Noise limits	IEC 60034 - 9
Starting performance of rotating electrical machines	IEC 60034 - 12
Mechanical vibration	IEC 60034 - 14
Relation between sizes and ratings of three-phase, short-circuit surface-cooled electric motors	IEC 60072 - 1
Dimensions and outputs for electrical machines	IEC 60072 - 2
Electrical apparatus for potentially explosive atmospheres – general requirements	IEC/EN 60079 - 0
Equipment protection by flameproof enclosures “d”	IEC/EN 60079 - 1
Equipment protection by increased safety “e”	IEC/EN 60079 - 7
Equipment protection by type of protection "n"	IEC/EN 60079 - 15

European directives

Marelli Motori motors fully comply with the following directives.

European directives

Directives for Explosive Atmosphere (ATEX)	2014/35/EU
Electromagnetic Compatibility (EMC)	2004/108/EC
Low Voltage Directive (LVD)	73/23/EEC
Machinery Directive	2006/42/EC

IECEX SCHEME

The objective of the IECEx System is to facilitate international trade in equipment and services for use in explosive atmospheres, while maintaining the required level of safety with the aim of a single global test and certificate.

The IECEx System is supported by three Conformity Assessment Schemes:

- **IECEX Certified Equipment.** IECEx certification provides assurance that the strictest safety requirements of IEC International Standards through:
 1. IECEx ExTR (Test Report)
 2. IECEx QAR (Quality Assessment Report)
 3. IECEx CoC (Certificate of Conformity)
- **IECEX Certified Service Facility.** It certifies that organizations and workshops that provide Ex equipment selection, design, installation, inspection, maintenance, repair, overhaul and reclamation services to the Ex industry do so respecting the strict requirements of IEC International Standards IEC 60079-14, IEC 60079-17 and IEC 60079-19.
- **IECEX Certification of Personnel Competence.** It provides assurance about persons that their knowledge and competence has been independently verified.

To achieve IECEx Product Certification is mandatory to involve an IECEx Approved Certification Body (IECEX ExCB) to test the products and samples according to the IEC Standards and issue the Test Report (IECEX ExTR).

IECEX Product Certifications also requires the involvement of an ExCB to audit the Quality Assurance System of the manufacturers that must be previously assessed and in conformity with ISO 9001. From the audit success a QAR (IECEX Quality Assessment Report) is issued.

With the ExTR, Product Documentation and QAR, the Certificate of Conformity (IECEX CoC) can be issued by the ExCB.

One of the benefits of the IECEx is to remove the costly duplication of testing/certs at local level being globally recognised from more than 160 countries and to remove delays to enter in new markets.

The IECEx scheme allow the instant access to information, including “On-Line” certificates so that everybody can do instant checking.



General aspects of ATEX Directives

An explosion can only take place if the following three factors coincide:

- combustible substances in the form of gases, vapours, mists or dusts
- oxygen (in the air)
- source of ignition (e.g. electrical spark).

If the concentration of combustible substances is too low or if the concentration is too high the explosion does not take place.

The explosion limits depend by the surrounding pressure and the proportion of oxygen in the air.

Sources of ignition can be :

- hot surfaces
- ultrasound
- radiations
- open flames
- chemical reaction
- electrostatic discharge
- mechanical sparks
- electrical sparks and arcs.

The ATEX Manufacturers Directive 94/9/EC, also known as ATEX 95, places the responsibilities on the manufacturers.

In order to meet the ATEX Directive, products must comply with the Essential and safety Requirements of this Directive and follow a Conformity Assessment Procedure.

This assessment procedure involves obtaining:

- the EC Type Examination
- the Production Quality Assurance
- an internal control of production.

To obtain the EC type examination and the production quality assurance the manufacturer requires the involvement of a notified body.

Products belonging to category 3 can be certified by the manufacturer itself.

The ATEX product markings can be easily recognized by the symbol Ex , that indicates the explosion protection and by the mark CE that certifies the conformity with this Directive.

The ATEX User Directive 99/92/EC, also known as ATEX 137, describes the minimum explosive atmospheres.

It classifies the environment into zones and outlines which category of equipment that can be used in each zone.

The relation between the two directives is shown below:

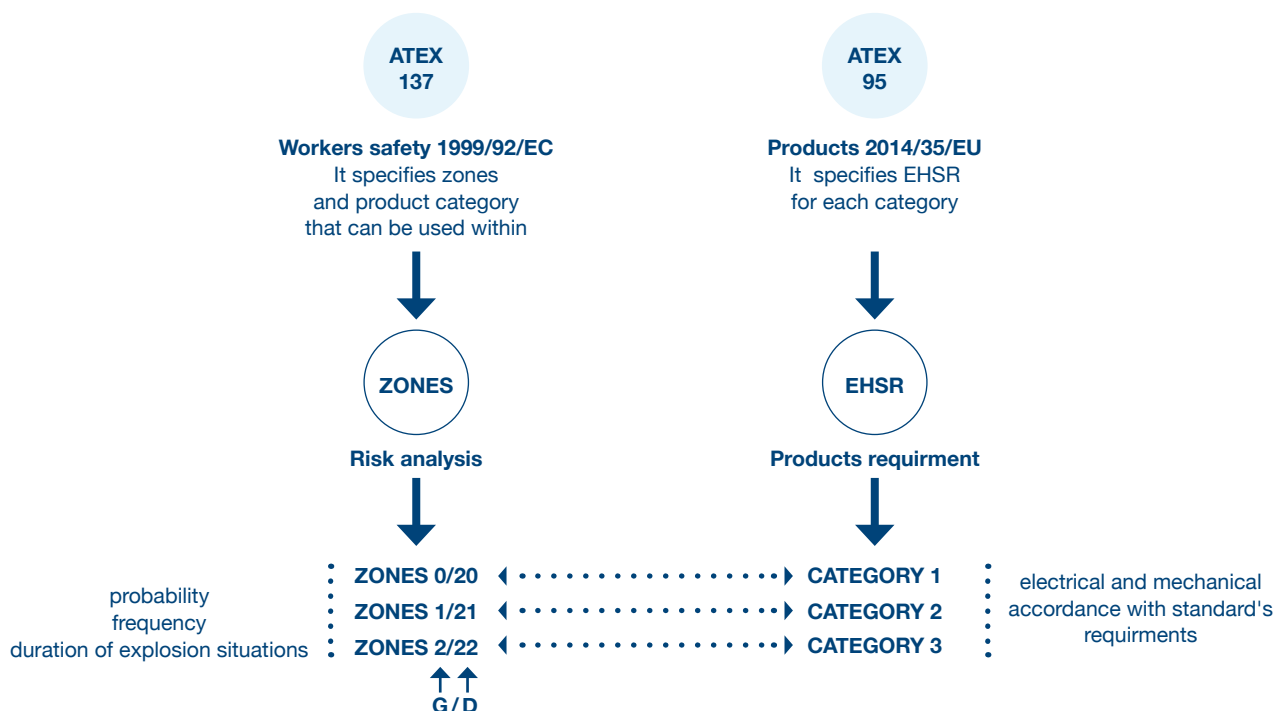

Explosive atmosphere and dangerous areas classifications

Dangerous environments are classified by zone, according to the risk generated by explosive gas or dust in the atmosphere.

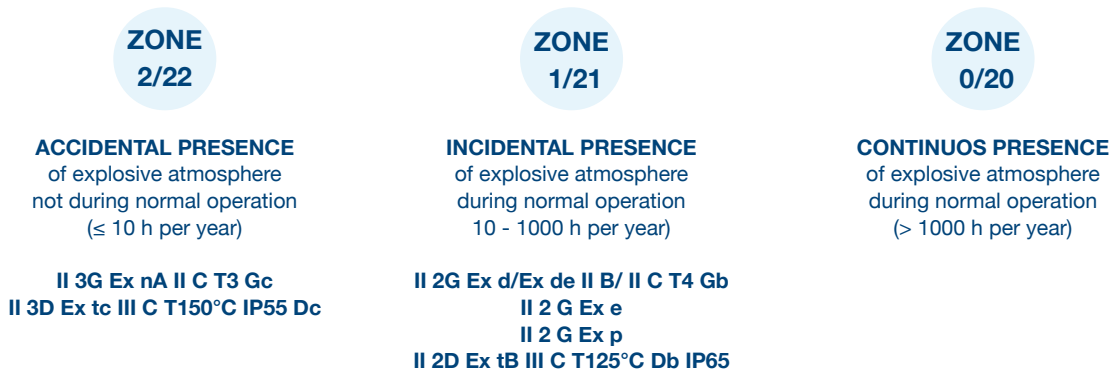

Classifications of explosive atmosphere according to IEC/EN

The classification of areas according to the presence of atmosphere are based on the following standards:

- EN 60079 -10 -1 Gas
- EN 60079 - 10 -1 Dust

Zone		Presence of potentially explosive atmosphere
Gas	Dust	
0	20	Always present , frequent or long lasting periods during normal operation. The use of electric motors is not allowed.
1	21	Incidental presence: likely to occur during normal operation of the equipment.
2	22	Accidental presence: unlikely to occur during normal operation of th equipment.

Groups and categories

- **Group I** comprises equipment intended for use in the underground parts of mines, and to those parts of surface installations of such mines, likely to become endangered by firedamp and/or combustible dust;
- **Group II** comprises equipment intended for use in other places likely to become endangered by explosive atmospheres.

These groups are sub-divided into Categories as shown below.

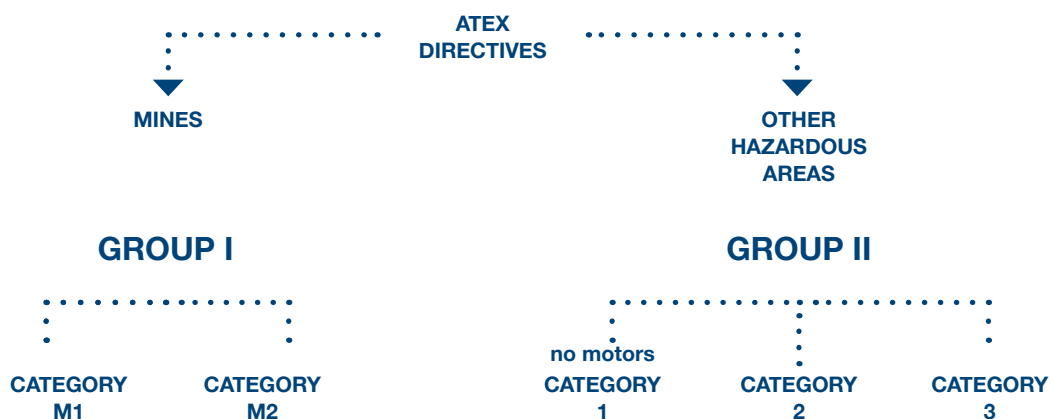

Gas atmosphere are further divided into 3 sub-groups, according to the severity of the environment:

Group	Danger rating	Examples of gas atmospheres
II A	Low	acetone, acetic acid, methanol, ethanol, benzene, ethane, methane, propane, toluene, xylene, combustible oil, kerosene, acetaldehyde, ethyl benzene, isoprene
II B	High	coke-oven gas, ethylene, ethylene oxide, ethyl ether, formic aldehyde
II C		hydrogen, acetylene, water gas, carbon sulphur

Equipment protection level (EPL)

An alternative procedure for classification of the Ex equipment into the hazardous areas is the system of Equipment Protection Level (EPL) in accordance with IEC 60079-26.

Equipment classification

Groups, Categories, Atmosphere, Type of protection, Temperature classes

For a safe use of electrical equipment in a potentially explosive atmosphere the following information must be known in advance:

- the environment in which the apparatus will operate
- the gas group
- the spontaneous ignition temperature of the gas mixture.

IEC/EN 60079-0			Eu Directive 2014/35/EU	IEC/EN 60079-10-X	
Equipment Protection level	Protection level	Group	Equipment group	Equipment category	Zones
Ma	Very high	I (Mines)	I (Mines)	M1	n/a
Mb	High			M2	
Ga	Very high	II (Gas)	II (Surface Industries)	1G	0
Gb	High			2G	1
Gc	Enhanced			3G	2
Da	Very high	III (Dust)		1D	20
Db	High			2D	21
Dc	Enhanced			3D	22

EPL Equipment Protection Level

Level of protection assigned to equipment based on its likelihood of becoming a source of ignition and distinguishing the differences between explosive gas atmospheres, explosive dust atmospheres and the explosive atmospheres in mains susceptible to firedamp.

- **Gb** for explosive gas atmospheres having a "high" level of protection, which is not a source of ignition in normal operation or during expected malfunctions
- **Gc** for explosive gas atmospheres having a "enhanced" level of protection, which is not a source of ignition in normal operation and which may have some additional protection to ensure that it remains inactive as an ignition source in the case of regular expected occurrences (for example failure of a lamp)

In IEC/EN 60079-0 a group III has been created for dusts. This is to allow the recognition of conductive and non-conductive dusts and flyings.

The three categories are defined below:

Group	IEC/EN 60079-10-2 Definition	Description
III A	Combustible flyings	solid particles, including fibres, greater than 500 µm in normal size, which may be suspended in air, may settle out the atmosphere under their own weight, can burn or glow in air, and may form explosive mixtures with air at atmospheric pressure and normal temperatures
III B	Non conductive dusts Electrical resistivity > 10 ³ Ωm	finely divided solid particles, 500 µm or less in nominal size, which may be suspended in air, may settle out of the atmosphere under their own weight, can burn or glow in air, and may form explosive mixtures with air at atmospheric pressure and normal temperatures
III C	Conductive dusts Electrical resistivity ≤ 10 ³ Ωm	

Temperature classes

For gas environments

The electrical equipment is classified into 6 classes according to the maximum surface temperatures, which is:

- the temperature of the external surfaces for motors with protection mode "d"
- the temperature of any internal and external point for motors with protection mode "e" or "n".

The maximum surface temperature of the equipment must remain lowest possible ignition temperature of the atmosphere surrounding it.

Temperature class	Ignition Temperature for the gas/vapour °C	Max Permitted Temperature °C
T1	< 450	450
T2	300 < T < 450	300
T3	200 < T < 300	200
T4	135 < T < 200	135
T5	100 < T < 135	100
T6	85 < T < 100	85

Flammable gases and vapors

Temperature class	Ignition Temperature °C	Temperature class	Explosion group
1,2-dichloroethane	440 °C	T2	II A
Acetaldehyde	140 °C	T4	II A
Acetone	540 °C	T1	II A
Acetylene	305 °C	T2	II C ⁽³⁾
Ammonia	630 °C	T1	II A
Petroleum spirit, gasoline, initial boiling > 135 °C	220 ... 300 °C	T3	II A
Benzene (pure)	555 °C	T1	II A
Cyclohexanone	430 °C	T2	II A
Diesel fuels (DIN 51601)	220 ... 300 °C	T3	II A
Jet fuel	220 ... 300 °C	T3	II A
Acetic acid	485 °C	T1	II A
Acetic acid and anhydride	330 °C	T2	II A
Ethane	515 °C	T1	II A
Ethyl acetate	460 °C	T1	II A
Ethyl alcohol	425 °C	T2	II A / II B
Ethyl chloride	510 °C	T1	II A
Ethylene	425 °C	T2	II B
Ethylene oxide	440 °C (self decomposing)	T2	II B
Ethyl ether	170 °C	T4	II B
Ethylene glycol	235 °C	T3	II B
EL heating oil (DIN 51603)	220 ... 300 °C	T3	II A
L heating oil (DIN 51603)	220 ... 300 °C	T3	II A
M and S heating oils (DIN 51603)	220 ... 300 °C	T3	II A
i-amyl acetate	380 °C	T2	II A
Carbon monoxide	605 °C	T1	II A / II B
Methane	595 (650) °C	T1	II A
Methanol	455 °C	T1	II A
Methyl chloride	625 °C	T1	II A
Napthalene	540 °C	T1	II A
n-butane	365 °C	T2	II A
n-butyl alcohol	340 °C	T2	II A
n-hexane	240 °C	T3	II A
n-propyl alcohol	405 °C	T2	- ^(*)
Oleic acid	360 °C (self decomposing)	T2	- ^(*)
Phenol	595 °C	T1	II A
Propane	470 °C	T1	II A
Carbon disulfide	95 °C	T6	II C ⁽¹⁾
Hydrogen sulfide	270 °C	T3	II B
Special petroleum spirits, initial boiling point < 135 °C	220 ... 300 °C	T3	II A
City gas (illumination gas)	560 °C	T1	II B
Tetralin (tetrahydronaphthalene)	425 °C	T2	- ^(*)
Toluene	535 °C	T1	II A
Hydrogen	560 °C	T1	II C ⁽²⁾

Extract from the table "Safety parameters for combustible gases and vapors" by K. Nabert and Schön (6th Edition)

(*) The explosion group has not been established for this substance.

(1) Also Explosion Group II B + CS2

(2) Also Explosion Group II B + H2

(2) Also Explosion Group II B + C2 H2

Marking

Marking of equipment

According to the 94/4/EC Directive, motors come with 3 markings, in order to let the user check the compatibility between the protection made of the motor and the classification of the area of its installation:

CE Marking 		European Community
	0722	Identification of notified body 0722 = CESI
Specific Marking 		European Commission mark for Ex products
	II	Equipment Group: II for surface Industries I for mines
	3	Equipment category 2 for zone 1 or 21 3 for zone 2 or 22
	G	Atmosphere G for gas D for dust

Complementary marking

Ex nA	Protection type Ex d, Ex de, Ex e, Ex nA
II C	Sub-group of gas II A, II B, II C
T3	Temperature class (T3 ÷ T5)
Gc	EPL Gb Gc
Ex tc	Protection by enclosure
III C	Installation in zone 21
T 125°C	Max surface temperature
IP 65	IP protection
Dc	EPL Db Dc

Protection Type Ex d - Explosion proof motors

EN/IEC 60079 - 1

Ex d protection is relevant the enclosure of the equipment. This type of protection does not cover measures to prevent the formation of a potentially explosive atmosphere. The safety level on an explosion proof motor is on the fact that it must ensure to withstand an internal explosion without transmitting it to the external environment. This is achieved with regard to the specific type of gas present on the atmosphere and therefore the relevant group.

Electrical equipment with approval for explosion group IIC can also be used in explosion groups II A and II B.

Internal pressure that can result of an explosion in the interior of the motor have to be withstood by the main components (frame, endshields, internal bearing covers, terminal boxes). To achieve the above mentioned protection, related standard establishes minimum dimension of joints and gaps that has to be respected and sets up tests that has to be carried out.

Ex d motors are certified by a Notified Body to be suitable for operation in zone 1.

Protection Type Ex de – Explosion Proof Motors with an increased safety terminal box

EN/IEC 60079 - 1 and EN/IEC 60079 - 7

This type of protection is a combination of a Ex d housing with an Ex e terminal box.

The terminals and terminal box are designed to provide increased security against the possibility of excessive temperatures and of the occurrence of arcs and sparks in normal service or under specified abnormal conditions.

To achieve the above mentioned protection, related standard establishes characteristics of material, creepage distances and clearances, minimum air gap and other details such devices to prevent rotation of cables.

Ex de motors are certified by a Notified Body to be suitable for operation in zone 1.

Protection Type Ex nA – non sparking motors

EN/IEC 60079-15

Type of protection applied to electrical apparatus to prevent the potentially explosive atmosphere in normal operations which excludes thermal requirements due to starting or accidental stalling.

Marelli Motori design this range of motors with special attention to prevent the ignition and to minimize the risk of occurrence of arcs or sparks capable of creating an ignition and to prevent that the internal and external surfaces temperatures do not overpass the maximum surface temperature certified.

This type of protection is similar to the protection “e” but it is less strict concerning the materials, the abnormal conditions and the creepage distances and clearances.

Ex nA motors don't require certification by a third party Notified Body .

The manufacturer conformity declaration is accepted.

Industry standards

IP Code - Degree of protection (IEC - 60034 - 5)

First number		Second number	
2	Machine protected against solid objects greater than 12 mm	2	Dripping water shall have no harmful effect from the vertical up to an angle up to 15°
3	Machine protected against solid objects greater than 2,5 mm	3	Spraying water shall have no harmful effect from the vertical up to an angle up to 60°
4	Machine protected against solid objects greater than 1 mm	4	Splashing water from any direction shall have no harmful effect
5	Machine protected against cust	5	Jets of water from any direction shall have no harmful effect
6	Machine totally protected against tight dust	6	Jets of water from heavy seas from any direction shall have no harmful effect

Example of designation - IP 44

IP	Code IP
4	First number (protection against dust)
4	Second number (protection against liquid)

IC Code - Cooling (IEC - 60034 - 6)

Typical fluids

A	Air
W	Water

Typical circuit arrangements

0	Free circulation
4	Machine surface - cooled
6	Heat exchanger machine mounted (using the motor surrounding coolant)
7	Heat exchanger built in the machine (not using the motor surrounding coolant)
8	Heat exchanger machine mounted (not using the motor surrounding coolant)

Typical methods of circulation

0	Free circulation
1	Self circulation
6	Circulation with independent device

Example of designation - IC 411

IC	Code IC
4	Circuit arrangement
A	Primary fluid
1	Method of circulation for primary fluid
A	Secondary fluid
1	Method of circulation for secondary fluid

Mounting

IEC - 60034 - 7

Mounting and positions are defined by the following codes according to IEC 60034 - 7:

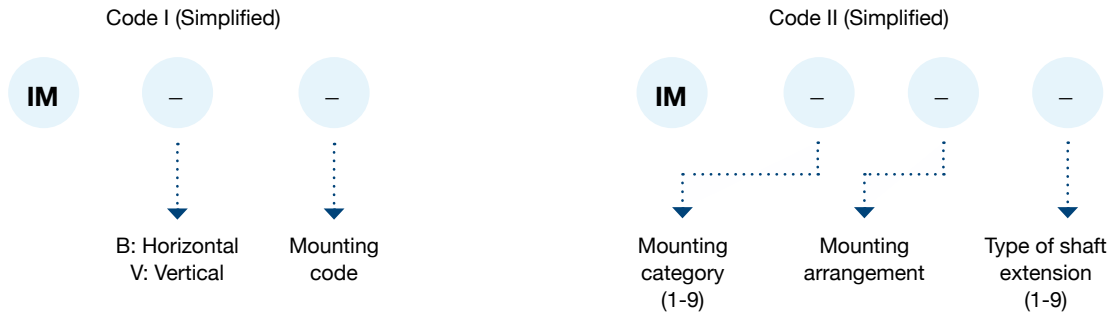

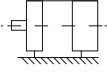
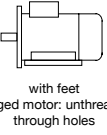
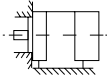
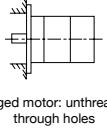
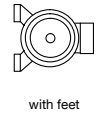
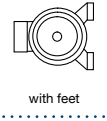
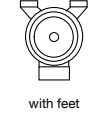
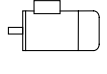
IEC 60034-7			Frame size							
Code I	Code II	Mount	71-132	160-250	280	315 M	315 L	355	400	450
IM B3	IM 1001	 whit feet	Standard	Standard	Standard	Standard	Standard	Standard	Standard	Standard
IM B35	IM 2001	 with feet flanged motor: unthreaded through holes	Standard	Standard	Standard	Standard	Standard	Standard	Standard	Standard
IM B34	IM 2001	 with feet	Standard	Not applicable	Not applicable	Not applicable	Not applicable	Not applicable	Not applicable	Not applicable
IM B5	IM 3001	 flanged motor: unthreaded through holes	Standard	Standard	Contact Marelli Motori	Contact Marelli Motori	Contact Marelli Motori	Contact Marelli Motori	Not applicable	Not applicable
IM B6	IM 1051	 with feet	Standard	Standard	Contact Marelli Motori	Contact Marelli Motori	Contact Marelli Motori	Contact Marelli Motori	Not applicable	Not applicable
IM B7	IM 1061	 with feet	Standard	Standard	Contact Marelli Motori	Contact Marelli Motori	Contact Marelli Motori	Contact Marelli Motori	Not applicable	Not applicable
IM B8	IM 1071	 with feet	Standard	Standard	Contact Marelli Motori	Contact Marelli Motori	Contact Marelli Motori	Contact Marelli Motori	Not applicable	Not applicable
IM B14	IM 3601		Standard	Not applicable	Not applicable	Not applicable	Not applicable	Not applicable	Not applicable	Not applicable

IEC 60034-7			Frame size							
Code I	Code II	Mount	71-132	160-250	280	315 M	315 L	355	400	450
IM V1	IM 3011	 flanged motor: unthreaded through holes	Standard	Standard	Standard	Standard	Standard	Standard	Standard	Standard
IM V15	IM 2011	 with feet flanged motor: unthreaded through holes	Standard	Standard	Standard	Standard	Standard	Standard	Standard	Standard
IM V3	IM 3031	 flanged motor: unthreaded through holes	Standard	Standard	Contact Marelli Motori	Contact Marelli Motori	Contact Marelli Motori	Contact Marelli Motori	Not applicable	Not applicable
IM V36	IM 2031	 with feet flanged motor: unthreaded through holes	Standard	Standard	Contact Marelli Motori	Contact Marelli Motori	Contact Marelli Motori	Contact Marelli Motori	Not applicable	Not applicable
IM V5	IM 1011	 with feet	Standard	Standard	Contact Marelli Motori	Contact Marelli Motori	Contact Marelli Motori	Contact Marelli Motori	Not applicable	Not applicable
IM V6	IM 1031	 with feet flanged motor: unthreaded through holes	Standard	Standard	Contact Marelli Motori	Contact Marelli Motori	Contact Marelli Motori	Contact Marelli Motori	Not applicable	Not applicable
IM V18	IM 3611	 with feet	Standard	Not applicable	Contact Marelli Motori	Contact Marelli Motori	Contact Marelli Motori	Contact Marelli Motori	Not applicable	Not applicable
IM V19	IM 3631	 with feet	Standard	Not applicable	Not applicable	Not applicable	Not applicable	Not applicable	Not applicable	Not applicable

For other mounting arrangements refer to IEC 60034-7. The motors should be installed on a rigid foundation with negligible structural vibrations. Feet can be removed for motors with frame sizes 71 to 132.

Technical specification

Materials

Mounting and positions are defined by the following codes according to IEC 60034 - 7:

Components	Frame Size 71 - 315	Frame Size 355 - 400	Frame Size 450
Frame	Cast Iron	Cast Iron	Cast Iron
Endshields	Cast Iron	Cast Iron	Cast Iron
Fan cowl	Steel	Fibreglass	Fibreglass
Fan	Thermoplastic	2 poles polyamide ≥4 poles aluminium	poles polyamide ≥4 poles aluminium
Terminal Box ¹	Cast Iron	Cast Iron	Steel

¹ Terminal box casted with frame for 71 and 80 sizes

² Motors for low temperature duty are made of steel

Insulation class F

Class F insulation systems are utilised in Marelli Motori motors.

This is the most common requirement among the industry today. The class F insulation system allows a temperature rise of 105K, measured by the resistance variation method, and a maximum hot spot temperature value of 155°C. The materials and the impregnation systems used make these motors suitable for use in tropical environments, for applications with high vibrations and for applications with high thermal variations. Insulation class H can be provided on request.

Temperature rise compatible with class B

Class B rise allows a maximum winding temperature rise of 80K under normal running conditions (rated voltage, frequency and load) with maximum ambient temperature of 40°C and altitude below 1000m a.s.l.

Installation 1000 m a.s.l.

The performance of standard motors is considered at a maximum height of 1000m above sea level (a.s.l.) with motors running in continuous duty, at nominal voltage and frequency.

Bearings

Bearings for Ex d IIB - Ex nA - Ex d I

Frame size	D-end		N-end	
	Horizontal and Vertical	Horizontal	Horizontal	Vertical
71	6202-2Z		6202-2Z	
80	6204-2Z		6204-2Z	
90	6205-2Z		6205-2Z	
100	6206-2Z		6206-2Z	
112	6206-2Z		6206-2Z	
132	6308-2Z		6308-2Z	
160	6310-Z -CM		6209-Z -CM	
180 M IE1	6310-Z -C3		6209-Z -C3	
180 IE2	6310-Z -C3		6210-Z -C3	
200	6312-Z -C3		6210-Z -C3	
225	6313-Z -C3		6213-Z -C3	
250	6314-Z -C3		6213-Z -C3	
280 2 poles	6314-Z-C3		6314-Z-C3	
280 >= 4 poles	NU2217-EC-C3		6314-Z-C3	
315 -2 poles	6316-C3		6316-C3	
315 M >= 4 poles	NU2219-EC-C3		6316-C3	
315 L >= 4 poles	6319-C3		6316-C3	
355 2 poles	6317-C3	6317-C3		7317-BE
355 >= 4 poles	6322-C3	6322-C3		6322-C3
400 2 poles	6317-C3	6317-C3		7317-BE
400 LA-LB >= 4 poles	6322-C3	6322-C3		6322-C3
400 LC-LD >= 4 poles	6322-C3	6322-C3		7322-BE
450 2 poles	6320-C3	6320-C3		7320-BE
450 >= 4 poles	6326-C3	6326-C3		7326-BC

Bearings for Ex d IIC

71	6202-2Z-C3		6202-2Z-C3	
80	6204-2Z-C3		6204-2Z-C3	
90	6205-2Z-C3		6205-2Z-C3	
100	6206-2Z-C3		6206-2Z-C3	
112	6206-2Z-C3		6206-2Z-C3	
132	6308-2Z-C3		6308-2Z-C3	
160	NU 210 E -C3		6209-Z -C3	
180 M IE1	NU 210 E -C3		6210-Z -C3	
180 IE2	NU 210 E -C3		6210-Z -C3	
200	NU 212 E -C3		6210-Z -C3	
225	NU 213 E -C3		6213-Z -C3	
250	NU 214 E -C3		6213-Z -C3	
280 2 poles	6314-Z-C3		6314-Z-C3	
280 >= 4 poles	NU2217-EC-C3		6314-Z-C3	
315 -2 poles	6316-C3		6316-C3	
315 >= 4 poles	NU2219-EC-C3		6316-C3	

Re-greasing systems are normally supplied for frame size 280 and 315. On request, regreasing systems are available from frame size 160 to 250.

Radial Loads

The maximum allowable radial forces at the shaft extension (Xmax) and at the shaft collar (Xo) for motors having the following characteristics:

- standard construction
- horizontal mounting (Mounting arrangement IM B3, IM B35 only)
- operating frequency 50Hz
- bearing life of 20 000 hours (according to ISO 281:1990)
- bearing operating temperature between -20 and +70°C
- no external axial forces
- motor installed on a rigid foundation with negligible structural vibrations; are shown in the following table.

Frame size	2 poles		4 poles		6 poles		8 poles	
	F _{Xo}	F _{Xmax}	F _{Xo}	F _{Xmax}	F _{Xo}	F _{Xmax}	F _{Xo}	F _{Xmax}
71	440	365	550	450	635	500	690	505
80	665	540	835	680	965	740	1100	745
90	730	610	950	785	1110	920	1260	1060
100	1050	855	1320	1080	1560	1270	1770	1450
112	1700	1230	1980	1510	2210	1530	2500	1470
132	2270	1740	2720	2110	3100	2490	3580	2880
160	3000	2400	3600	2000	4300	2000	4500	2000
180	3000	2400	3650	2500	4300	2500	4900	2500
200	1390	950	1390	950	1390	950	1390	950
225	4550	3800	5400	3800	6300	3800	7000	3800
250	3260	2000	3260	2000	3260	2000	3260	2000
280	4600	3750	See construction for high radial loads					
315 M	6100	3530	See construction for high radial loads					
315 L	7030	4490	10590	5580	11250	5580	/	/
355 L	4300	2200	9000	6500	9800	3400	9800	3000
400 LA-LB	3600	2000	9000	7800	10500	4500	- / 2000	- / 1000
400 LC-LD	1000 / -	500 / -	2000 / -	1000 / -	300	300	300	300
450 L	3400	3100	5500	4800	5600	3000	2000	1000

Forces [N]

The maximum radial loads between the values Xo=0 and Xmax=E can be determined from the following linear relationship.

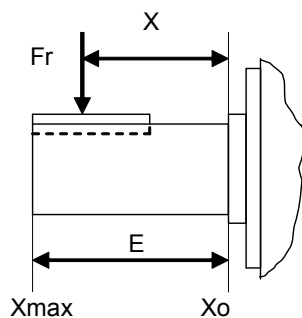

$$F_r = F_{x_o} - \frac{X}{E} (F_{x_o} - F_{x_{max}})$$

F_{x_o} = maximum radial load at the shaft collar [N].

$F_{x_{max}}$ = maximum radial load on the end of the shaft extension [N].

E = shaft extension length [mm].

X = Point of application of the radial force to the shaft collar [mm]



Axial Loads

L10h = 20.000 h (in accordance with ISO R 281-1) operating frequency 50 Hz; no external radial forces.

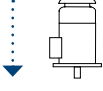
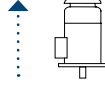
Mounting arrangement IM B3, IM B35

Frame size	 Maximum allowed Axial force [N]				 Maximum allowed Axial force [N]			
	2 poles	4 poles	6 poles	8 poles	2 poles	4 poles	6 poles	8 poles
71	275	350	410	460	275	350	410	460
80	450	550	650	730	450	550	650	730
90	485	610	720	810	485	610	720	810
100	670	850	980	1100	670	850	980	1100
112	990	1200	1450	1600	990	1200	1450	1600
132	1400	1800	2050	2300	1400	1800	2050	2300
160	1000	1200	1450	1650	2000	2500	2900	3300
180	950	1300	1500	1700	2000	2500	2900	3200
200	710	710	710	710	2650	3350	3850	4300
225	1750	2100	2500	2750	3000	3700	4300	4750
250	1700	2050	2000	2120	3400	4200	4800	5400
280	3250	4050	4700	5200	3250	4050	4700	5200
315 M	4000	4850	5600	6200	4000	4850	5600	6200
315 L	3240	3930	4530	- / -	3240	3930	4530	- / -
355 L	2000	6000	7000	8000	2000	6000	7000	8000
400 LA-LB	1850	6000	7100	- / 6900	1850	6000	7100	- / 6900
400 LC-LD	1000 / -	1630 / -	300	300	1000 / -	1630 / -	300	300
450 L	4200	7300	8300	4600	4200	7300	8300	4600

Mounting arrangement IM V1, IM V15

Frame size	 Maximum allowable axial force In downwards direction [N]				 Maximum allowable axial force In upwards direction [N]			
	2 poles	4 poles	6 poles	8 poles	2 poles	4 poles	6 poles	8 poles
71	330	440	560	640	360	480	600	680
80	540	720	850	980	590	780	930	680
90	550	730	880	1050	630	840	1000	1150
100	750	1050	1250	1400	900	1180	1400	1600
112	1150	1500	1800	2000	1300	1700	2000	2300
132	1600	2100	2500	2900	1950	2500	3000	3450
160	1730	2040	2470	2930	1270	1660	1880	2020
180	1650	1990	2340	2680	1300	1820	2060	2230
200	2190	2750	3140	3660	1170	1310	1430	1350
225	2380	2760	3330	3820	2370	3040	3470	3680
250	2700	3160	3540	4250	2410	3090	3260	3270
280	2130	2430	3100	3640	4370	5670	6300	6760
315 M	2170	1950	2150	2820	5830	7750	9050	9580
315 L	1350	1270	490	- / -	5850	7470	9590	- / -
355 L	3690	1880	300	300	160	14100	15800	17100
400 LA-LB	1350	300	300	- / 300	2450	14400	16900	- / 6900
400 LC-LD	1000 / -	300 / -	300	300	1000 / -	1630 / -	300	300
450 L	300	300	300	300	100	714	11100	13900

Protective treatment

External surfaces

The standard painting process consists of epoxy vinyl-polyurethane paint: of a thickness used to ensure an optimum environmental resistance. Standard finishing paint colour is RAL 5010. Other RAL and MUNSSELL colours are available on request.

The special painting process, consisting of epoxy vinyl paint followed by poly-acrylic paint, is available on request.

This process is particularly recommended for:

- environments where acids or basic liquids are present
- outdoor installations where salt is present
- marine applications
- environments where anhydride gases are present.

Corrosivity category	Process	Characteristics	Minimum Thickness
C1	Standard F96833	Base paint: epoxy vinyl paint	50 µm
C3	On request F96831	Base paint: epoxy vinyl paint Final Paint: polyacrylic paint	100 µm
C3-C4 Low	On request F96819	Base paint: epoxy vinyl paint + Final Paint: polyacrylic paint	160 µm
C4 High - C5 Industrial	On request F96826	Base paint: epoxy paint + Final Paint: polyacrylic paint	240 µm
C5 Marine	On request F96827	Base paint: epoxy paint + Final Paint: polyacrylic paint	320 µm

Internal Surfaces

All internal surfaces of motors from 160 frame size are tropicalized with an insulating enamel to prevent motor corrosion due to humidity and aggressive substances.

Balancing and vibration grades

Vibration grade	Mounting	63 < h < 132			160 < h < 280			H > 280		
		Displac. [µm]	Vel. [mm/s]	Acc. [m/s ²]	Displac. [µm]	Vel. [mm/s]	Acc. [m/s ²]	Displac. [µm]	Vel. [mm/s]	Acc. [m/s ²]
A reduced	Free	25	1.6	2.5	35	2.2	3.5	45	2.8	4.4
	Ridig	21	1.3	2.0	29	1.8	2.8	37	2.3	3.6
B special	Free	11	0.7	1.1	18	1.1	1.7	29	1.8	2.8
	Ridig	-*	-*	-*	14	0.9	1.4	24	1.5	2.4

The motors are dynamically balanced with a half key applied to the shaft extension in accordance with standard IEC 60034-14 to vibration severity grade normal (A) in standard construction.

The table indicates the maximum vibration grades with respect to the varying shaft heights. Motors can be supplied with either a special (B) vibration level on request.

The instrumentation can have a measurement tolerance of 10%.

Terminal box

Motors are provided with the terminal box placed on the top and the cable entry on the right side.

Frame size	Terminal thread	Main entrance	Auxiliary entrance
71 - 80	M6	M25 x 1,5	M20 x 1,5
90 - 132	M6	M32 x 1,5	M20 x 1,5
160 - 200	M6	2 x M40 x 1,5	M20 x 1,5
225 - 250	M8	2 x M50 x 1,5	M20 x 1,5
280 - 315	M12	2 x M75 x 1,5	M20 x 1,5
355	M20	2 x M75 x 1,5	-
400 - 450	M20	2 x M75 x 1,5	-

Frame size 71 - 80

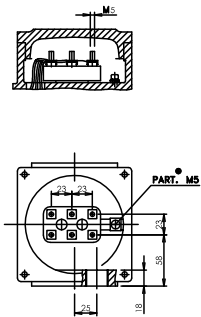

Frame size 90 - 132

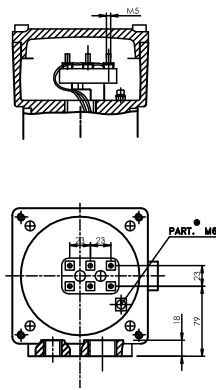

Frame size 160 - 200

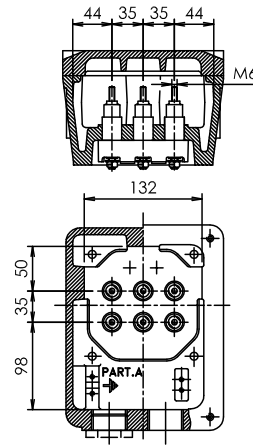

Frame size 225 - 250

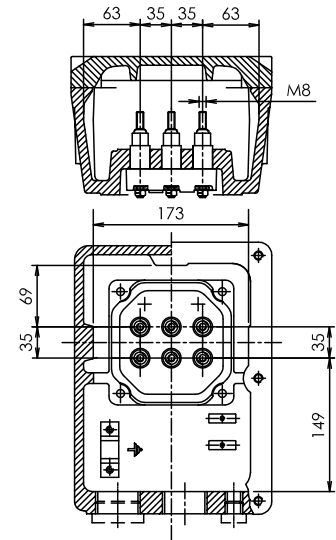

Frame size 280 - 315

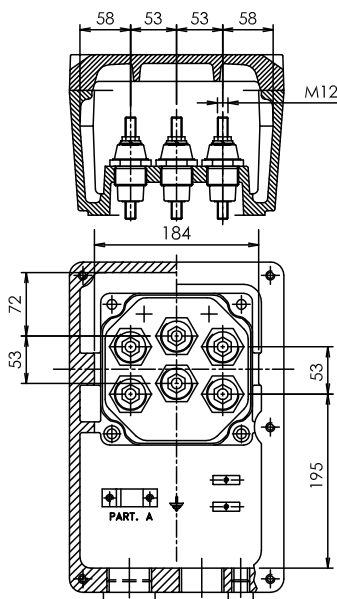

Frame size 355

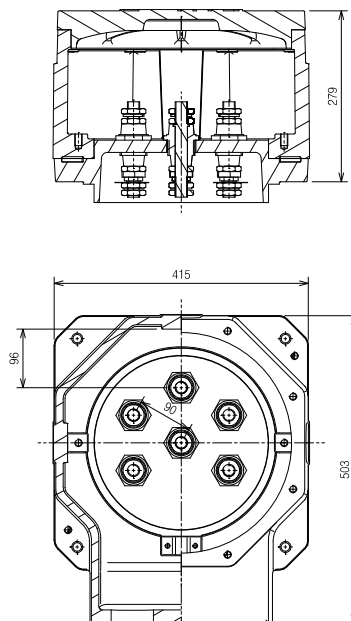

Frame size 400 - 450

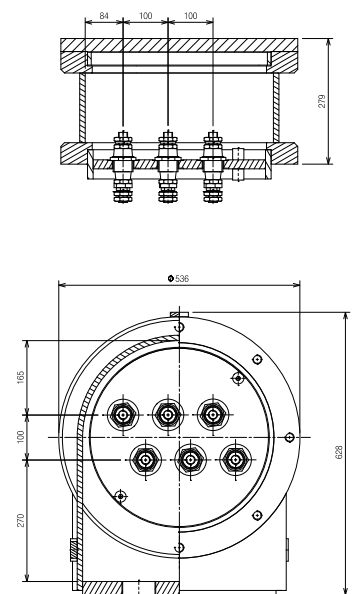

Motors for variable speed applications

A.C. motors designed for sinusoidal feeding voltage and constant feeding frequency can, under normal conditions, be used in variable speed applications by means of a frequency converter. Motors for variable speed applications are generally fed by the frequency converter by upholding the relationship U_n/f_n up to the speed correspondent to the nominal voltage and frequency and, for higher speeds, by increasing the frequency and keeping constant the nominal voltage value.

The performances of a motor fed by frequency converter depend on the cooling type: self-ventilated motors are suitable for use at loads with quadratic torque/speed shapes (typical case for pumps and fans).

When constant torque is required from low speeds, forced ventilation must be employed. Generally the motor type can be chosen referring to the following diagram by considering:

- the torque diagram of the motor
- the speed range
- the cooling type.

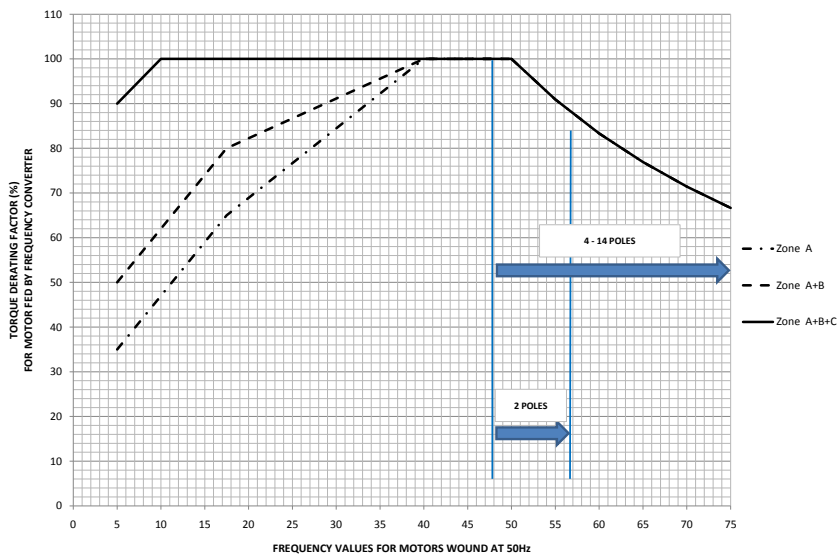

In both cases the resistant torque of the driven machine must be lower than the leading torque of the motor for the total running speed range.

The speed range is set from a minimum frequency F_{MIN} (typically around 5-10 Hz depending on the converter), and a maximum frequency F_{MAX} given by the speed limits of the rotating system and/or the reduction in torque.

Cooling Method IC 411	Poles	Frame size
Zone A + B	2 - 14	≥ 355
Zone A	6 - 8	≤ 315
Zone A + B	2 - 4	≤ 315

The use of the frequency converter requires some precautions regarding the voltage peaks and wave-fronts. The values of the peaks depend on the supply voltage of the motor feeding cable length.

According to different voltage levels, peak values and features of the insulation are based on the following table.

Frame size	$V_n \leq 500 \text{ V}$		$V_n \leq 690 \text{ V}$	
	Peak Voltage Limits	Features	Peak Voltage Limits	Features
160 ÷ 250	$V_{pk} \leq 800 \text{ V}$ Rise Time $\geq 1 \mu\text{s}$	Standard motor	$V_{pk} \leq 800 \text{ V}$ Rise Time $\geq 1 \mu\text{s}$	Standard insulation + dU/dt filters*
280 ÷ 315	$V_{pk} \leq 1000 \text{ V}$ Rise Time $\geq 1 \mu\text{s}$	Enhanced insulation	$V_{pk} \leq 1000 \text{ V}$ Rise Time $\geq 1 \mu\text{s}$	Standard insulation + dU/dt filters*
355 ÷ 450	$V_{pk} \leq 1350 \text{ V}$ Rise Time $\geq 1 \mu\text{s}$	Enhanced insulation	$V_{pk} \leq 2150 \text{ V}$ Rise Time $\geq 0,5 \mu\text{s}$ $V_{pk} \leq 1900 \text{ V}$ Rise Time $\geq 0,2 \mu\text{s}$	Superior insulation

* The filter depends on the characteristics of the converter and therefore any inquiries should be directed to the converter manufacturer.

Motors fed by frequency converter can be subject to voltages between the D-end and N-end bearing arrangements. This is due to the effects of the feeding system. The values of the aforementioned voltages depend on the characteristic of the frequency converter and on the dimensions of the motor itself. For motors from 315 frame size or those where the shaft peak voltage exceed 500 mV, Marelli Motori suggest to insulate on of the bearing arrangements of the motor. Normally this solution is applied to the N-end of the motor. These guidelines, coupled with the correct grounding of the operating system, motor and coupled machine, guarantee the best result.

Voltage and frequency

The motors described in this catalogue have nominal ratings and performances referred to the nominal voltage mentioned in the main nameplate, according to the Standard IEC 60034-1. This Standard classifies voltage and frequency variations in two different areas A and B as shown in the following figure.

Area A – The motor shall be capable of performing its primary function continuously, but need not comply fully with its performance at rated voltage and frequency and may exhibit some deviations.

Area B – In this area the motor shall be capable of performing its primary function, but may exhibit greater deviations from its performance at rated voltage and frequency than in zone A. Extended operation at the perimeter of zone B is not recommended.

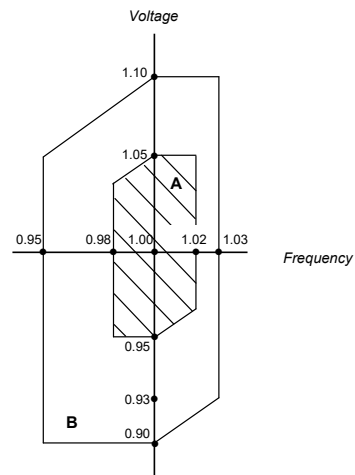

The motors can be wound for special voltage and frequency values, on request.

Deratings

Should the environmental conditions be different from the conditions given by IEC 60034-1 §6 standards (continuous duty S1, at 50 Hz for rated voltage, 40° ambient temperature, and an altitude up to 1000 m a.s.l.), the output ratings are obtained by applying the factors as per the following table.

Altitude (m)	Ambient Temperature (C°)						
	a.l.m.	30	35	40	45	50	55
1000	-	-	1,00	0,95	0,92	0,88	0,83
1500	-	1,00	0,97	0,92	0,90	0,85	0,82
2000	1,00	0,95	0,94	0,90	0,87	0,83	0,80
2500	0,96	0,93	0,90	0,88	0,85	0,81	0,77
3000	0,92	0,90	0,86	0,85	0,82	0,78	0,75
3500	0,90	0,88	0,82	0,81	0,80	0,76	0,73
4000	0,86	0,84	0,80	0,78	0,77	0,73	0,70
4500	0,82	0,80	0,76	0,74	0,72	0,70	0,67
5000	0,78	0,75	0,71	0,69	0,67	0,65	0,62

Tolerances

Mechanical

A selection of tolerances, in accordance with IEC 60072-1, are indicated in the following table. The second shaft extension is built only on request.

Part	Dimension	Tolerance
Shaft Extension	D-DA	from 14 to 28mm k6 / from 55 to 80mm m6
Key	F-FA	h9
Flange concentricity	N	up to framesize 132 j6 / greater than 132 h6
Shaft height	H	up to framesize 250 – 0.5mm / greater than 250 – 1mm

Electrical

Electrical tolerances in accordance with standard IEC 60034-1.

Efficiency	-15% of (1 - η) for $P_{nom} \leq 150$ kW -10% of (1 - η) for $P_{nom} > 150$ kW
Power factor	-1/6 (1 - $\cos \varphi$) Minimum absolute value 0.02 Maximum absolute value 0.07
Slip	$\pm 20\%$ for $P_{nom} \geq 1$ kW $\pm 30\%$ for $P_{nom} < 1$ kW
Locked rotor current	+20% of the current
Locked rotor torque	-15% +20% of rated torque
Run up torque	-10% of rated torque >1,5Mn
Breakdown torque	-10% of the value
Moment of inertia	$\pm 10\%$
Noise	+3 dB (A)
Vibration	+10% of the guaranteed class

Routine, type and special tests

Marelli Motori has a state of the art test facility in Arzignano capable of testing motors and generators in their original mounting arrangement (vertical and horizontal).

Testing can be conducted at 50/60 Hz and variable speed as the facility is provided with a large power – high frequency AFE inverter (regenerative).

Testing is carried out in compliance with all major international standards (IEC, IEEE), customer specifications, marine/navy and ATEX rules.

Options

Code	Description	71÷80	90÷132	160	180	200	225	250	280	315	355÷500
100	Insulation class H	O	O	O	O	O	O	O	O	O	O
107	Tropicalization	O	O	S	S	S	S	S	S	S	S
108	Anticondensation heaters, with terminals in main terminal box	NA	O	O	O	O	O	O	O	O	NA
109	Anticondensation heaters, with terminals in auxiliary terminal box	NA	O	O	O	O	O	O	O	O	O
111	PTC thermistors with terminals in main terminal box	O	S	S	S	S	S	S	S	S	O
114	PTC thermistors with terminals in auxiliary terminal box	NA	O	O	O	O	O	O	O	O	S
112	PT100 thermo detectors with terminals in main terminal box	NA	O	O	O	O	O	O	O	O	NA
115	PT100 thermo detectors with terminals in auxiliary terminal box	NA	O	O	O	O	O	O	O	O	O
122	Thermo detectors PT100 in bearings	NA	NA	O	O	O	O	O	O	O	O
125	Protection degree IP56	O	O	O	O	O	O	O	O	O	O
126	Protection degree IP65	O	O	O	O	O	O	O	O	O	NA
127	Second shaft end	O	O	O	O	O	O	O	O	O	O
128	Sealed bearings	O	O	O	O	O	O	O	O	O	O
129	Roller bearings on D-end	NA	NA	O	O	O	O	O	S*	S*	S
130	Oil seal	S	S	O	O	O	O	O	O	O	O
131	Drainage hole with tap	NA	NA	O	O	O	O	O	O	S	S
132	Vibration level A	S	S	S	S	S	S	S	S	S	S
133	Vibration level B	O	O	O	O	O	O	O	O	O	O
134	Metallic Fan	NA	NA	O	O	O	O	O	O	O	S
136	D-end special shaft extension	O	O	O	O	O	O	O	O	O	O
137	Low temperature duty	O	O	O	O	O	O	O	O	O	O
138	D-end and N-end grease nipples	NA	NA	O	O	O	O	O	S	S	S
139	Arrangement for SPM (Shock Pulse Measurement)	NA	NA	O	O	O	O	O	O	O	S
154	Arrangement for tachometer	NA	NA	O	O	O	O	O	O	O	O
159	Complete with tachometer	NA	NA	O	O	O	O	O	O	O	O
160	Arrangement for encoder standard type	NA	NA	O	O	O	O	O	O	O	O
161	Complete with encoder standard type	NA	NA	O	O	O	O	O	O	O	O
170	Anti rain canopy for IM V1	S	S	S	S	S	S	S	S	S	S
174	Locked D-end bearing	O	O	O	O	O	O	O	S*	S*	S
175	Insulated ND-end bearing	NA	NA	NA	NA	NA	NA	NA	O	O	O
177	Forced ventilation	NA	NA	O	O	O	O	O	O	O	O
178	Enhanced insulation system for Inverter application	NA	NA	NA	NA	NA	NA	NA	O	O	O
179	Special fan for reduced noise level	NA	NA	O	O	O	O	O	O	O	O
304	Special voltage and/or frequency	O	O	O	O	O	O	O	O	O	O
312	Special cable entry	O	O	O	O	O	O	O	O	O	O
313	Cable glands	O	O	O	O	O	O	O	O	O	O
919	Non standard RAL paint colour	O	O	O	O	O	O	O	O	O	O
930	Special painting process for aggressive environments	O	O	O	O	O	O	O	O	O	O

NA Not available O Optional
 S Standard * Optional for 2 poles



Motor applications

Product map	41
Motor range	41
Selection table	42
• TEFC Non sparking motors:	
Ex nA II C T3 Gc: B5N - B5L	43
• TEFC Flameproof motors:	
Ex d/(de) II B T4 Gb: D5H - D5L - D6C - D5C - D5F - D6X - D5X - D5S	46
Ex d/(de) I Mb: D5T - D5U	49
Ex d/(de) II C T4 Gb: D6K - D5K - D5R - D5V - D5Y - D6Y	51

Product map

Product		Centrifugal & reciprocating compressors	Heat exchangers and blowers	Pumps	Extruders and expanders	Conveyor system	Mixers	Mills	Cranes
TEFC Non sparking Ex nA II C T3 Gc	B5N - B5L	•	•	•	•	•	•	•	•
TEFC Flameproof Ex d / de II B T4 Gb	D5H - D5L D6C - D5C - D5F D6X - D5X - D5S	•	•	•	•	•	•	•	•
TEFC Flameproof Ex d / de I Mb	D5T - D5U	•	•	•	•	•	•	•	•
TEFC Flameproof Ex d / de II C T4 Gb	D6K - D5K D5R - D5V D5Y - D6Y	•	•	•	•	•	•	•	•

Motor range

Key

- TEFC - Non sparking motors - Ex nA II C T3 Gc - LV/MV
- TEFC - Flameproof motors - Ex d/(de) II B T4 Gb - MV
- TEFC - Flameproof motors - Ex d/(de) II B T4 Gb - LV
- TEFC - Flameproof motors - Ex d/(de) I Mb - LV
- TEFC - Flameproof motors - Ex d/(de) II C T4 Gb - LV

Motor model

- B5N - B5L**
- D5H - D5L**
- D6C - D5C - D5F - D6X - D5X - D5S**
- D5T - D5U**
- D6K - D5K - D5R - D5Y - D6Y - D5V**

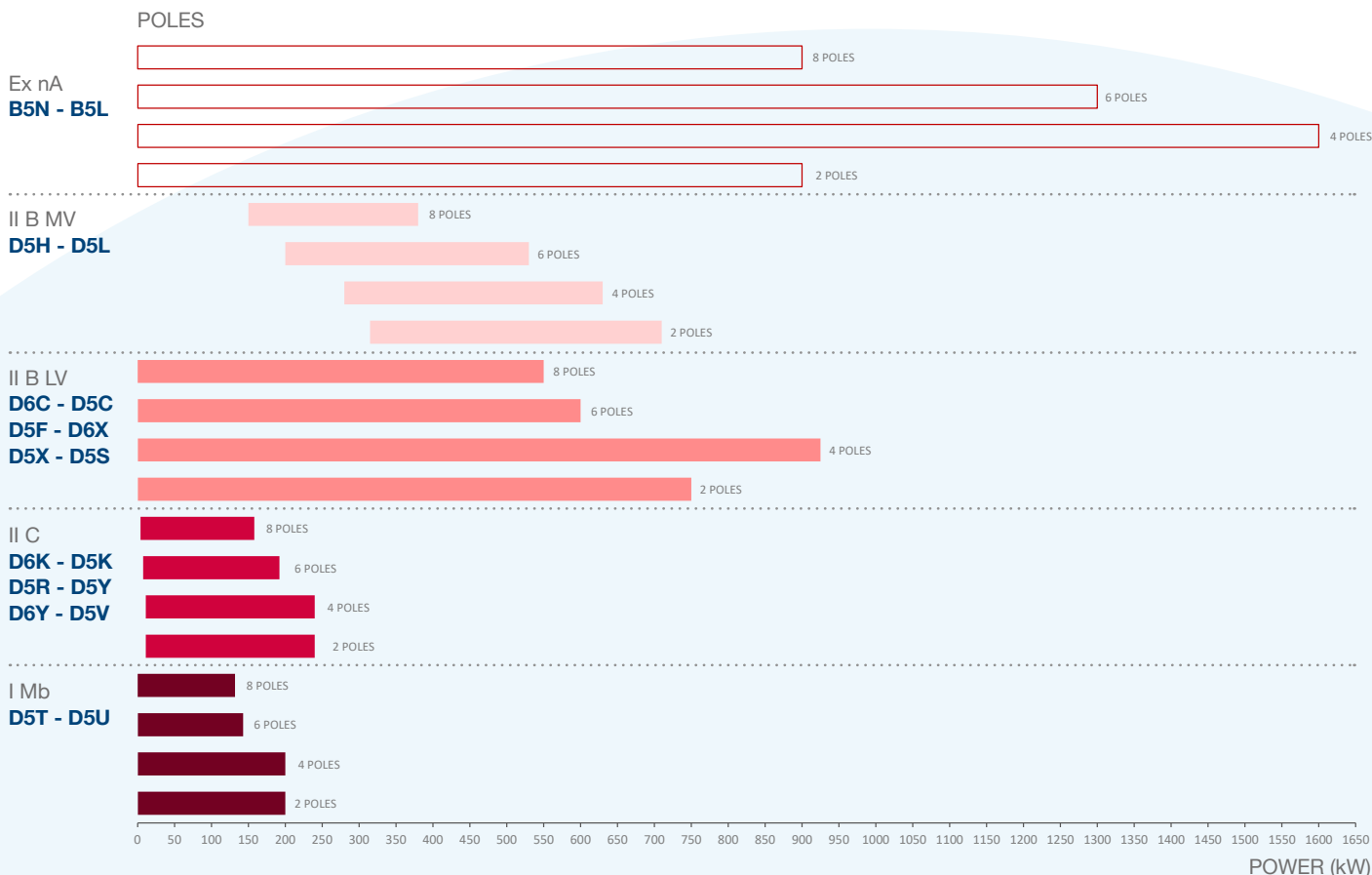

Selection table

Group	Category atmosphere	Type of protection	Sub Group	Temperature class	EPL	Voltage	Series	Size (mm)	Polarity	Supply	Product page	
I	M2	Ex d	I	-	Mb	LV	D5T	160 ÷ 315	S	M/I	pg 53	
		Ex de				LV	D5U	160 ÷ 315	D	M/I		
II	2G	Ex d	II B	T3 T4 T5	Gb	LV	D6C	71 ÷ 132	S	M/I*	pg 50	
						LV	D5C	160 ÷ 450	S	M		
				T3 T4	Gb	LV	D5F	160 ÷ 450	S	I		
						LV	D5D	160 ÷ 450	D	M		
						MV	D5H	355 ÷ 450	S	M		
						LV	D6K	71 ÷ 132	S	M/I*		
		T3 T4 T5	Gb	LV	D5K	160 ÷ 315	S/D	M	pg 56			
				LV	D5R	160 ÷ 315	S	I				
				LV	D6X	71 ÷ 132	S	M/I*				
		Ex de	II B	T3 T4 T5	Gb	LV	D5X	160 ÷ 450	S	M	pg 50	
						LV	D5S	160 ÷ 450	S	I		
				T3 T4	Gb	LV	D5E	160 ÷ 450	D	M		
						MV	D5L	355 ÷ 450	S	M		
						LV	D6Y	71 ÷ 132	S	M/I*		
						LV	D5Y	160 ÷ 315	S/D	M		pg 56
		LV	D5V	160 ÷ 315	S	I						
		3G	Ex nA	II C	T3	Gc	LV	B5N	71 ÷ 132	S	M/I	pg 47
							LV	A5N	160 ÷ 280	S	M/I	
LV	B5N						160 ÷ 500	S	M/I			
MV	B5L						355 ÷ 500	S	M			



Non sparking motors: Ex nA IIC T3 Gc



Model LV	B5N
Model MV	B5L
Atex Protection	Ex nA II C T3 Gc
Power	Up to 1.600 kW
Voltages	Up to 6.600 V
Frame LV	71 ÷ 500
Frame MV	355 ÷ 500
Pole	2, 4, 6, and 8
Cooling	IC 411 on request IC 416
IP	IP 55 / 56 / 65
Main applications	Centrifugal & reciprocating compressor, Heat exchangers and blowers, Pumps, Extruders and expanders, conveyor systems, Mixers, Mills, Cranes.

	2 POLES	4 POLES	6 POLES	8 POLES
kW	900	1.600	1.300	900

Certificates and testing

Certificate

Motors from 160 to 315 frame size are certified by TÜV NORD.
Ex nA according to IEC/EN 60079-15 and ATEX directive 2014/35/EU.

Test and survey

See complete list on Test room chapter.

Main components

Housing Frame is made in cast iron.
(EN 1561-GJL-200)

Shield Made in cast-iron (EN 1561 – GJL 200)

Shaft
General data
Made in carbon steel (EN 10083 – 2 C45)
Shaft design
Cylindrical shaft with key.

Main terminal box Mounted on top.
Made in cast iron. (EN 1561 – GJL 200)

Fan

Frame	71 ÷ 280	315		355 ÷ 450	
Pole	2 ÷ 8	2 ÷ 6	8	2	4 ÷ 6
Material	Thermoplastic reinforced with glass fibres		Metallic	Polyamide	Aluminium alloy

Construction

Enclosure TEFC – Totally Enclosed Fan Cooled Motors.

Cooling system IC 411 as per IEC60034-6.
Totally enclosed standard motor, frame surface cooled with fan
4: frame surface cooled
1: self circulation of primary coolant
1: self circulation of secondary coolant
On request for variable speed application an external ventilation unit can be supplied to get the IC416 cooling type.

Degree of protection IP 55 as per IEC60034-5. (Available up to IP 65)



Technical data

Stator/Rotor core

Laminated and enamel-insulated on both sides to minimise eddy-current losses. The stator winding is made in flat copper or round copper wire depending on the machine size.

The completely wound stator pack with housing is thereby impregnated in an epoxy-resin VPI.

The subsequent heat treatment hardens the resin.

Rotor

Short circuit rotor type.

Depending on machine size, the rotor construction is usually a solid shaft type.

The rotor winding can be either a pressure die cast aluminum or a copper bar construction.

Bearing

General data

Motors are normally fitted with single-row deep groove ball bearings.

- Up to 132 frame size bearings are lubricated for life.
- Up to 250 frame size motors are supplied with prelubricated ball bearings without grease nipples.
- From 280 frame size and above motors are supplied with regreasable bearings and greasing nipples on both ends.
- From 355 frame size SPM nipples for bearing vibration monitoring are delivered as standard both at N and D end.

The motor bearings are designed according to the principle that the locating bearings are on the D end side and the floating bearings on the ND end side.

Bearings are first greased in the factory with lithium base grease.

The used grease is removed through a valve locked in the outer bearing cover. Sleeve bearings available as an option.

Impregnation system

Stator is VPI treated with an unsaturated polyester amide resin which is polymerisation in an oven.

Insulation system

Stator: F class insulated with a synthetic enamel.

(H class insulation available on request)

Protective treatments

Specific Oil&gas treatment.

Optional features

- Reinforced insulation suitable for frequency converter application
- dual / multiple winding configuration
- special shaft end on both sides
- increase protection degree up to IP 56 / 65
- encoder
- vibration sensors
- special frame design to suite the application
- insulated bearings design
- other options available on request.

Flameproof motors: Ex d/(de) II B T4 Gb



Model LV d	D6C - D5C - D5F
Model MV d	D5H
Model LV de	D6X - D5X - D5S
Model MV de	D5L
Atex Protection	Ex d/(de) IIB T4 Gb
Power	Up to 925 kW
Voltages	Up to 6.600 V
Frame LV	71 ÷ 450
Frame MV	355 ÷ 450
Pole	2, 4, 6, and 8
Cooling	IC 411 on request IC 416
IP	IP 55 / 56 / 65
Main applications	Centrifugal & reciprocating compressor, Heat exchangers and blowers, Pumps, Extruders and expanders, conveyor systems, Mixers, Mills, Cranes.

Motor series	Atex Protection	Starting	71 to 132 frame	160 to 315 frame	355 to 450 frame
LV series	Ex d IIB T4 Gb	DOL	D6C		D5C
		VFD			D5F
	Ex de IIB T4 Gb	DOL	D6X		D5X
		VFD			D5S
MV series	Ex d IIB T4 Gb	-	-	D5H	
	Ex de IIB T4 Gb	-	-	D5L	

	2 POLES	4 POLES	6 POLES	8 POLES
kW	750	925	660	550



Certificates and testing

Certificate Motors from 71 to 132 frame size are certified by BVI.
Motors from 160 to 450 frame size are certified by CESI.
Ex d/(de) according to IEC/EN 60079-1/60079-7 and ATEX directive 2014/35/EU.

Test and survey See complete list on Test room chapter.

Main components

Housing Frame is made in cast iron.
(EN 1561-GJL-200)

Shield Made in cast-iron (EN 1561 – GJL 200)

Shaft
General data
Made in carbon steel (EN 10083 – 2 C45)
Shaft design
Cylindrical shaft with key.

Main terminal box Mounted on top.
Made in cast iron. (EN 1561 – GJL 200)

Fan

Frame	71 ÷ 280	315	355 ÷ 450		
Pole	-	2 ÷ 6	8	2	4 ÷ 8
Material	Thermoplastic reinforced with glass fibres		Metallic	Polyamide	Aluminium alloy

Construction

Enclosure TEFC – Totally Enclosed Fan Cooled Motors.

Cooling system IC 411 as per IEC60034-6.
Totally enclosed standard motor, frame surface cooled with fan
4: frame surface cooled
1: self circulation of primary coolant
1: self circulation of secondary coolant
On request for variable speed application an external ventilation unit can be supplied to get the IC416 cooling type.

Degree of protection IP 55 as per IEC60034-5. (Available up to IP 65)

Technical data

Stator/Rotor core

Laminated and enamel-insulated on both sides to minimise eddy-current losses. The stator winding is made in flat copper or round copper wire depending on the machine size.

The completely wound stator pack with housing is thereby impregnated in an epoxy-resin VPI.

The subsequent heat treatment hardens the resin.

Rotor

Short circuit rotor type.

Depending on machine size, the rotor construction is usually a solid shaft type.

The rotor winding can be either a pressure die cast aluminum or a copper bar construction.

Bearing

General data

Motors are normally fitted with single-row deep groove ball bearings.

- Up to 132 frame size bearings are lubricated for life.
- Up to 250 frame size motors are supplied with prelubricated ball bearings without grease nipples.
- From 280 frame size and above motors are supplied with regreasable bearings and greasing nipples on both ends.
- From 355 frame size SPM nipples for bearing vibration monitoring are delivered as standard both at N and D end.

The motor bearings are designed according to the principle that the locating bearings are on the D end side and the floating bearings on the ND end side.

Bearings are first greased in the factory with lithium base grease.

The used grease is removed through a valve locked in the outer bearing cover.

Impregnation system

Stator is VPI treated with an unsaturated polyester amide resin which is polymerisation in an oven.

Insulation system

Stator: F class insulated with a synthetic enamel.
(H class insulation available on request)

Protective treatments

Specific Oil&gas treatment.

Vibrations

Mechanical vibrations correspond to the limits specified in EN 60034-14 and are certified by the test room.

Rating plate

Stainless steel, thickness 0,5 mm.

Optional features

- Reinforced insulation suitable for frequency converter application
- dual / multiple winding configuration
- special shaft end on both sides
- increase protection degree up to IP 56 / 65
- encoder
- vibration sensors
- special frame design to suite the application
- insulated bearings design
- other options available on request.



Flameproof motors: Ex d/(de) I Mb



Model Ex d	D5T
Model Ex de	D5U
Atex Protection	Ex d/ (de) I Mb
Power	Up to 240 kW
Voltages	Up to 690 V
Frame	160 ÷ 315
Pole	2, 4, 6, and 8
Cooling	IC 411 on request IC 416
IP	IP 55 / 56 / 65
Main applications	Centrifugal & reciprocating compressor, Heat exchangers and blowers, Pumps, Extruders and expanders, conveyor systems, Mixers, Mills, Cranes.

	2 POLES	4 POLES	6 POLES	8 POLES
kW	240	240	192	158

Certificates and testing

Certificate	Motors are certified by CESI. Ex d according to IEC/EN 60079-15 and ATEX directive 2014/35/EU.
Test and survey	See complete list on Test room chapter.

Main components

Housing	Frame is made in cast iron. (EN 1561-GJL-200)
Shield	Made in cast-iron (EN 1561 – GJL 200)
Shaft	General data Made in carbon steel (EN 10083 – 2 C45) Shaft design Cylindrical shaft with key.
Main terminal box	Mounted on top. Made in cast iron. (EN 1561 – GJL 200)

Fan	Frame	160 ÷ 280	315	
	Pole	-	2 ÷ 6	8
	Material	Thermoplastic reinforced with glass fibres		Metallic



Construction

Enclosure	TEFC – Totally Enclosed Fan Cooled Motors.
.....	
Cooling system	IC 411 as per IEC60034-6. Totally enclosed standard motor, frame surface cooled with fan 4: frame surface cooled 1: self circulation of primary coolant 1: self circulation of secondary coolant On request for variable speed application an external ventilation unit can be supplied to get the IC416 cooling type.
.....	
Degree of protection	IP 55 as per IEC60034-5. (Available up to IP 65)

Technical data

Stator/Rotor core	Laminated and enamel-insulated on both sides to minimise eddy-current losses. The stator winding is made in flat copper or round copper wire depending on the machine size. The completely wound stator pack with housing is thereby impregnated in an epoxy-resin VPI. The subsequent heat treatment hardens the resin.
.....	

Rotor	Short circuit rotor type. Depending on machine size, the rotor construction is usually a solid shaft type. The rotor winding can be either a pressure die cast aluminum or a copper bar construction.
.....	

Bearing	General data Motors are normally fitted with single-row deep groove ball bearings. <ul style="list-style-type: none"> • Up to 132 frame size bearings are lubricated for life. • Up to 250 frame size motors are supplied with prelubricated ball bearings without grease nipples. • From 280 frame size and above motors are supplied with regreasable bearings and greasing nipples on both ends. The motor bearings are designed according to the principle that the locating bearings are on the D end side and the floating bearings on the ND end side. Bearings are first greased in the factory with lithium base grease. The used grease is removed through a valve locked in the outer bearing cover.
.....	

Impregnation system	Stator is VPI treated with an unsaturated polyester amide resin which is polymerisation in an oven.
.....	

Insulation system	Stator: F class insulated with a synthetic enamel. (H class insulation available on request)
.....	

Protective treatments	Specific Oil&gas treatment.
.....	

Vibrations	Mechanical vibrations correspond to the limits specified in EN 60034-14 and are certified by the test room.
.....	

Rating plate	Stainless steel, thickness 0,5 mm.
---------------------	------------------------------------

Optional features	<ul style="list-style-type: none"> • Reinforced insulation suitable for frequency converter application • dual / multiple winding configuration • special shaft end on both sides • increase protection degree up to IP 56 / 65 • encoder • vibration sensors • special frame design to suite the application • insulated bearings design • other options available on request.
--------------------------	--



Flameproof motors: Ex d/(de) II C T4 Gb



Model Ex d	D6K - D5K - D5R
Model Ex de	D6Y - D5Y - D5V
Atex Protection	Ex d/ (de) IIC T4 Gb
Power	Up to 200 kW
Voltages	Up to 690 V
Frame	71 ÷ 315
Pole	2, 4, 6, and 8
Cooling	IC 411 on request IC 416
IP	IP 55 / 56 / 65
Main applications	Centrifugal & reciprocating compressor, Heat exchangers and blowers, Pumps, Extruders and expanders, conveyor systems, Mixers, Mills, Cranes.

Atex Protection	Starting	71 to 132 frame		160 to 450 frame	
Ex d IIC T4 Gb	DOL	D6K		D5K	
	VFD			D5R	
Ex de IIC T4 Gb	DOL	D6Y		D5Y	
	VFD			D5V	

	2 POLES	4 POLES	6 POLES	8 POLES
kW	200	200	143	132

Certificates and testing

Certificate

Motors from 71 to 132 frame size are certified by BVI.
 Motors from 160 to 315 frame size are certified by CESI.
 Ex d/(de) according to IEC/EN 60079-1/60079-7 and ATEX directive 2014/35/EU.

Test and survey

See complete list on Test room chapter.



Main components

Housing	Frame is made in steel. (EN 10025-S235 JR)
.....	
Shield	Made in cast-iron (EN 1561 – GJL 200 for D6 motors) Made in steel (EN 10025-S235 JR for small D5 motors)
.....	
Shaft	General data Made in carbon steel (EN 10083 – 2 C45) Shaft design Cylindrical shaft with key.
.....	
Main terminal box	Mounted on top. Made in cast iron. (EN 1561 – GJL 200)
.....	
Fan	Made in thermoplastic reinforced with glass

Construction

Enclosure	TEFC – Totally Enclosed Fan Cooled Motors.
.....	
Cooling system	IC 411 as per IEC60034-6. Totally enclosed standard motor, frame surface cooled with fan 4: frame surface cooled 1: self circulation of primary coolant 1: self circulation of secondary coolant On request for variable speed application an external ventilation unit can be supplied to get the IC416 cooling type.
.....	
Degree of protection	IP 55 as per IEC60034-5. (Available up to IP 65)



Technical data

Stator/Rotor core Laminated and enamel-insulated on both sides to minimise eddy-current losses. The stator winding is made in flat copper or round copper wire depending on the machine size.
 The completely wound stator pack with housing is thereby impregnated in an epoxy-resin VPI.
 The subsequent heat treatment hardens the resin.

Rotor Short circuit rotor type.
 Depending on machine size, the rotor construction is usually a solid shaft type. The rotor winding can be either a pressure die cast aluminum or a copper bar construction.

Bearing **General data**
 Motors are normally fitted with single-row deep groove ball bearings.

- Up to 132 frame size bearings are lubricated for life.
- From 160 frame size and above motors are supplied with regreasable bearings and greasing nipples on both ends.

The motor bearings are designed according to the principle that the locating bearings are on the D end side and the floating bearings on the ND end side.
 Bearings are first greased in the factory with lithium base grease.
 The used grease is removed through a valve locked in the outer bearing cover.

Impregnation system Stator is VPI treated with an unsaturated polyester amide resin which is polymerisation in an oven.

Insulation system Stator: F class insulated with a synthetic enamel.
 (H class insulation available on request)

Protective treatments Specific Oil&gas treatment.

Vibrations Mechanical vibrations correspond to the limits specified in EN 60034-14 and are certified by the test room.

Rating plate Stainless steel, thickness 0,5 mm.

- Optional features**
- Reinforced insulation suitable for frequency converter application
 - dual / multiple winding configuration
 - special shaft end on both sides
 - increase protection degree up to IP 56 / 65
 - encoder
 - vibration sensors
 - special frame design to suite the application
 - insulated bearings design
 - other options available on request.



Generator applications

Product map	55
Generator range	55
• ODP generators: MJH	56
• TEAAC generators: MJHV	60
• ODP generators: MJB	65
• TEAAC generators: MJV	69

Product map

Product	Power generation	Auxiliary generators	Emergency
ODP MJH	•	•	•
TEAAC MJHV	•	•	•
ODP MJB	•	•	•
TEAAC MJV	•	•	•

Generator range

Key

- ODP - Open drip proof
- ◐ TEAAC - Totally Enclosed Air to Air Cooled
- ◑ ODP - Open drip proof
- TEAAC - Totally Enclosed Air to Air Cooled

Generator model

- MJH**
- MJHV**
- MJB**
- MJV**

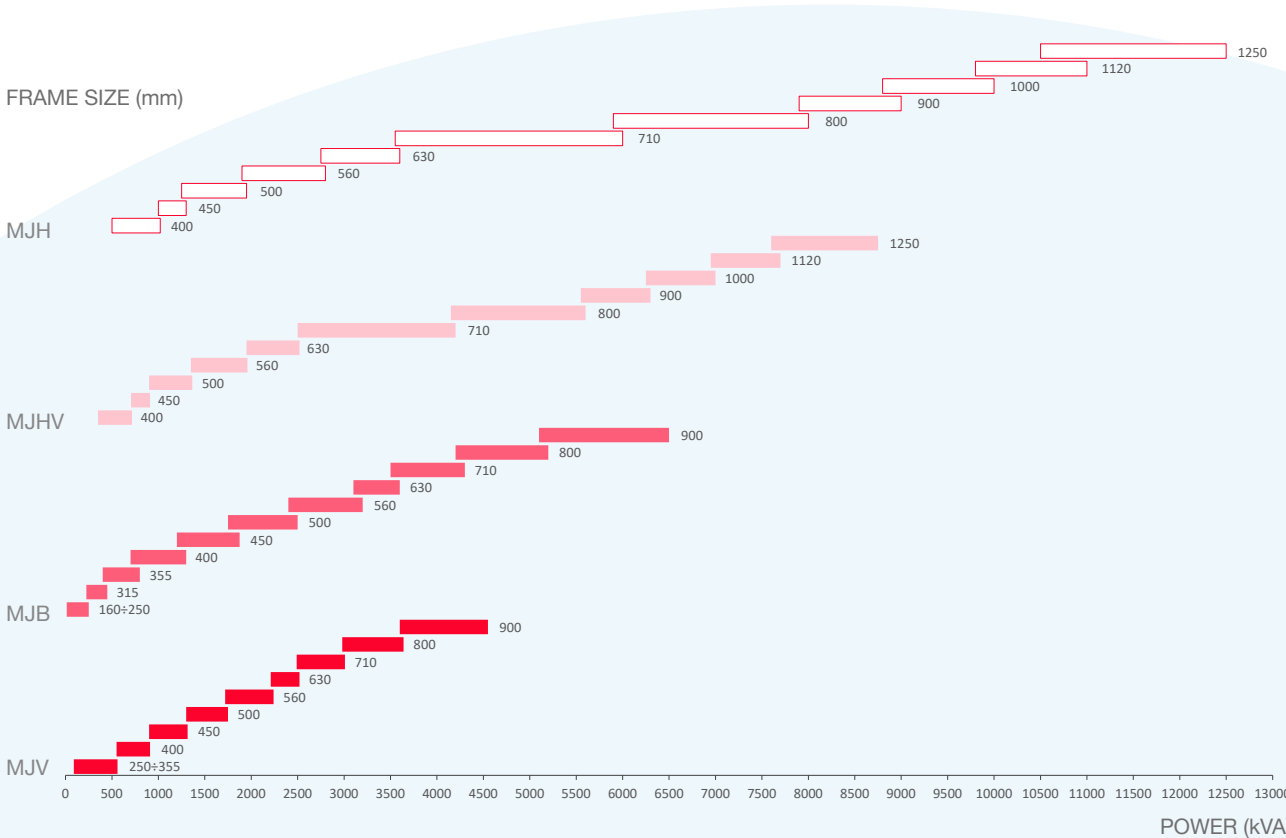



ODP generators: MJH

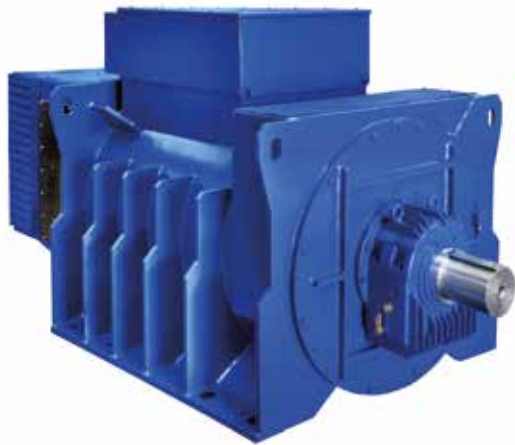

Model	MJH
Power	Up to 12.500 kVA
Voltages	Up to 15.000 V
Frame	400 ÷ 1.250
Pole	4, 6, 8, 10 and 12 (over contact MM)
Cooling	IC 01
IP	IP 23. Available up to IP 44 with filters
Main applications	Power generation, auxiliary generators, emergency

	4 POLES	6 POLES	8 POLES	10 POLES	12 POLES
kVA	10.000	12.500	12.500	12.500	10.000

Certificates and testing

Applicable standards

Generators are designed in compliance with:
IEC EN 60034 - 1
BS 4999 - 5000
VDE 0530
NF 51 - 100
NF 51 - 111
OVE M - 10
NEMA MG 1.32
Generators conform to EU rules.
UL/CSA certifications available on request.
Adherence to ISO 8528 group G performance classes.

Test

See complete list on Test room chapter.

Main components

Housing

Rigid frame, rugged welded steel fabrication (EN 10025 - S235 JR).
Frame is provided with side ribs to increase the strength.
Marelli Generators for continuous duty operation are designed to meet vibration levels per IEC 60034-14, ISO 10816-1 and BS 5000-3.

Shield

Made of spheroidal graphite cast-iron (EN 1563) or grey cast-iron (EN 1561) up to 630 frame size.
Made of structural steel (EN 10025 - S235 JR) above.

Shaft

General data

Made in carbon steel and obtained by lamination (EN 10083-2 C40-TN). Shaft is obtained by forging from 290 mm diameter and above.
The shaft is tested to ensure defect-free performance.

Shaft design

Double bearing generator: cylindrical shaft with key.

Main terminal box Mounted on top.
Made of formable steels EN 10130.

Fan Made of aluminum alloy (EN 1706) or structural steel (EN 10025 – S235 JR) depending upon application requirements.

Construction

Enclosure ODP - Open Drip Proof

Cooling system IC 01 as per IEC60034-6

Degree of protection IP 23 as per IEC60034-5. Available up to IP 44 with filters.

Mounting Horizontal - IM 1001 or IM 1101 as per IEC 60034-7.
Other mounting available on request.

Technical data

Stator/Rotor core Laminated and enamel-insulated on both sides to minimise eddy-current losses.

Rotor Salient pole type.
Made by copper flat wire.
H class insulated with enamel coating.
Winding retaining by pass-through bars of high quality steel.
Rotating rectifier: Graetz diode bridge with 6 diodes.
Rotors are dynamically balanced with a half key applied to the shaft extension in accordance with IEC 60034-14 to vibration grade normal A.
Special vibration level constructions are available.

Bearing

General data

Single or double antifriction bearing grease lubricated (ball or roller type) or oil lubricated sleeve bearing.

The theoretical lifetime of bearings, L10h according to ISO 281/1 standard, of standard horizontal construction generators, without external forces (radial and / or axial) is in excess of 50.000 hours. On request, the lifetime of bearings, L10h can be in excess of 100.000 hours.

Locating bearings are on the D end side and floating bearings on the ND end side.

Bearing selection

Antifriction bearings up to 800 frame size included.

Sleeve bearings from 900 frame size included (available for smaller frame sizes)

Regreasing system:

Up to 400 frame size:

- D-end bearing is fitted with inner bearing cap and with grease nipple
 - ND-end bearing is prelubricated with inner bearing cap and without grease nipple
- 450 frame size and above: both bearings are fitted with grease nipple.



Bearing insulation

ND end bearing can be insulated to prevent any harmful circulating current from passing through the bearing surfaces.

Insulated antifriction bearings in standard configuration:

- 4, 6 poles: insulated ND end bearing from 630 frame size
- 8 poles: insulated bearing from 400 frame size
- 10 poles: insulated bearing from 500 frame size

All ND end sleeve bearings are insulated as standard.

Impregnation system

Stator and rotor are VPI treated with an unsaturated polyester amide resin which is polymerized in an oven.

Insulation system

Stator: F class insulated with a synthetic enamel
Rotor: H class insulated with a synthetic enamel
(class F available on request)

Protective treatments

Specific Oil & Gas treatment.
Epoxivinilic and polyacrylic. Total minimum thickness 120 micromillimeters.
Epoxivinilic: Epoxy two component products, with vinyl change
Polyacrylic: Two components polyurethane product formulated with unmodified hydroxyl acrylic resin.

Operating conditions

Overloads

During continuous duty (S1), the following overloads are allowed:
10% for 1 hour
15% for 10 minutes
30% for 4 minutes
50% for 2 minutes
These overloads must be occasional and followed by 1 hour of running at normal load or less.

Parallel operations

All generators are provided with an amply sized damper cage and are suitable for parallel operations with other generators, when equipped with the paralleling unit. A power factor regulator (to work in parallel with the main) is available on request.

Transient performance

All generators can be designed to meet specific reactance values ($x'd$ and $x''d$). Values can be confirmed by contacting Marelli Motori.

Three phase short circuit current

All generators equipped with an overboosting device ensure a three phase short circuit current (I_{cc}) higher than 3 times the rated current (I_n): $I_{cc} > 300\% I_n$

Radio interference

All generators are equipped with Class B Group 1 radio interference filters as defined by EN 55011.

THD (Total Harmonic Distortion)

The no-load voltage wave form is sinusoidal with THD content less than 2%.

Vibrations

Vibration level is in accordance with ISO 10816.
Measurement, evaluation and limits of vibration severity are in accordance with IEC 60034-14.

Auxiliary devices

AVR

Automatic voltage regulator mounted on board.

Size	Type
400 - 450	MEC 20 analog/ digital
500 - 560	M40FA610A analog
630 - 710	M63FA310A analog
800 - 1250	MEC 100 digital

Digital AVR available for all sizes on request.

Overboosting device

	Size	Type
Medium voltage	All	CT + Overboosting device
High voltage	All	PMG

PMG available for all sizes on request.

Space heaters

Heaters installed at ND-end side.

Size	Power (W)
400 - 560	400
630 - 710	600
800 - 900	800
1000	1000
1120	1200
1250	1400

RTD - PT100

RTD devices in standard configuration:

- 1+1 RTD on each phase of stator winding
- 1 RTD on each bearing

Terminals in auxiliary terminal box.

Other configurations available:

- DUPLEX type
- RTD for inlet / outlet air

Optional features

- Flanged shaft for direct coupling with engine flywheel (in case of single bearing solution)
- neutral point terminals in separate terminal box
- dedicated current transformer installed on neutral point (differential protection and measurement)
- increase protection degree up to IP 44 with filters
- dedicated lubrication unit for sleeve bearing solution
- lifted feet to couple the generator with engine on existing baseframe
- redundant rotating rectifier with 12 diodes
- insulated bearing and earthing brush
- AVR supplied loose
- automatic power factor control (analog type or included into digital regulation)
- digital AVR MEC100 for frame 250 – 710 (supplied loose)
- digital AVR MEC100D with diode failure monitoring
- other digital AVR available on request.
- redundant AVR system
- excitation/overboosting PMG mounted generator
- arrangement for earthing rotor fault protection 64R
- other options available on request.

TEAAC generators: MJHV



Model	MJHV
Power	Up to 8.750 kVA
Voltages	Up to 15.000 V
Frame	400 ÷ 1250
Pole	4, 6, 8, 10 and 12 (over contact MM)
Cooling	IC 611
IP	IP 55. Available up to IP 56
Main applications	Power generation, auxiliary generators and emergency

	4 POLES	6 POLES	8 POLES	10 POLES	12 POLES
kVA	7.000	8.750	8.750	8.750	7.000

Certificates and testing

Applicable standards

Generators are designed in compliance with:

IEC EN 60034 - 1

BS 4999 - 5000

VDE 0530

NF 51 - 100

NF 51 - 111

OVE M - 10

NEMA MG 1.32

Generators conform to EU rules.

UL/CSA certifications available on request.

Adherence to ISO 8528 group G performance classes.

Test

See complete list on Test room chapter.

Main components

Housing	Rigid frame, rugged welded steel fabrication (EN 10025 - S235 JR). Frame is provided with side ribs to increase strength. Marelli Generators for continuous duty operation are designed to meet vibration levels per IEC 60034-14, ISO 10816-1 and BS 5000-3.
.....	
Shield	Made of spheroidal graphite cast-iron (EN 1563) or grey cast-iron (EN 1561) up to 630 frame size. Made of structural steel (EN 10025 – S235 JR) above.
.....	
Shaft	<p>General data</p> <p>Made in carbon steel and obtained by lamination (EN 10083 – 2 C40 – TN). Shaft is obtained by forging from 290 mm diameter and above. The shaft is tested by the manufacturer to ensure it is defect-free.</p> <p>Shaft design</p> <p>Double bearing generator: cylindrical shaft with key.</p>
.....	
Main terminal box	Mounted on side (right or left will be selected). Made of formable steels EN 10130.
.....	
Fan	Made of aluminum alloy (EN 1706) or structural steel (EN 10025 – S235 JR) depending on application requirements.
.....	
Internal fan	Made of structural steel (EN 10025 - 5235 JR)
.....	
Heat Exchanger	<p>Construction</p> <p>Mounted on top of alternator. Tube made of P - AlMgSi UNI 3569 Housing: EN 10025 - 5235JR</p>

Construction

Enclosure	TEAAC – Totally Enclosed Air to Air Cooled
.....	
Cooling system	IC 611 as per IEC60034-6. Primary fluid (air) driven by a second fan (internal fan) mounted on shaft at ND end side. Internal air is flowing by a fan mounted on the shaft of the generator at the driven side.
.....	
Operating temperature	Up to 60° C ambient temperature (over contact Marelli Motori)
.....	
Degree of protection	IP 55 as per IEC60034-5. Other protection degree available on request.
.....	
Mounting	Horizontal - IM 1001 or IM 1101 as per IEC 60034-7. Other mounting available on request.



Technical data

Stator/Rotor core	Laminated and enamel-insulated on both sides to minimise eddy-current losses
.....	
Rotor	Salient pole type. Made by copper flat wire. H class insulated with enamel coating. Winding retaining by pass-through bars of high quality steel. Rotating rectifier: Graetz diode bridge with 6 diodes. Rotors are dynamically balanced with a half key applied to the shaft extension in accordance with IEC 60034-14 to vibration grade normal A. Special vibration level construction are available.
.....	
Bearing	<p>General data Single or double antifriction bearing grease lubricated (ball or roller type) or oil lubricated sleeve bearing. The theoretical lifetime of bearings, L10h according to ISO 281/1 standard, of standard horizontal construction generators, without external forces (radial and / or axial) is in excess of 50.000 hours. On request, the lifetime of bearings, L10h can be in excess of 100.000 hours. Locating bearings are on the D end side and floating bearings on the ND end side.</p> <p>Bearing selection Antifriction bearings up to 800 frame size included. Sleeve bearings from 900 frame size included (available for smaller frame sizes).</p> <p>Regreasing system: Up to 400 frame size:</p> <ul style="list-style-type: none"> • D-end bearing is fitted with inner bearing cap and with grease nipple • ND-end bearing is prelubricated with inner bearing cap and without grease nipple <p>450 frame size and above: both bearings are fitted with grease nipple.</p> <p>Bearing insulation ND end bearing can be insulated to prevent any harmful circulating current from passing through the bearing surfaces. Insulated antifriction bearings in standard configuration:</p> <ul style="list-style-type: none"> • 4, 6 poles: insulated ND end bearing from 630 frame size • 8 poles: insulated bearing from 400 frame size • 10 poles: insulated bearing from 500 frame size <p>All ND end sleeve bearings are insulated as standard.</p>
.....	
Impregnation system	Stator and rotor are VPI treated with an unsaturated polyester amide resin which is polymerised in an oven.
.....	
Insulation system	Stator: F class insulated with a synthetic enamel Rotor: H class insulated with a synthetic enamel
.....	
Protective treatments	Specific Oil&gas treatment. Epoxivinilic and polyacrylic. Total minimum thickness 120 micromillimeters. Epoxivinilic: Epoxy two component products, with vinyl change Polyacrylic: Two components polyurethane product formulated with unmodified hydroxyl acrylic resin.

Operating conditions

Overloads	<p>During continuous duty (S1), the following overloads are allowed:</p> <ul style="list-style-type: none"> 10% for 1 hour 15% for 10 minutes 30% for 4 minutes 50% for 2 minutes <p>These overloads must be occasional and followed by one hour of running at normal load or less.</p>
Parallel operations	<p>All generators are provided with a amply sized damper cage and are suitable for parallel operations with other generators, when equipped with the paralleling unit. A power factor regulator (to work in parallel with the main) is available on request.</p>
Transient performance	<p>All generators can be designed to meet specific reactance values ($x'd$ and $x''d$). Values can be confirmed by contacting Marelli Motori.</p>
Three phase short circuit current	<p>All generators equipped with overboosting device ensure a three phase short circuit current (I_{cc}) higher than three times the rated current (I_n):</p> $I_{cc} > 300\% I_n$
Radio interference	<p>All generators are equipped with Class B Group 1 radio interference filters as defined by EN 55011.</p>
THD (Total Harmonic Distortion)	<p>The no-load voltage wave form is sinusoidal with THD content less than 2%.</p>
Vibrations	<p>Vibration level is in accordance with ISO 10816. Measurement, evaluation and limits of vibration severity are in accordance with IEC 60034-14.</p>



Auxiliary devices

AVR Automatic voltage regulator mounted on board.

Size	Type
400 - 450	MEC 20 analog/ digital
500 - 560	M40FA610A analog
630 - 710	M63FA310A analog
800 - 1.250	MEC 100 digital

Digital AVR available for all sizes on request.

Overboosting device

Size	Type
Medium voltage	All CT + Overboosting device
High voltage	All PMG

PMG available for all sizes on request.

Space heaters

Size	Power (W)
400 - 560	400
630 - 710	600
800 - 900	800
1.000	1.000
1.120	1.200
1.250	1.400

Heaters installed at ND end side.

- RTD - PT100**
- RTD devices in standard configuration:
- 1+1 RTD on each phase of stator winding
 - 1 RTD on each bearing
- Terminals in auxiliary terminal box.
- Other configurations available:
- DUPLEX type
 - RTD for inlet / outlet air
 - RTD into oil tank for sleeve bearing

Optional features

- Flanged shaft for direct coupling with engine flywheel (in case of single bearing solution)
- neutral point terminals in separate terminal box
- dedicated current transformer installed on neutral point (differential protection and measurement)
- cooling system IC 616 with additional forced ventilation
- increase protection degree up to IP 56
- dedicated lubrication unit for sleeve bearing solution
- lifted feet to couple the generator with engine on existing baseframe
- redundant rotating rectifier with 12 diodes
- insulated bearing and earthing brush
- AVR supplied loose
- automatic power factor control (analog type or included into digital regulation)
- digital AVR MEC100 for frame 250 – 710 (supplied loose)
- digital AVR MEC100D with diode failure monitoring
- other digital AVR available on request.
- redundant AVR system
- excitation/overboosting PMG mounted generator
- arrangement for earthing rotor fault protection 64R
- other options available on request.

ODP generators: MJB



Model	MJB
Power	Up to 6.500 kVA
Voltages	Up to 1.000 V
Frame	160 ÷ 900
Pole	4, 6, 8, 10 and 12 (over contact MM)
Cooling	IC 01
IP	IP 23. Available up to IP 44 with filters.
Main applications	Power generation, auxiliary generators, emergency

	4 POLES	6 POLES	8 POLES	10 POLES	12 POLES
kVA	5.000	5.000	6.500	6.000	5.400

Certificates and testing

Applicable standards

Generators are designed in compliance with:
 IEC EN 60034 - 1
 BS 4999 - 5000
 VDE 0530
 NF 51 - 100
 NF 51 - 111
 OVE M - 10
 NEMA MG 1.32
 Generators conform to EU rules.
 UL/CSA certifications available on request.
 Adherence to ISO 8528 group G performance classes.

Test

See complete list on Test room chapter.

Main components

Housing

Rigid frame, rugged welded steel fabrication (EN 10025 - S235 JR).
 Frame is provided with side ribs to increase the strength.
 Marelli Generators for continuous duty operation are designed to meet vibration levels per IEC 60034-14, ISO 10816-1 and BS 5000-3.

Shield

Made of spheroidal graphite cast-iron (EN 1563) or grey cast-iron (EN 1561) up to 630 frame size.
 Made of structural steel (EN 10025 - S235 JR) above.

Shaft

General data

Made in carbon steel and obtained by lamination (EN 10083 - 2 C40 - TN). Shaft is obtained by forging from 290 mm diameter and above. The shaft is tested at the manufacturer in order to check it is defect-free.

Shaft design

Double bearing generator: cylindrical shaft with key.

Main terminal box Mounted on top up to 630 frame size.
Mounted on side from 710 frame size.
Made of formable steels EN 10130.

Fan Made of aluminum alloy (EN 1706) or structural steel (EN 10025-S235 JR) depending on application requirements.

Construction

Enclosure ODP - Open Drip Proof

Cooling system IC 01 as per IEC60034-6

Degree of protection IP 23 as per IEC60034-5. Available up to IP 44 with filters.

Mounting Horizontal - IM 1001 or IM 1101 as per IEC 60034-7.
Other mounting available on request.

Technical data

Stator/Rotor core Laminated and enamel-insulated on both sides to minimise eddy-current losses

Rotor Salient pole type.
Made by copper flat wire.
H class insulated with enamel coating.
Winding retaining by pass-through bars of high quality steel.
Rotating rectifier: Graetz diode bridge with 6 diodes.
Rotors are dynamically balanced with a half key applied to the shaft extension in accordance with IEC 60034-14 to vibration grade normal. A. Special vibration level construction are available.

Bearing **General data**
Single or double antifriction bearing grease lubricated (ball or roller type) or oil lubricated sleeve bearing.
The theoretical lifetime of bearings, L10h according to ISO 281/1 standard, of standard horizontal construction generators, without external forces (radial and / or axial) is in excess of 50.000 hours. On request, the lifetime of bearings, L10h can be in excess of 100.000 hours. Locating bearings are on the D end side and floating bearings on the ND end side.

Bearing selection

Antifriction bearings up to 800 frame size included. Sleeve bearings from 900 frame size included (available for smaller frame sizes).

Regreasing system:

Up to 250 frame size:

- D-end bearing is prelubricated with inner bearing cap and without grease nipple
- ND-end bearing is with shield (2Z) without regreasing system

315 - 355 frame size:

- D-end bearing is fitted with inner bearing cap and with grease nipple
- ND-end bearing is with shield (2Z) without regreasing system

400 frame size:

- D-end bearing is fitted with inner bearing cap and with grease nipple

- ND-end bearing is prelubricated with inner bearing cap and without grease nipple
- 450 frame size and above: both bearings are fitted with grease nipple.



Bearing insulation

ND end bearing can be insulated to prevent any harmful circulating current from passing through the bearing surfaces.

Insulated antifriction bearings in standard configuration:

- 4, 6 poles: insulated ND end bearing from 630 frame size
- 8 poles: insulated bearing from 400 frame size
- 10 poles: insulated bearing from 500 frame size

All ND end sleeve bearings are insulated as standard.

Impregnation system

Stator and rotor are VPI treated with an unsaturated polyester amide resin which is polymerised in an oven.

Insulation system

Stator: H class insulated with a synthetic enamel (class F available on request)
 Rotor: H class insulated with a synthetic enamel (class F available on request)

Protective treatments

Specific Oil&gas treatment.
 Epoxivinilic and polyacrylic. Total minimum thickness 120 micromillimeters.
 Epoxivinilic: Epoxy two component products, with vinyl change
 Polyacrylic: Two components polyurethane product formulated with unmodified hydroxyl acrylic resin.

Operating conditions

Overloads

During continuous duty (S1), the following overloads are allowed:
 10% for 1 hour
 15% for 10 minutes
 30% for 4 minutes
 50% for 2 minutes
 These overloads must be occasional and followed by one hour of running at normal load or less.

Parallel operations

All generators are provided with a amply sized damper cage and are suitable for parallel operations with other generators, when equipped with the paralleling unit. A power factor regulator (to work in parallel with the main) is available on request.

Transient performance

All generators can be designed to meet specific reactance values ($x'd$ and $x''d$). Values can be confirmed by contacting Marelli Motori.

Three phase short circuit current

All generators equipped with overboosting device ensure a three phase short circuit current (I_{cc}) higher than 3 times the rated current (I_n):
 $I_{cc} > 300\% I_n$

Radio interference

All generators are equipped with Class B Group 1 radio interference filters as defined by EN 55011.

THD (Total Harmonic Distortion)

The no-load voltage wave form is sinusoidal with THD content less than 2%.

Vibrations

Vibration level is in accordance with ISO 10816.
 Measurement, evaluation and limits of vibration severity are in accordance with IEC 60034-14.



Auxiliary devices

AVR Automatic voltage regulator mounted on board.

Size	Type
160 - 250	MARK V analog
315 - 450	MEC 20 analog/ digital
500 - 560	M40FA610A analog
630 - 710	M63FA310A analog
800 - 900	MEC 100 digital

Digital AVR available for all sizes on request.

Overboosting device

Size	Type
Low voltage	Auxiliary winding
160 - 450 (4 poles)	Varicomp
160 - 450 (>4 poles)	Varicomp
500 - 710 (all polarities)	Varicomp
800 - 900	PMG

PMG available for all sizes on request)

Space heaters

Heaters installed at ND end side.

Size	Power (W)
400 - 560	400
630 - 710	600
800 - 900	800

RTD - PT100

RTD devices in standard configuration:

- 1+1 RTD on each phase of stator winding
- 1 RTD on each bearing

Terminals in auxiliary terminal box.

Other configurations available:

- DUPLEX type
- RTD for inlet / outlet air

Optional features

- Flanged shaft for direct coupling with engine flywheel (in case of single bearing solution)
- neutral point terminals in separate terminal box
- dedicated current transformer installed on neutral point (differential protection and measurement)
- increase protection degree up to IP 44 with filters
- dedicated lubrication unit for sleeve bearing solution
- lifted feet to couple the generator with engine on existing baseframe
- redundant rotating rectifier with 12 diodes
- insulated bearing and earthing brush
- AVR supplied loose
- automatic power factor control (analog type or included into digital regulation)
- digital AVR MEC100 for frame 250 – 710 (supplied loose)
- digital AVR MEC100D with diode failure monitoring
- other digital AVR available on request.
- redundant AVR system
- excitation/overboosting PMG mounted generator
- arrangement for earthing rotor fault protection 64R
- other options available on request.



TEAAC generators: MJV



Model	MJV
Power	Up to 4.550 kVA
Voltages	Up to 1.000 V
Frame	250 ÷ 900
Pole	4, 6, 8, 10 and 12 (over contact MM)
Cooling	IC 611
IP	IP 55. Available up to IP 56
Main applications	Power generation, auxiliary generators and emergency

	4 POLES	6 POLES	8 POLES	10 POLES	12 POLES
kVA	3.500	4.550	4.550	4.550	4.000

Certificates and testing

Applicable standards

Generators are designed in compliance with:

IEC EN 60034 - 1

BS 4999 - 5000

VDE 0530

NF 51 - 100

NF 51 - 111

OVE M - 10

NEMA MG 1.32

Generators conform to EU rules.

UL/CSA certifications available on request.

Adherence to ISO 8528 group G performance classes.

Test

See complete list on Test room chapter.



Main components

Housing	Rigid frame, rugged welded steel fabrication (EN 10025 - S235 JR). Frame is provided with side ribs to increase strength. Marelli Generators for continuous duty operation are designed to meet vibration levels per IEC 60034-14, ISO 10816-1 and BS 5000-3.
.....	
Shield	Made of spheroidal graphite cast-iron (EN 1563) or grey cast-iron (EN 1561) up to 630 frame size. Made of structural steel (EN 10025 – S235 JR) above.
.....	
Shaft	General data Made in carbon steel and obtained by lamination (EN 10083 – 2 C40 – TN). Shaft is obtained by forging from 290 mm diameter and above. The shaft is tested by the manufacturer to ensure it is defect-free. Shaft design Double bearing generator: cylindrical shaft with key.
.....	
Main terminal box	Mounted on side (right or left will be selected). Made of formable steels EN 10130.
.....	
Fan	Made of aluminum alloy (EN 1706) or structural steel (EN 10025 – S235 JR) depending on application requirements.
.....	
Internal fan	Made of structural steel (EN 10025 - 5235 JR)
.....	
Heat Exchanger	Construction Mounted on top of alternator. Tube made of P - AlMgSi UNI 3569 Housing: EN 10025 - 5235JR

Construction

Enclosure	TEAAC – Totally Enclosed Air to Air Cooled
.....	
Cooling system	IC 611 as per IEC60034-6. Primary fluid (air) driven by a second fan (internal fan) mounted on shaft at ND end side. Internal air is flowing by a fan mounted on the shaft of the generator at the driven side.
.....	
Operating temperature	Up to 60° C ambient temperature (over contact Marelli Motori)
.....	
Degree of protection	IP 55 as per IEC60034-5. Other protection degree available on request.
.....	
Mounting	Horizontal - IM 1001 or IM 1101 as per IEC 60034-7. Other mounting available on request.

Technical data

Stator/Rotor core	Laminated and enamel-insulated on both sides to minimise eddy-current losses
.....	
Rotor	<p>Salient pole type. Made by copper flat wire. H class insulated with enamel coating. Winding retaining by pass-through bars of high quality steel. Rotating rectifier: Graetz diode bridge with 6 diodes. Rotors are dynamically balanced with a half key applied to the shaft extension in accordance with IEC 60034-14 to vibration grade normal A. Special vibration level construction are available.</p>
.....	
Bearing	<p>General data Single or double antifriction bearing grease lubricated (ball or roller type) or oil lubricated sleeve bearing. The theoretical lifetime of bearings, L10h according to ISO 281/1 standard, of standard horizontal construction generators, without external forces (radial and / or axial) is in excess of 50.000 hours. On request, the lifetime of bearings, L10h can be in excess of 100.000 hours. Locating bearings are on the D end side and floating bearings on the ND end side.</p> <p>Bearing selection Antifriction bearings up to 800 frame size included. Sleeve bearings from 900 frame size included (available for smaller frame sizes).</p> <p>Regreasing system: Up to 250 frame size:</p> <ul style="list-style-type: none"> • D-end bearing is prelubricated with inner bearing cap and without grease nipple • ND-end bearing is with shield (2Z) without regreasing system <p>315 - 355 frame size:</p> <ul style="list-style-type: none"> • D-end bearing is fitted with inner bearing cap and with grease nipple • ND-end bearing is with shield (2Z) without regreasing system <p>400 frame size:</p> <ul style="list-style-type: none"> • D-end bearing is fitted with inner bearing cap and with grease nipple • ND-end bearing is prelubricated with inner bearing cap and without grease nipple <p>450 frame size and above: both bearings are fitted with grease nipple.</p> <p>Bearing insulation ND end bearing can be insulated to prevent any harmful circulating current from passing through the bearing surfaces. Insulated antifriction bearings in standard configuration:</p> <ul style="list-style-type: none"> • 4, 6 poles: insulated ND end bearing from 630 frame size • 8 poles: insulated bearing from 400 frame size • 10 poles: insulated bearing from 500 frame size <p>All ND end sleeve bearings are insulated as standard.</p>
.....	
Impregnation system	Stator and rotor are VPI treated with an unsaturated polyester amide resin which is polymerised in an oven.
.....	
Insulation system	<p>Stator: H class insulated with a synthetic enamel (class F available on request) Rotor: H class insulated with a synthetic enamel (class F available on request)</p>
.....	
Protective treatments	<p>Specific Oil&gas treatment. Epoxivinilic and polyacrylic. Total minimum thickness 120 micromillimeters. Epoxivinilic: Epoxy two component products, with vinyl change Polyacrylic: Two components polyurethane product formulated with unmodified hydroxyl acrylic resin.</p>



Operating conditions

Overloads

During continuous duty (S1), the following overloads are allowed:

- 10% for 1 hour
- 15% for 10 minutes
- 30% for 4 minutes
- 50% for 2 minutes

These overloads must be occasional and followed by one hour of running at normal load or less.

Parallel operations

All generators are provided with a amply sized damper cage and are suitable for parallel operations with other generators, when equipped with the paralleling unit. A power factor regulator (to work in parallel with the main) is available on request.

Transient performance

All generators can be designed to meet specific reactance values ($x'd$ and $x''d$). Values can be confirmed by contacting Marelli Motori.

Three phase short circuit current

All generators equipped with overboosting device ensure a three phase short circuit current (I_{cc}) higher than three times the rated current (I_n):
 $I_{cc} > 300\% I_n$

Radio interference

All generators are equipped with Class B Group 1 radio interference filters as defined by EN 55011.

THD (Total Harmonic Distortion)

The no-load voltage wave form is sinusoidal with THD content less than 2%.

Vibrations

Vibration level is in accordance with ISO 10816.

Measurement, evaluation and limits of vibration severity are in accordance with IEC 60034-14.

Auxiliary devices

AVR

Automatic voltage regulator mounted on board.

Size	Type
250	MARK V analog
315 - 450	MEC 20 analog/ digital
500 - 560	M40FA610A analog
630 - 710	M63FA310A analog
800 - 900	MEC 100 digital

Digital AVR available for all sizes on request.

Overboosting device

	Size	Type
Low voltage	250 - 450 (4 poles)	Auxiliary winding
	400 - 450 (>4 poles)	Varicomp
	500 - 710 (all polarities)	Varicomp
	800 - 900	PMG

PMG available for all sizes on request)

Space heaters

Size	Power (W)
400 - 560	400
630 - 710	600
800 - 900	800

RTD - PT100

RTD devices in standard configuration:

- 1+1 RTD on each phase of stator winding
- 1 RTD on each bearing

Terminals in auxiliary terminal box.

Other configurations available:

- DUPLEX type
- RTD for inlet / outlet air
- RTD into oil tank for sleeve bearing

Optional features

- Flanged shaft for direct coupling with engine flywheel (in case of single bearing solution)
- neutral point terminals in separate terminal box
- dedicated current transformer installed on neutral point (differential protection and measurement)
- cooling system IC 616 with additional forced ventilation
- increase protection degree up to IP 56
- dedicated lubrication unit for sleeve bearing solution
- lifted feet to couple the generator with engine on existing baseframe
- redundant rotating rectifier with 12 diodes
- insulated bearing and earthing brush
- AVR supplied loose
- automatic power factor control (analog type or included into digital regulation)
- digital AVR MEC100 for frame 250 – 710 (supplied loose)
- digital AVR MEC100D with diode failure monitoring
- other digital AVR available on request.
- redundant AVR system
- excitation/overboosting PMG mounted generator
- arrangement for earthing rotor fault protection 64R
- other options available on request.



Testing facilities

Facilities	75
Routine and type test	75
Special testing	76

Facilities

Testing surface is 2.800 sqm. Load testing capacity up to 8 MW. Voltage range during test from 400 to 15.000 V. Test benches designed for testing machines up to 35 t in horizontal and vertical configuration.

Routine and type test

Routine test and type test are carried out in compliance with all major international standards (IEC60034, IEEE, UNI-EN-ISO, MIL-STD), IECX certificates, ATEX rules, UL certification and customer specifications.

Test for generators

Standard test < 500 frame (factory line)

- Name plate check
- voltage balance
- phase sequence
- no-load voltage regulation
- load test at power factor 0,1
- quadrature voltage drop test (test for parallel operation)
- low speed protection
- permanent short-circuit test with AVR
- winding insulation resistance test
- high voltage test.

Standard test ≥ 500 frame (test room)

- Name plate check
- winding resist. measurement at cold
- voltage balance
- phase sequence
- no-load voltage regulation
- load test at power factor 0,1
- quadrature voltage drop test (test for parallel operation)
- low speed protection
- permanent short-circuit test with AVR
- winding insulation resistance test
- high voltage test.

Routine test (standard test included)

- No load characteristic (magnetic curve)
- short circuit characteristics
- auxiliary check.

Type test (routine test included)

- Full load heat run test at power factor 0,1
- vibration
- over speed test
- heat run test.

Marine test (type test included)

- Waveform deviation and distortion test
- voltage response with sudden load change at power factor 0,1
- overload / overcurrent.

Test for motors

Standard test for motors

- Name plate check
- phase sequence
- winding insulation resistance test
- high voltage test
- no-load run test at nominal voltage.

Routine test for motors (standard test included)

- Winding resistance measurement at cold
- auxiliary check
- visual and dimensional check.

Type test for motors (routine test included)

- Full load heat run test at power factor 0,1
- vibration
- over speed test
- heat run test.

Special testing

Special tests for the measurement of mechanical and structural vibration and overspeed tests for high-voltage machines (dissipation factor and partial discharges).

We are able to process test on drive-motor systems in-house in order to ensure perfect compatibility to customer site conditions.

Special test for generators

- Determination of efficiency and losses
- sudden short-circuit test
- waveform deviation and distortion test
- measurement of noise level
- measurement of dissipation factor
- partial discharge test
- shaft voltage measurement
- visual and dimensional check
- voltage response with sudden load change at power factor 0,1
- overload / overcurrent
- IP test.

Special test for motors

- Measurement of noise level
- measurement of dissipation factor
- partial discharge test
- measurement of curve $C=f(n)$
- shaft voltage measurement
- visual and dimensional check.

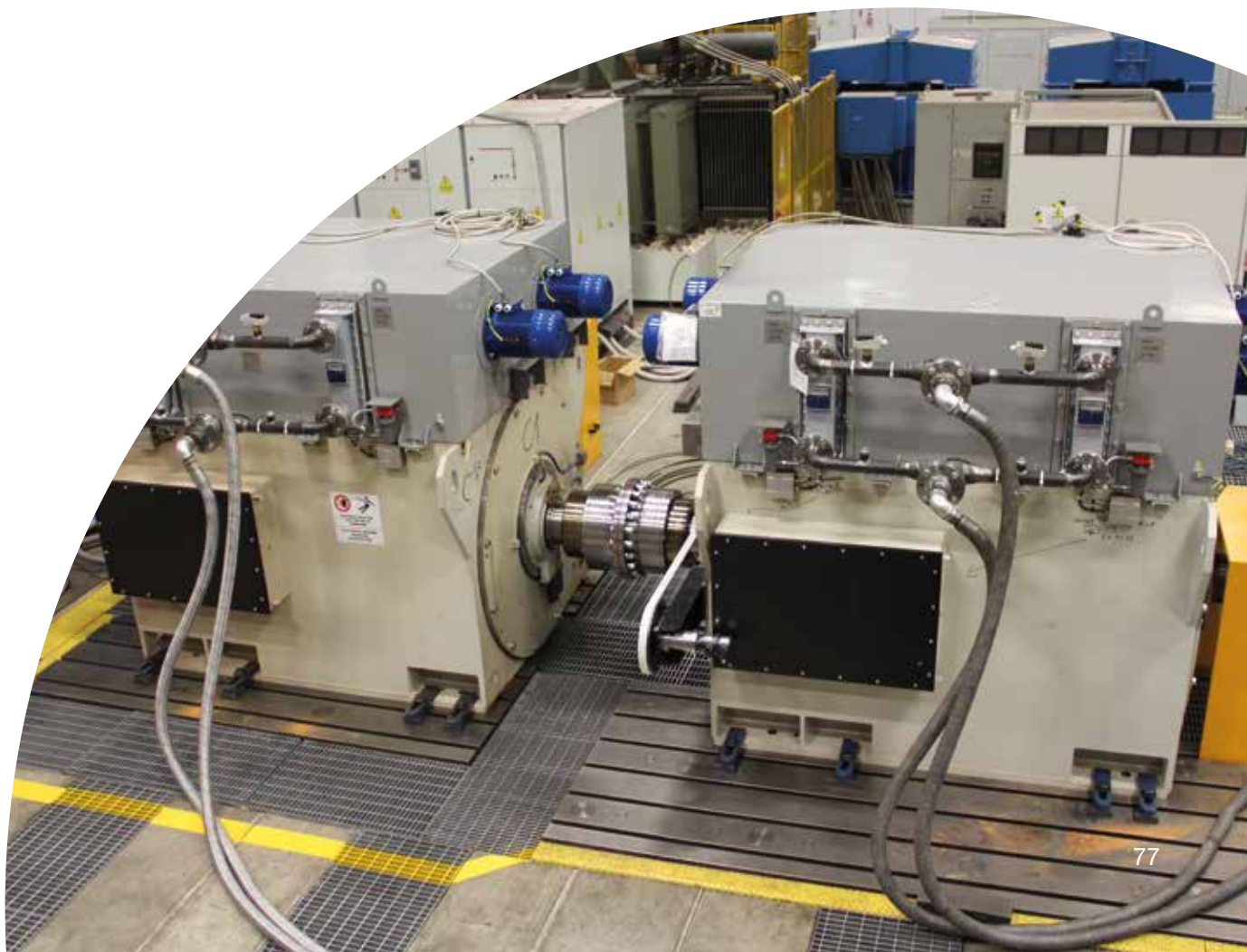



Services

Our service team	79
Aftersales services	79

Our Service team

Marelli Motori offers all-around support throughout the entire operational life of a product.

Our service team is committed to providing a fast, efficient and reliable service that keeps your motors and generators working productively, minimising downtime and lowering whole life costs.

We work closely with our manufacturing facilities to provide the highest levels of aftersales service worldwide, including commissioning, repairs, spare parts supply, technical support, performance enhancements, training courses and maintenance contracts of electrical machines of all makes.

Our service team offers technical advice to help improve performance, reduce operating costs, improve energy efficiency, minimising downtime and improve reliability.

We operate worldwide and are fully in compliance with the international quality rules, utilising highly skilled technicians and precision instruments to keep your machines working.

Aftersales services

Field service

Marelli Motori service personnel are trained to react quickly to any situation anywhere in the world. We rapidly analyse the source of machine problems and prescribe solutions which can get you 'up and running' quickly, minimising downtime and production losses.

We understand that, for a plant to operate efficiently, disruption must be kept to a minimum and that, when problems do occur, corrective action must be implemented quickly and effectively.

Marelli Motori Service is the solution to electrical machine problems, offering prompt technical support and ultra-fast response no matter where in the world you are located:

- diagnostic and functional tests
- start-up of brand-new machines
- revamping of regulation systems
- on the spot repairs
- custom-made maintenance programmes
- periodical inspections.

Commissioning

The Marelli Motori Commissioning Service includes all activities required for the efficient start-up of the machine during installation, to ensure maximum operational effectiveness from the start.

Our inspection processes during commissioning guarantee that the start-up phase takes place safely and that the correct functional parameters are applied.

The full commissioning option is available to buy with every machine purchase.

Repairs

Marelli Motori Service also offers repairs and complete refurbishing of motors and generators of any make or model.

Repairs of low, medium and high voltage machines can take place at the Marelli Motori manufacturing facility or at customer premises, delivered by our constantly expanding service network.

Our high tech facilities, which include computerised machine centres, VPI plants, 3D measurement systems, digital and infrared diagnostics tools, along with our long experience in designing and manufacturing machines, offer the highest quality of repairs and absolute reliability.

All repairs and testing take place in our modern test room that can handle machines up to 5 MW and a 13.8 kV before issuing functional test certificates and detailed repair reports.

Marelli Motori Service overhauls and tests any rotating electrical machine, including third party machines.

The characteristics of the overhaul procedure are:

- manufacturer know-how
- guarantee on the reparation
- original parts used
- tests in the internal testing room
- reports and about the reparations.

In addition Marelli Motori keeps an available stock of machines with common configurations, which can be supplied to customers for temporary use whilst their own machines are overhauled.

Spare parts

Genuine Marelli Motori spare parts are available at the Marelli headquarters, branch offices, and service centres located all over the world, with specific characteristics:

- original and guaranteed parts.
- branded package.
- major equipment assemblies (complete rotors, stators).
- kits of recommended spare parts.
- spare stocks on Marelli Motori branches.

This policy covers all spare parts manufactured by Marelli Motori.

In the event that a component is out-of-production, Marelli Motori Spa will source and propose the suitable interchangeable spare parts. All spare parts are certified by Marelli Motori Spa for the operating conditions proposed.

Technical support

Marelli Motori customers can access our outstanding technical support at all times to ensure their machines are safety, reliable and productive.

Our service engineers and technicians, from headquarter or subsidiaries, are always at our customer's disposal to assist in solving technical issues by either phone or email.

Training

Training courses are available all year round to users and maintenance personnel to ensure the correct operation and maintenance of machines.

Our customised training sections are tailor-made for:

- customers
- users
- operators for the selection operation and maintenance of electrical equipment.

Training courses

Our training courses include:

- electrical generator working principle and troubleshooting
- electric generator setting and maintenance
- digital voltage regulation with MEC100.
- ATEX directive for maintenance of hazardous area motors.

In addition to the training in this brochure, it is possible to specify customised training based on a customer's own requirements. Training language is either in Italian or English. At the end of each course, each participant will receive a personalised certificate, based on the result of a final test.

Contacts

Italy HQ

Marelli Motori S.p.A.
Via Sabbionara 1
36071 Arzignano (VI)
Italy
(T) +39 0444 479 711
(F) +39 0444 479 888
info@MarelliMotori.com
sales@MarelliMotori.com

Asia Pacific

Marelli Motori Asia Sdn Bhd
Lot 1-8, Persiaran Jubli Perak,
Seksyen 22, 40300 Shah Alam,
Selangor D.E.
Malaysia
(T) +60 355 171 999
(F) +60 355 171 883
Malaysia@MarelliMotori.com
sales.MY@MarelliMotori.com

Central Europe

Marelli Motori Central Europe GmbH
Heilswannenweg 50
31008 Elze
Germany
(T) +49 5068 462 400
(F) +49 5068 462 409
Germany@MarelliMotori.com
sales.DE@MarelliMotori.com

Middle East

Marelli Motori Middle East
4403-18, 44th Floor, BB2
Mazaya Business Avenue
Jumeirah Lakes Towers
Dubai - UAE
(T) +971 4 426 4263
(F) +971 4 362 4345
UAE@MarelliMotori.com
sales.UAE@MarelliMotori.com

South Africa

Marelli Motori South Africa (Pty) Ltd
Unit 2, corner Director & Megawatt Road
Spartan Ext. 23
Kempton Park 1619 Gauteng
Republic of South Africa
(T) +27 11 392 1920
(F) +27 11 392 1668
SouthAfrica@MarelliMotori.com
sales.ZA@MarelliMotori.com

Spain

08195 Sant Cugat
Barcelona
Spain
(T) +34 664 464 121
Spain@MarelliMotori.com

United Kingdom

Marelli UK
Main Street, The Old Rectory
Glenfield
Leicester LE3 8DG
United Kingdom
(T) +44 116 232 5167
(F) +44 116 232 5193
UK@MarelliMotori.com
sales.UK@MarelliMotori.com

USA

Marelli USA, Inc.
2200 Norcross Parkway, Suite 290
Norcross, GA 30071
USA
(T) +1 859 734 2588
(F) +1 859 734 0629
USA@MarelliMotori.com
sales.USA@MarelliMotori.com